

Document No.	853-1436
ECN No.	99799
Date of Issue	June 14, 1990
Status	Product Specification
ECL Products	

10129

Line Receiver

Quad TTL-to-ECL Translator

FEATURES

- Typical propagation delay: 10.0ns
- Typical TTL supply current (I_{CC}): 3.0mA
- Typical ECL supply current ($-I_{EE}$): 144mA

DESCRIPTION

The 10129 is intended to allow interfacing of 10K family types with other logic devices or systems. The enable, reset and strobe inputs are compatible with 10K family logic levels whereas data inputs accept TTL logic levels compatible with IBM-type busses. The information received from the bus is stored temporarily in latch storage elements.

The strobe input is useful to provide accurate synchronization of signals and/or connection to 10K family type level busses. When the enable is Low, the reset input is disabled and the outputs will follow the data inputs. The latches store data when the enable goes High. Unused data inputs must be tied to V_{CC} or ground. On the other hand, enable, strobe and reset inputs must be tied to V_{IL} or V_{EE} if unused.

The outputs are enabled when the strobe input is High. Two modes of operation are provided. In the first mode, obtained by tying the hysteresis control input to V_{EE} , the input threshold points of the D inputs are fixed. In the second mode this hysteresis control input is connected to ground which gives an hysteresis input effect useful for increasing the D input noise margin.

ORDERING INFORMATION

DESCRIPTION	ORDER CODE
16-Pin Plastic DIP	10129N
16-Pin Ceramic DIP	10129F

PIN DESCRIPTION

PINS	DESCRIPTION
$D_0 - D_3$	Data Inputs
H	Hysteresis control Input
E	Enable Input
R	Reset Input
ST	Strobe input
$Q_1 - Q_3$	Data Outputs

PIN CONFIGURATION

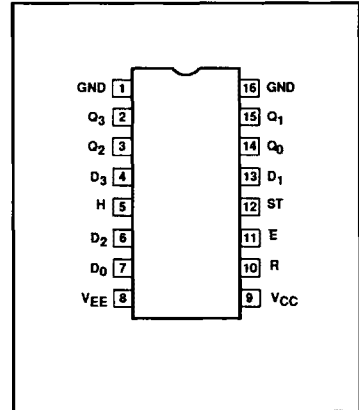

LOGIC DIAGRAM

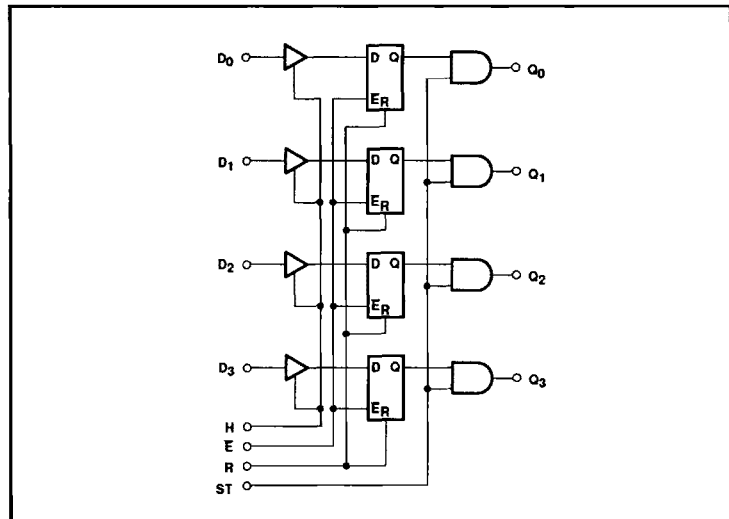

Line Receiver

10129

FUNCTION TABLE

INPUTS				OUTPUT
D _n	E	ST	R	Q _{n+1}
X	X	L	X	L
X	H	X	H	L
L	L	H	X	H
X	H	H	L	Q _n
H	L	H	X	H

H = High voltage level
 L = Low voltage level
 X = Don't care

ABSOLUTE MAXIMUM RATINGS FOR ECL-COMPATIBLE LINES

SYMBOL	PARAMETER	LIMIT	UNIT
V _{EE}	Supply voltage	-8.0	V
V _{IN}	Input voltage (V _{IN} should never be more negative than V _{EE})	0 to V _{EE}	V
I _O	Output source current (continuous)	-50	mA
T _S	Storage temperature range	-55 to +150	°C
T _J	Maximum junction temperature	Ceramic Package	+165
		Plastic Package	+150

NOTE:
 Operation beyond the limits set forth in this table may impair the useful life of the device. Unless otherwise noted, these limits are specified over the operating ambient temperature range.

ABSOLUTE MAXIMUM RATINGS FOR TTL-COMPATIBLE LINES

SYMBOL	PARAMETER	LIMIT	UNIT
V _{CC}	TTL supply voltage	-5.0 to +7.0	V
V _{IN}	Input voltage	-0.5 to V _{TTL}	V
I _{IN}	Input current	-30 to +5	mA

NOTE:
 Operation beyond the limits set forth in this table may impair the useful life of the device. Unless otherwise noted, these limits are specified over the operating ambient temperature range.

DC OPERATING CONDITIONS FOR ALL INPUT LEVELS

SYMBOL	PARAMETER	LIMITS			UNIT
		MIN.	NOM.	MAX.	
GND	Circuit ground	0	0	0	V
V _{EE}	ECL supply voltage		-5.2		V
V _{CC}	TTL supply voltage		+5.0		V
T _A	Operating ambient temperature range	-30	+25	+85	°C

NOTE:
 When operating at V_{EE} other than specified voltage (-5.2V), the DC and AC Characteristics will vary slightly from specified values. (See table of DC Characteristics.)

Line Receiver

10129

DC OPERATING CONDITIONS FOR ECL INPUT LEVELS

SYMBOL	PARAMETER	TEST CONDITION	LIMITS			UNIT
			MIN.	NOM.	MAX.	
V_{IH}	High level input voltage	$T_A = -30^\circ\text{C}$			-890	mV
		$T_A = +25^\circ\text{C}$			-810	mV
		$T_A = +85^\circ\text{C}$			-700	mV
V_{IHT}	High level input threshold voltage	$T_A = -30^\circ\text{C}$	-1205			mV
		$T_A = +25^\circ\text{C}$	-1105			mV
		$T_A = +85^\circ\text{C}$	-1035			mV
V_{ILT}	Low level input threshold voltage	$T_A = -30^\circ\text{C}$			-1500	mV
		$T_A = +25^\circ\text{C}$			-1475	mV
		$T_A = +85^\circ\text{C}$			-1440	mV
V_{IL}	Low level input voltage	$T_A = -30^\circ\text{C}$	-1890			mV
		$T_A = +25^\circ\text{C}$	-1850			mV
		$T_A = +85^\circ\text{C}$	-1825			mV

DC OPERATING CONDITIONS FOR TTL INPUT LEVELS

SYMBOL	PARAMETER	TEST CONDITION	LIMITS			UNIT
			MIN.	NOM.	MAX.	
V_{IH}	High level input voltage	$T_A = -30^\circ\text{C}$	3.000			V
		$T_A = +25^\circ\text{C}$	3.000			V
		$T_A = +85^\circ\text{C}$	3.000			V
V_{IHT}'	High level input threshold voltage	$T_A = -30^\circ\text{C}$	2.000			V
		$T_A = +25^\circ\text{C}$	2.000			V
		$T_A = +85^\circ\text{C}$	2.000			V
V_{ILT}'	Low level input threshold voltage	$T_A = -30^\circ\text{C}$			0.800	V
		$T_A = +25^\circ\text{C}$			0.800	V
		$T_A = +85^\circ\text{C}$			0.800	V
V_{IL}	Low level input voltage	$T_A = -30^\circ\text{C}$			0.400	V
		$T_A = +25^\circ\text{C}$			0.400	V
		$T_A = +85^\circ\text{C}$			0.400	V

Line Receiver

10129

DC OPERATING CONDITIONS FOR IBM INPUT LEVELS

SYMBOL	PARAMETER	TEST CONDITION	LIMITS			UNIT
			MIN.	NOM.	MAX.	
V _{IH}	High level input voltage	T _A = -30°C	3.110			V
		T _A = +25°C	3.110			V
		T _A = +85°C	3.110			V
V _{IHT}	High level input threshold voltage	T _A = -30°C				V
		T _A = +25°C	1.700			V
		T _A = +85°C				V
V _{ILT}	Low level input threshold voltage	T _A = -30°C				V
		T _A = +25°C			0.700	V
		T _A = +85°C				V
V _{IL}	Low level input voltage	T _A = -30°C			0.150	V
		T _A = +25°C			0.150	V
		T _A = +85°C			0.150	V

DC OPERATING CONDITIONS FOR HYSTERESIS MODE THRESHOLD VOLTAGES

SYMBOL	PARAMETER	TEST CONDITION	LIMITS			UNIT
			MIN.	NOM.	MAX.	
V _{IHT} "	Hysteresis mode High level input threshold voltage	T _A = -30°C	2.900			V
		T _A = +25°C	2.600			V
		T _A = +85°C	2.300			V
V _{ILT} "	Hysteresis mode Low level input threshold voltage	T _A = -30°C			2.000	V
		T _A = +25°C			1.700	V
		T _A = +85°C			1.400	V
V _{IHT} '''	Hysteresis mode High level input threshold voltage	T _A = -30°C	2.200			V
		T _A = +25°C	1.900			V
		T _A = +85°C	1.600			V
V _{ILT} '''	Hysteresis mode Low level input threshold voltage	T _A = -30°C			1.300	V
		T _A = +25°C			1.000	V
		T _A = +85°C			0.700	V

NOTE:

V_{IHT}", V_{IL}", V_{IHT}''' and V_{IL}''' are logic "1" and "0" threshold voltages in the hysteresis mode.

HYSTERSIS MODE THRESHOLD VOLTAGES

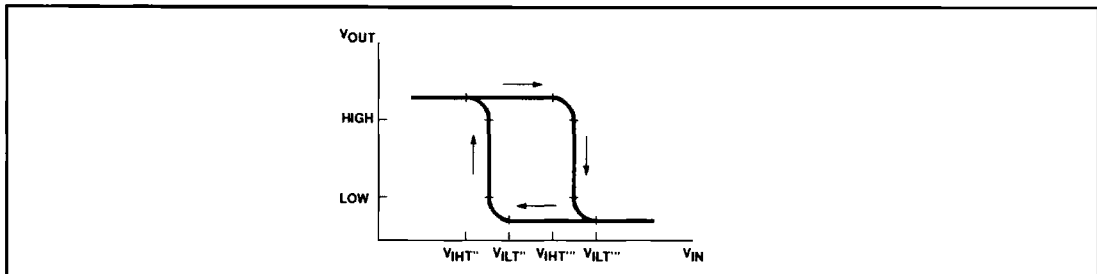

Line Receiver

10129

DC ELECTRICAL CHARACTERISTICS GND = ground, $V_{EE} = -5.2V \pm 0.010V$, $V_{CC} = +5.0V \pm 0.010V$, $T_A = -30^\circ C$ to $+85^\circ C$ output loading 50Ω to $-2.0V \pm 0.010V$ unless otherwise specified^{1,3}

SYMBOL	PARAMETER	TEST CONDITIONS ²	LIMITS			UNIT	
			MIN.	TYP.	MAX.		
V _{OH}	High level output voltage	T _A = -30°C	-1060		-890	mV	
		T _A = +25°C	-960		-810	mV	
		T _A = +85°C	-890		-700	mV	
V _{OHT}	High level output threshold voltage	T _A = -30°C	-1080			mV	
		T _A = +25°C	-980			mV	
		T _A = +85°C	-910			mV	
V _{OLT}	Low level output threshold voltage	T _A = -30°C			-1655	mV	
		T _A = +25°C			-1630	mV	
		T _A = +85°C			-1595	mV	
V _{OL}	Low level output voltage	T _A = -30°C	-1890		-1675	mV	
		T _A = +25°C	-1850		-1650	mV	
		T _A = +85°C	-1825		-1615	mV	
I _{IH}	High level input current	D _n inputs	T _A = -30°C			150	μA
			T _A = +25°C			95	μA
			T _A = +85°C			95	μA
		R input	T _A = -30°C			720	μA
			T _A = +25°C			450	μA
			T _A = +85°C			450	μA
		E, ST inputs	T _A = -30°C			390	μA
			T _A = +25°C			245	μA
			T _A = +85°C			245	μA
-I _{CBO}	Input leakage current	D _n inputs	T _A = -30°C			1.5	μA
			T _A = +25°C			1.0	μA
			T _A = +85°C			1.0	μA
I _{IL}	Low level input current	R, E, ST inputs	T _A = -30°C	0.5		μA	
			T _A = +25°C	0.5		μA	
			T _A = +85°C	0.3		μA	

Line Receiver

10129

DC ELECTRICAL CHARACTERISTICS (Continued)

SYMBOL	PARAMETER	TEST CONDITIONS ²		LIMITS			UNIT
				MIN.	TYP.	MAX.	
-I _{EE}	ECL supply current	T _A = -30°C	Connect H to GND ST = V _{IHMIN} , E = V _{ILMIN}			167	mA
		T _A = +25°C				152	mA
		T _A = +85°C				167	mA
		T _A = -30°C	Apply V _{EE} to H ST = V _{IHMIN} , E = V _{ILMIN}			189	mA
		T _A = +25°C				172	mA
		T _A = +85°C				189	mA
I _{CC}	TTL supply current	T _A = -30°C	Apply V _{EE} to H			8.0	mA
		T _A = +25°C				8.0	mA
		T _A = +85°C				8.0	mA
$\frac{\Delta V_{OH}}{\Delta V_{EE}}$	High level output voltage compensation	T _A = +25°C			0.016		V/V
$\frac{\Delta V_{OL}}{\Delta V_{EE}}$	Low level output voltage compensation				0.250		V/V
$\frac{\Delta V_{BB}}{\Delta V_{EE}}$	Reference bias voltage compensation				0.148		V/V

NOTES:

- The specified limits represent the worst case values for the parameter. Since these worst case values normally occur at the supply voltage and temperature extremes, additional noise immunity can be achieved by decreasing the allowable operating condition ranges.
- Conditions for testing shown in the tables are not necessarily worst case. For worst case testing guidelines, refer to DC Testing, Chapter 1, Section 3.
- The specified limits shown in the DC Electrical Characteristics table can be met only after thermal equilibrium has been established. Thermal equilibrium is established by applying power for at least 2 minutes, while maintaining transverse airflow of 2.5 meters/sec (500 linear feet/min) over the device, mounted either in a test socket or on a printed circuit board. Test voltage values are given in the DC Operating Conditions table.

AC ELECTRICAL CHARACTERISTICS GND = ground, V_{EE} = -5.2V ± 0.010V, V_{CC} = +5.0V ± 0.010V

SYMBOL	PARAMETER	TEST CONDITIONS	LIMITS							UNIT
			T _A = -30°C		T _A = +25°C			T _A = +85°C		
			MIN.	MAX.	MIN.	TYP.	MAX.	MIN.	MAX.	
t _{PLH} t _{PHL}	Propagation delay without Hysteresis, D _n to Q _n	Connect H to V _{EE} , Waveform 1	3.7 3.7	15 15	3.7 3.7	10.0 10.0	15 15	3.7 3.7	30 40	ns ns
t _{PLH} t _{PHL}	Propagation delay with Hysteresis, D _n to Q _n	Connect H to GND, Waveform 1	6.6 3.7	30 17	6.7 3.7	18.0 10.0	25 15	6.6 3.7	30 40	ns ns
t _{PLH} t _{PHL}	Propagation delay E to Q _n	Waveforms 2, 4	2.7 2.7	11 11	2.7 2.7	5.0 5.0	9.0 9.0	2.7 2.7	11 11	ns ns
t _{PLH} t _{PHL}	Propagation delay ST to Q _n	Waveform 3	1.6 1.6	8.0 8.0	1.6 1.6	4.0 4.0	7.0 7.0	1.6 1.6	8.0 8.0	ns ns
t _{PLH} t _{PHL}	Propagation delay R to Q _n	Waveform 4	2.0 2.0	8.0 8.0	2.0 2.0	5.0 5.0	6.5 6.5	2.0 2.0	8.0 8.0	ns ns
t _s	Setup time D _n to E	Waveform 5	30		2.7	15.0		30		ns
t _h	Hold time D _n to E	Waveform 5	0		-2.0	15.0		-2.0		ns
t _{TLH} t _{THL}	Transition time 20% to 80%, 80% to 20%	Waveforms 1, 2, 3, 4	1.5 1.5	5.0 5.0	1.5 1.5	2.0 2.0	4.3 4.3	1.5 1.5	5.0 5.0	ns ns

NOTE:

For AC test setup information, see AC Testing, Chapter 2, Section 3.

Line Receiver

10129

AC WAVEFORMS

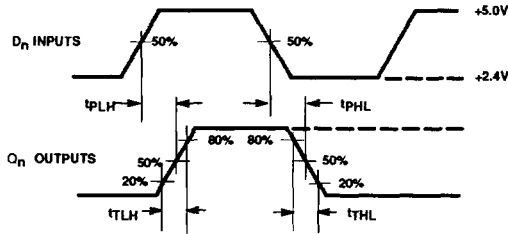

Waveform 1. D_n Timing (E and R are Low, ST is High)

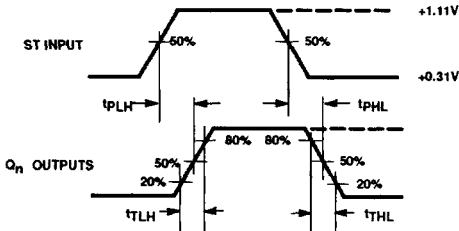

Waveform 2. D_n Timing (R is Low, ST is High)

Waveform 3. Strobe Timing (E and R are Low, D_n is High)

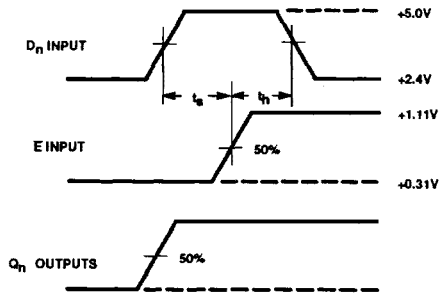

Waveform 5. Setup and Hold Times

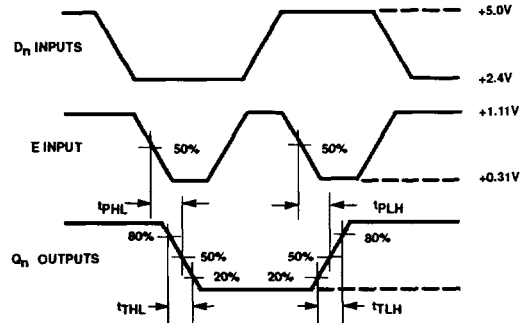

Waveform 4. Reset Timing (D_n and ST are High)

Line Receiver

10129

AC TEST CIRCUIT

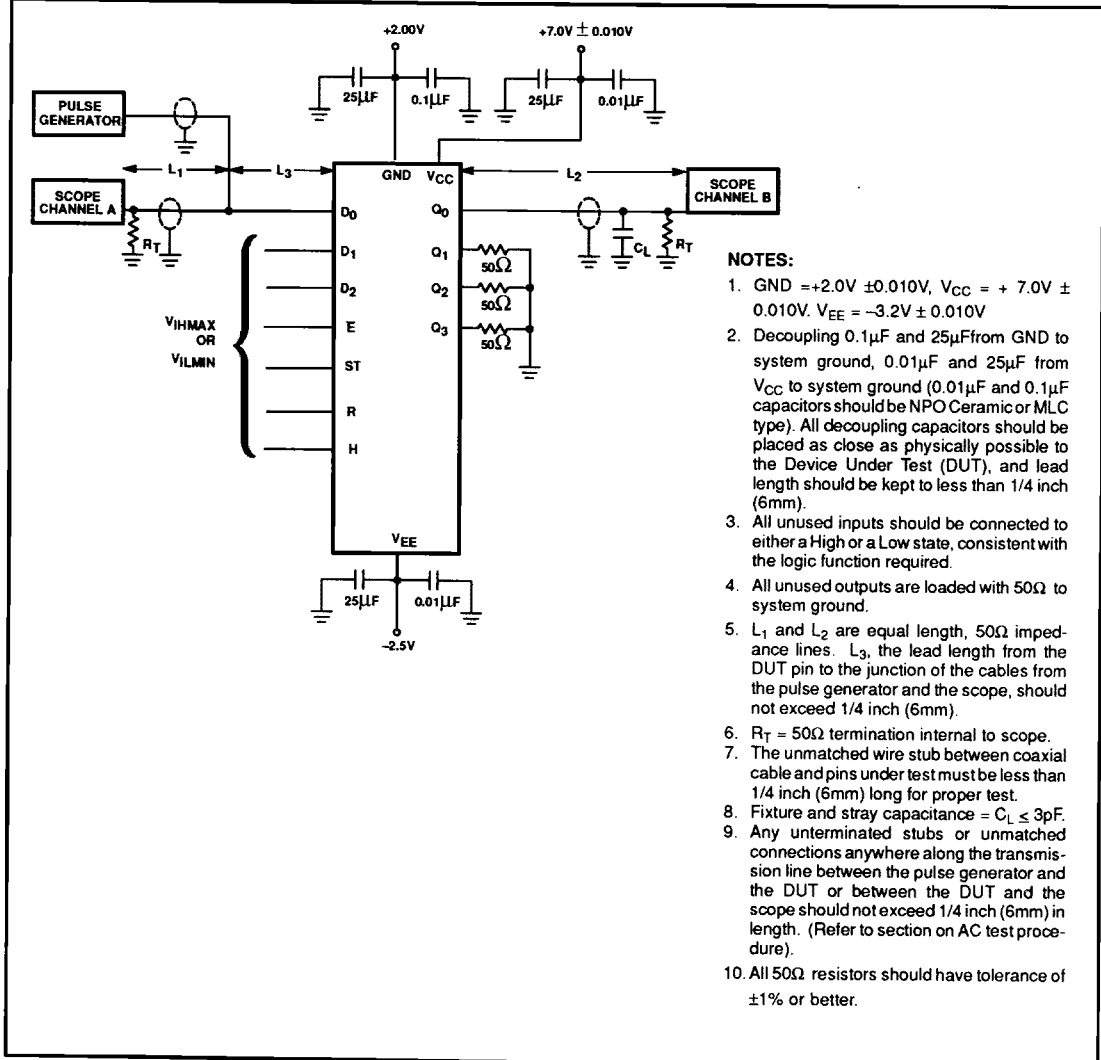

Line Receiver

10129

ECL INPUT PULSE DEFINITION

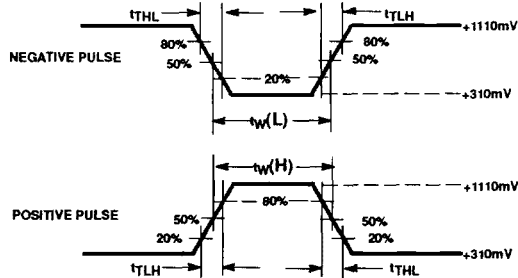

INPUT PULSE REQUIREMENTS					
GND = +2.0V ± 0.010V, V _{CC} = +7.0V ± 0.010V, V _{EE} = -3.2V ± 0.010V, V _T = 0V (system ground)					
Family	Amplitude	Rep Rate	t _w (H), t _w (L)	t _{TLH}	t _{THL}
10K ECL	800mV _{p-p}	1MHz	500ns	2.0 ± 0.2ns	2.0 ± 0.2ns

TTL INPUT PULSE DEFINITION

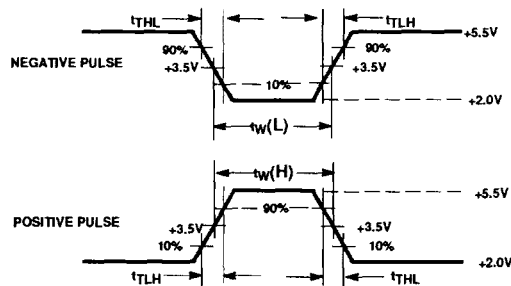

INPUT PULSE REQUIREMENTS					
GND = +2.0V ± 0.010V, V _{CC} = +7.0V ± 0.010V, V _{EE} = -3.2V ± 0.010V, V _T = 0V (system ground)					
Family	Amplitude	Rep Rate	t _w (H), t _w (L)	t _{TLH}	t _{THL}
TTL	3.0V _{p-p}	1MHz	500ns	2.5 ± 0.2ns	2.5 ± 0.2ns