

FEATURES AND SPECIFICATIONS

Features and Benefits

- Wire-to-board vertical header with mounting pegs for increased retention
- Positive housing locks
- Fully isolated terminals
- Contrasting color (white) TPA/CPA for high visibility
- Redundant housing lock (CPA)

Reference Information

Product Specification: PS-5556-0003
 Packaging: Tray and bag
 UL File No.: E29179
 CSA File No.: LR19980
 TUV License No.: R75142
 Use With: Standard Mini-Fit terminals
 Mates With: [30067](#) receptacle
 Designed In: Millimeters

Electrical

Voltage: 600V
 Current: (Used with 16 AWG)

Circuits	2-3	4-6	7-10	12-24
Amperes-TPA	9	8	7	6

Contact Resistance: 10mΩ max.
 Dielectric Withstanding Voltage: 1500V
 Insulation Resistance: 1000 MΩ min.

Mechanical

Insertion Force to PCB: 5.0kg max.
 Mating Force: 0.7kg (1.54 lb) max.
 Unmating Force: 0.35kg (0.7 lb) min.
 Normal Force: 200g min.
 Durability: 30 cycles

Physical

Housing: Black polyester, UL 94V-0
 Contact: Brass or Phosphor Bronze
 Plating: Tin, select Gold and overall Gold
 Operating Temperature: -40 to +105°C



4.20mm (.165") Pitch Mini-Fit, TPA™ Header

30069

Vertical, Dual Row With Pegs

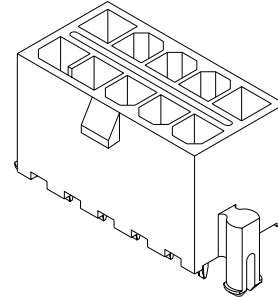

CATALOG DRAWING (FOR REFERENCE ONLY)

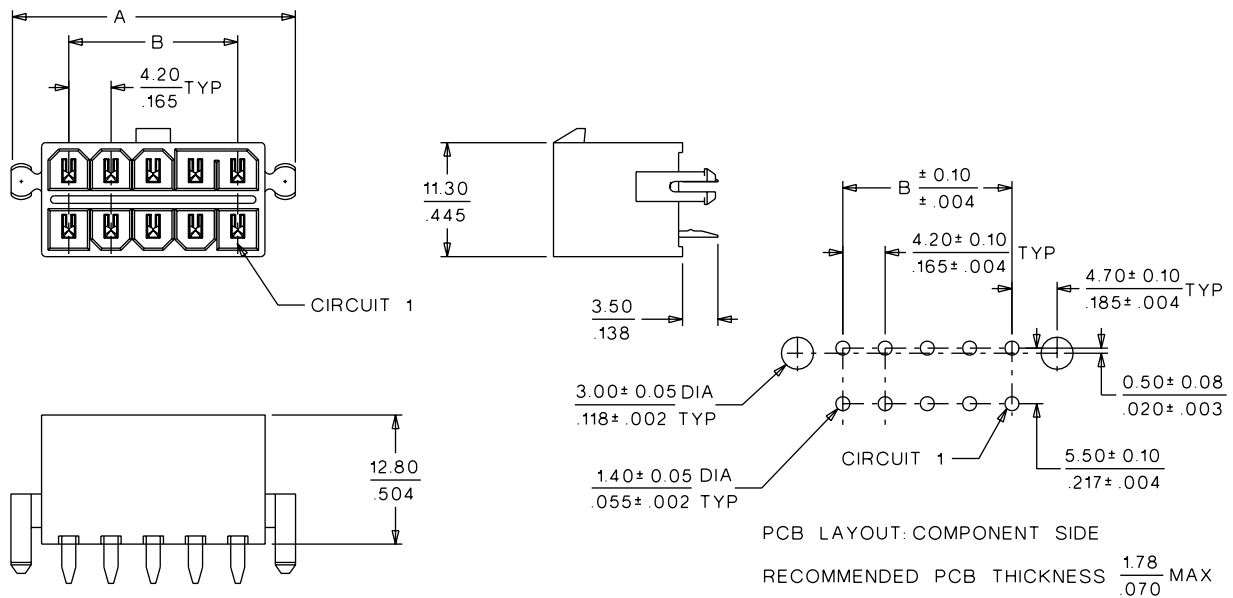

ORDERING INFORMATION AND DIMENSIONS

Circuits	With Drain Holes		Dimension	
	Order No.		A	B
	Tin Plated	Gold Plated		
2			5.40 (.213)	
4			9.60 (.378)	4.20 (.165)
6	• 15-97-7067	• 15-97-7069	13.80 (.543)	8.40 (.331)
8			18.00 (.709)	12.60 (.496)
10			22.20 (.874)	16.80 (.661)
12			26.40 (1.039)	21.00 (.827)
14			30.60 (1.205)	25.20 (.992)
16			34.80 (1.370)	29.40 (1.157)

Circuits	Without Drain Holes		Dimension	
	Order No.		A	B
	Tin Plated	Gold Plated		
2			5.40 (.213)	
4			9.60 (.378)	4.20 (.165)
6	• 15-97-7063	• 15-97-7065	13.80 (.543)	8.40 (.331)
8			18.00 (.709)	12.60 (.496)
10			22.20 (.874)	16.80 (.661)
12			26.40 (1.039)	21.00 (.827)
14			30.60 (1.205)	25.20 (.992)
16			34.80 (1.370)	29.40 (1.157)

• US Standard Product, available through Molex franchised distributors

NOTES:

1. HOUSING MAT'L.: POLYESTER, UNFILLED, 94V-0. COLOR: BLACK.
2. TERMINAL MATERIAL: BRASS ALLOY 260.
3. PART MATES WITH RECEPTACLE 30067-*..
4. PRODUCT SPECIFICATION: PS-5556-003
5. PART IS DESIGNED FOR USE WITH 4-40 OR M3 SCREWS.
6. PLATINGS:
 - 1 = .000035/(.00090) MIN. TIN OVER .000020/(.00050) MIN. COPPER.
 - 2 = .000030/(.00076) MIN. SELECT GOLD AND .000100/(.00254) MIN. SELECT TIN OVER .000050/(.00127) MIN. NICKEL.

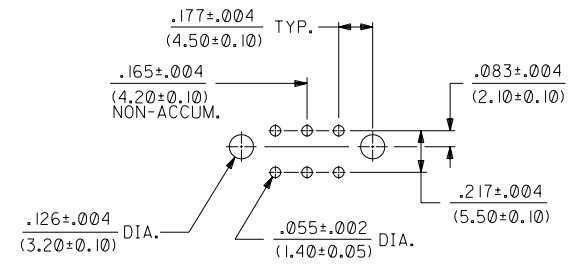
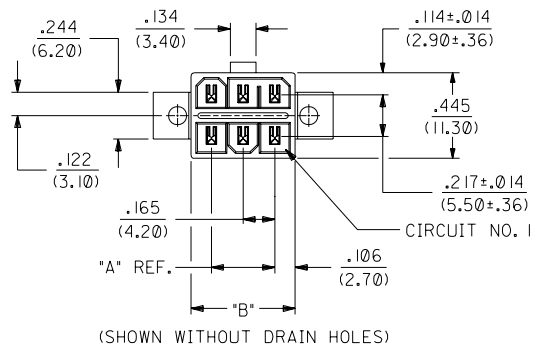
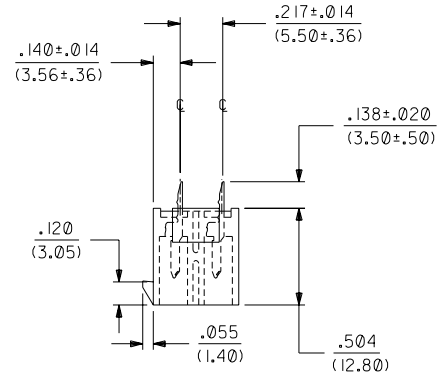
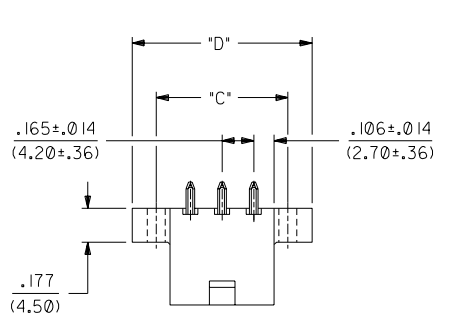

RECOMMENDED HOLE LAYOUT FOR
.070/(1.78) MAX. THICK P.C. BOARD

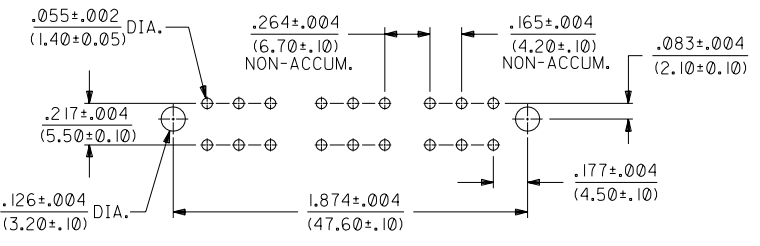

18 CIRCUIT

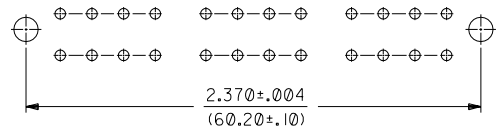

24 CIRCUIT

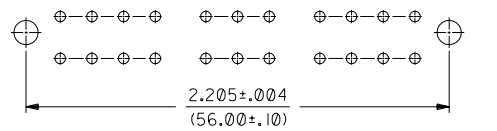

22 CIRCUIT

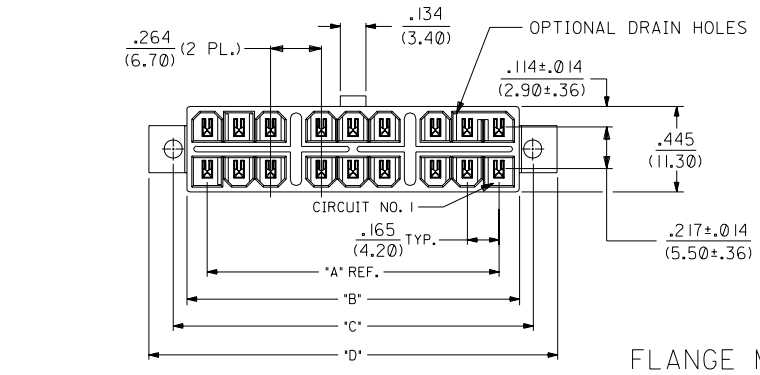

FLANGE MOUNT

(SEE SHT. 2 FOR PARTS WITH PEGS)

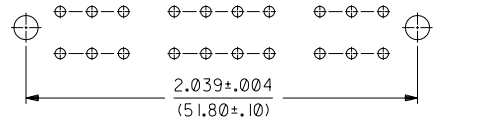

20 CIRCUIT

F	REV. PS NOTE UCF2003-0367 8/30/2002 SAMIEC
E	ADDED EDP'S PER ECN #U3-1590 93-10-27 A.GUZIK
D3	REMOVED PLAIN ECN U30726 GEP 5-14-93
D2	ADDED EDP'S PER ECR U21586 10-28-92 RJF
D1	REV. PER ECN U21270 8-26-92 RJF
D	REV. PER ECN U21043 GEP 7-14-92 RJF
C1	ADDED E.D.P.'S ECN U20701 GEP 5-1-92 RJF
C	MAT'L WAS NYLON ECN U20072 GEP 4-3-92 RJF
4	E B ADDED SHT 5 ECN U20057 GEP 1-22-92 RJF
3	E B
2	D3 A REVISED & REDRAWN ECN U11897 9-24-91 RJF
1	F A

DIMENSIONS SHOWN (METRIC) INCH UNLESS OTHERWISE SPECIFIED TOLERANCES: ANGULAR ± 1/2°		▽ = 0		REVISION ONLY ON CAD SYSTEM	
3 PLACE ± .010		INCH		METRIC	
2 PLACE ± .014		---		---	
1 PLACE ---		± 0.25		± 0.36	
DRAFT WHERE APPLICABLE MUST REMAIN WITHIN DIMENSIONS					
DRWG. BY: RJF	CHK'D. BY: GEP	APP'D. BY: RAS	SCALE: 2:1	FILE NAME: S30069X1.DGN	TITLE: MINI-FIT T.P.A. VERTICAL HEADER ASSEMBLY
SEE CHARTS			SDA-30069-****		
PART NO. MOLEX INCORPORATED LISLE, ILL. 60532		SHEET NO. 1 OF 4		DATE 9/19/91	
THIS DRAWING CONTAINS INFORMATION THAT IS PROPRIETARY TO MOLEX INC. AND SHOULD NOT BE USED WITHOUT WRITTEN PERMISSION.					

TIN-PLATED ASSEMBLIES WITH PEGS, WITHOUT DRAIN HOLES.							GOLD-PLATED ASSEMBLIES WITH PEGS, WITHOUT DRAIN HOLES.						
CKT. SIZE	ENG. NO.	EDP. NO.	DIM. 'A'	DIM. 'B'	DIM. 'C'	DIM. 'D'	CKT. SIZE	ENG. NO.	EDP. NO.	DIM. 'A'	DIM. 'B'	DIM. 'C'	DIM. 'D'
2	A-30069-02C1	NOT TOOLED	—	.213 (5.40)	.370 (9.40)	—	2	A-30069-02C2	NOT TOOLED	—	.213 (5.40)	.370 (9.40)	—
4	A-30069-04C1	NOT TOOLED	.165 (4.20)	.378 (9.60)	.535 (13.60)	—	4	A-30069-04C2	NOT TOOLED	.165 (4.20)	.378 (9.60)	.535 (13.60)	—
6	A-30069-06C1	15-97-7063	.331 (8.40)	.543 (13.80)	.701 (17.80)	—	6	A-30069-06C2	15-97-7065	.331 (8.40)	.543 (13.80)	.701 (17.80)	—
8	A-30069-08C1	NOT TOOLED	.496 (12.60)	.709 (18.00)	.866 (22.00)	—	8	A-30069-08C2	NOT TOOLED	.496 (12.60)	.709 (18.00)	.866 (22.00)	—
10	A-30069-10C1	NOT TOOLED	.661 (16.80)	.874 (22.20)	1.031 (26.20)	—	10	A-30069-10C2	NOT TOOLED	.661 (16.80)	.874 (22.20)	1.031 (26.20)	—
12	A-30069-12C1	NOT TOOLED	.827 (21.00)	1.039 (26.40)	1.197 (30.40)	—	12	A-30069-12C2	NOT TOOLED	.827 (21.00)	1.039 (26.40)	1.197 (30.40)	—
14	A-30069-14C1	NOT TOOLED	.992 (25.20)	1.205 (30.60)	1.362 (34.60)	—	14	A-30069-14C2	NOT TOOLED	.992 (25.20)	1.205 (30.60)	1.362 (34.60)	—
16	A-30069-16C1	NOT TOOLED	1.157 (29.40)	1.370 (34.80)	1.528 (38.80)	—	16	A-30069-16C2	NOT TOOLED	1.157 (29.40)	1.370 (34.80)	1.528 (38.80)	—
18	A-30069-18C1	NOT TOOLED	1.520 (38.60)	1.732 (44.00)	1.890 (48.00)	—	18	A-30069-18C2	NOT TOOLED	1.520 (38.60)	1.732 (44.00)	1.890 (48.00)	—
20	A-30069-20C1	NOT TOOLED	1.685 (42.80)	1.898 (48.20)	2.055 (52.20)	—	20	A-30069-20C2	NOT TOOLED	1.685 (42.80)	1.898 (48.20)	2.055 (52.20)	—
22	A-30069-22C1	NOT TOOLED	1.850 (47.00)	2.063 (52.40)	2.220 (56.40)	—	22	A-30069-22C2	NOT TOOLED	1.850 (47.00)	2.063 (52.40)	2.220 (56.40)	—
24	A-30069-24C1	NOT TOOLED	2.016 (51.20)	2.228 (56.60)	2.386 (60.60)	—	24	A-30069-24C2	NOT TOOLED	2.016 (51.20)	2.228 (56.60)	2.386 (60.60)	—
TIN-PLATED ASSEMBLIES WITH PEGS AND DRAIN HOLES.							GOLD-PLATED ASSEMBLIES WITH PEGS AND DRAIN HOLES.						
CKT. SIZE	ENG. NO.	EDP. NO.	DIM. 'A'	DIM. 'B'	DIM. 'C'	DIM. 'D'	CKT. SIZE	ENG. NO.	EDP. NO.	DIM. 'A'	DIM. 'B'	DIM. 'C'	DIM. 'D'
2	A-30069-02D1	NOT TOOLED	—	.213 (5.40)	.370 (9.40)	—	2	A-30069-02D2	NOT TOOLED	—	.213 (5.40)	.370 (9.40)	—
4	A-30069-04D1	NOT TOOLED	.165 (4.20)	.378 (9.60)	.535 (13.60)	—	4	A-30069-04D2	NOT TOOLED	.165 (4.20)	.378 (9.60)	.535 (13.60)	—
6	A-30069-06D1	15-97-7067	.331 (8.40)	.543 (13.80)	.701 (17.80)	—	6	A-30069-06D2	15-97-7069	.331 (8.40)	.543 (13.80)	.701 (17.80)	—
8	A-30069-08D1	NOT TOOLED	.496 (12.60)	.709 (18.00)	.866 (22.00)	—	8	A-30069-08D2	NOT TOOLED	.496 (12.60)	.709 (18.00)	.866 (22.00)	—
10	A-30069-10D1	NOT TOOLED	.661 (16.80)	.874 (22.20)	1.031 (26.20)	—	10	A-30069-10D2	NOT TOOLED	.661 (16.80)	.874 (22.20)	1.031 (26.20)	—
12	A-30069-12D1	NOT TOOLED	.827 (21.00)	1.039 (26.40)	1.197 (30.40)	—	12	A-30069-12D2	NOT TOOLED	.827 (21.00)	1.039 (26.40)	1.197 (30.40)	—
14	A-30069-14D1	NOT TOOLED	.992 (25.20)	1.205 (30.60)	1.362 (34.60)	—	14	A-30069-14D2	NOT TOOLED	.992 (25.20)	1.205 (30.60)	1.362 (34.60)	—
16	A-30069-16D1	NOT TOOLED	1.157 (29.40)	1.370 (34.80)	1.528 (38.80)	—	16	A-30069-16D2	NOT TOOLED	1.157 (29.40)	1.370 (34.80)	1.528 (38.80)	—
18	A-30069-18D1	NOT TOOLED	1.520 (38.60)	1.732 (44.00)	1.890 (48.00)	—	18	A-30069-18D2	NOT TOOLED	1.520 (38.60)	1.732 (44.00)	1.890 (48.00)	—
20	A-30069-20D1	NOT TOOLED	1.685 (42.80)	1.898 (48.20)	2.055 (52.20)	—	20	A-30069-20D2	NOT TOOLED	1.685 (42.80)	1.898 (48.20)	2.055 (52.20)	—
22	A-30069-22D1	NOT TOOLED	1.850 (47.00)	2.063 (52.40)	2.220 (56.40)	—	22	A-30069-22D2	NOT TOOLED	1.850 (47.00)	2.063 (52.40)	2.220 (56.40)	—
24	A-30069-24D1	NOT TOOLED	2.016 (51.20)	2.228 (56.60)	2.386 (60.60)	—	24	A-30069-24D2	NOT TOOLED	2.016 (51.20)	2.228 (56.60)	2.386 (60.60)	—

LEGEND:

A - 30069 - ** A *

CIRCUIT SIZE (02-24)

HOUSING STYLE

A = FLANGES
 B = FLANGES, DRAIN HOLES
 C = PEGS
 D = PEGS, DRAIN HOLES

PLATING (SEE SHT. 1, NOTE 6.)

1 = TIN OVER COPPER.
 2 = GOLD OVER NICKEL.

E	SEE SHT. 1
D3	SEE SHT. 1
C1	SEE SHT. 1
C	SEE SHT. 1
B	SEE SHT. 1
A	SEE SHT. 1

DIMENSIONS SHOWN (METRIC) INCH
 UNLESS OTHERWISE SPECIFIED
 TOLERANCES: ANGLES .01° ± .125°

3 PLACE	±	---	---
2 PLACE	±	---	---
1 PLACE	---	±	---

DRAFT WHERE APPLICABLE MUST REMAIN WITHIN DIMENSIONS

DRWG. BY: RJF
 APP'D: RAS

CHK'D. BY: GEP
 SCALE: --2--

MFG. SH. REV. LTR. REVISIONS

▽ = 0 ▽ = 0 **REVISE ONLY ON CAD SYSTEM**

TITLE: **MINI-FIT T.P.A. VERTICAL HEADER ASSEMBLY**

MOLEX INCORPORATED LITTLEFALL, N.J. 07643 U.S.A.
 SHEET NO. 4 DATE 9/19/91

PART NO. **SDA-30069-******
SEE CHARTS.

THIS DRAWING CONTAINS INFORMATION THAT IS PROPRIETARY TO MOLEX INC. AND SHOULD NOT BE USED WITHOUT WRITTEN PERMISSION.

CP C

NOTES:

1. HOUSING MAT'L.: POLYESTER, UNFILLED, 94V-0. COLOR: BLACK.
2. TERMINAL MATERIAL: BRASS ALLOY 260.
3. PART MATES WITH RECEPTACLE 30067-*..
4. PRODUCT SPECIFICATION: PS-5556-003
5. PART IS DESIGNED FOR USE WITH 4-40 OR M3 SCREWS.
6. PLATINGS:
 - 1 = .000035/(.00090) MIN. TIN OVER .000020/(.00050) MIN. COPPER.
 - 2 = .000030/(.00076) MIN. SELECT GOLD AND .000100/(.00254) MIN. SELECT TIN OVER .000050/(.00127) MIN. NICKEL.

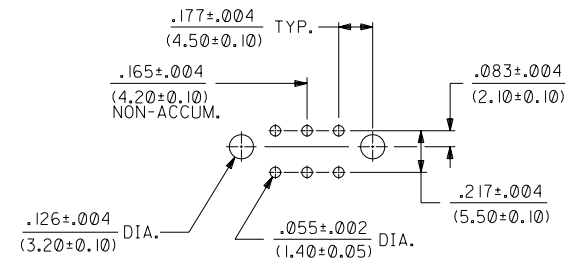
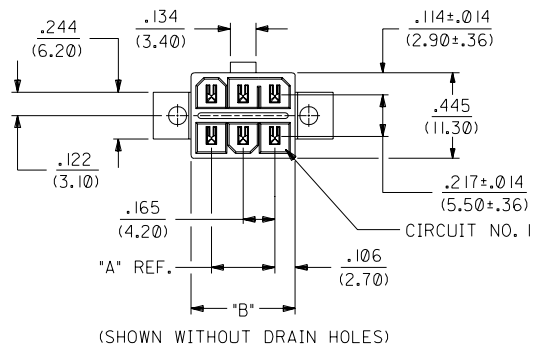
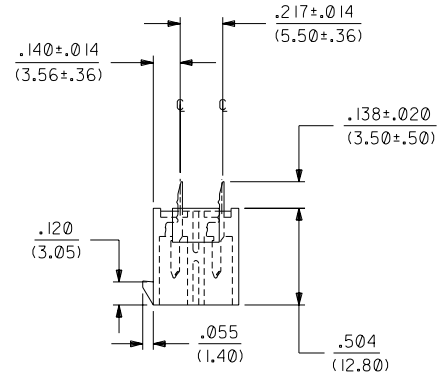
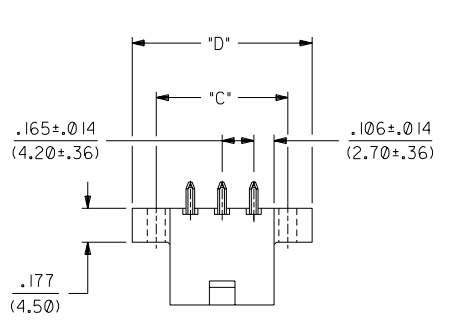

RECOMMENDED HOLE LAYOUT FOR
.070/(1.78) MAX. THICK P.C. BOARD

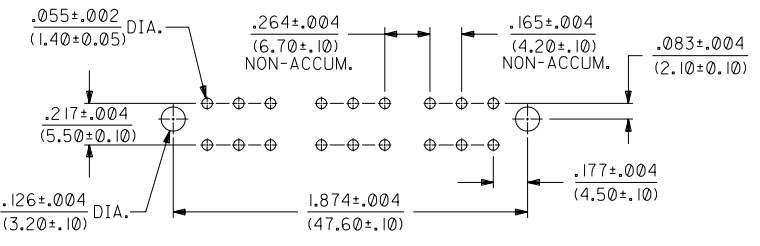

18 CIRCUIT

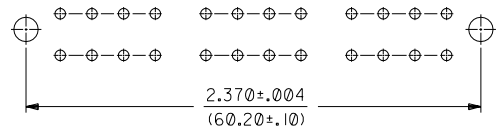

24 CIRCUIT

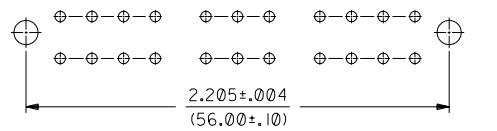

22 CIRCUIT

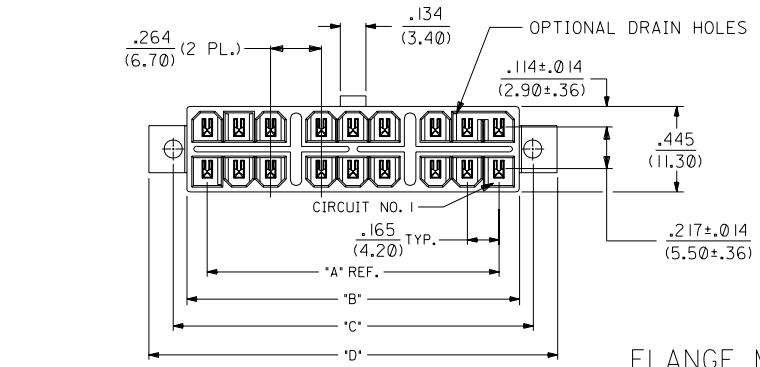

FLANGE MOUNT

(SEE SHT. 2 FOR PARTS WITH PEGS)

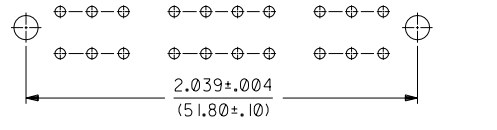

20 CIRCUIT

F	REV. PS NOTE UCF2003-0367 8/30/2002 SAMIEC
E	ADDED EDP'S PER ECN #U3-1590 93-10-27 A.GUZIK
D3	REMOVED PLAIN ECN U30726 GEP 5-14-93
D2	ADDED EDP'S PER ECR U21586 10-28-92 RJF
D1	REV. PER ECN U21270 8-26-92 RJF
D	REV. PER ECN U21043 GEP 7-14-92 RJF
C1	ADDED E.D.P.'S ECN U20701 GEP 5-1-92 RJF
C	MAT'L WAS NYLON ECR U20072 GEP 4-3-92 RJF
4	E B ADDED SHT 5 ECN U20057 GEP 1-22-92 RJF
3	E B
2	D3 A REVISED & REDRAWN ECN U11897 9-24-91 RJF
1	F A

DIMENSIONS SHOWN (METRIC) INCH UNLESS OTHERWISE SPECIFIED TOLERANCES: ANGULAR ± 1/2°		▽ = 0		REVISION ONLY ON CAD SYSTEM	
3 PLACE ± .010		INCH		METRIC	
2 PLACE ± .014		---		---	
1 PLACE ---		± 0.25		± 0.36	
DRAFT WHERE APPLICABLE MUST REMAIN WITHIN DIMENSIONS					
DRWG. BY: RJF	CHK'D. BY: GEP	FILE NAME: S30069X1.DGN	THIS DRAWING CONTAINS INFORMATION THAT IS PROPRIETARY TO MOLEX INC. AND SHOULD NOT BE USED WITHOUT WRITTEN PERMISSION.	SHEET NO. 1 OF 4	DATE 9/19/91
SEE CHARTS			SDA-30069-***		
APPR. BY: RAS	SCALE: 2:1	DRWG. NO. SDA-30069-1	DIV. CP	SIZE	

30069
 D
 C
 B
 A

TIN-PLATED ASSEMBLIES WITH FLANGES, WITHOUT DRAIN HOLES.							GOLD-PLATED ASSEMBLIES WITH FLANGES, WITHOUT DRAIN HOLES.						
CKT. SIZE	ENG. NO.	EDP. NO.	DIM. 'A'	DIM. 'B'	DIM. 'C'	DIM. 'D'	CKT. SIZE	ENG. NO.	EDP. NO.	DIM. 'A'	DIM. 'B'	DIM. 'C'	DIM. 'D'
2	A-30069-02A1	15-97-7022	—	.213 (5.40)	.354 (9.00)	.606 (15.40)	2	A-30069-02A2	15-97-7024	—	.213 (5.40)	.354 (9.00)	.606 (15.40)
4	A-30069-04A1	15-97-7042	.165 (4.20)	.378 (9.60)	.520 (13.20)	.772 (19.60)	4	A-30069-04A2	15-97-7044	.165 (4.20)	.378 (9.60)	.520 (13.20)	.772 (19.60)
6	A-30069-06A1	15-97-7062	.331 (8.40)	.543 (13.80)	.685 (17.40)	.937 (23.80)	6	A-30069-06A2	15-97-7064	.331 (8.40)	.543 (13.80)	.685 (17.40)	.937 (23.80)
8	A-30069-08A1	15-97-7082	.496 (12.60)	.709 (18.00)	.850 (21.60)	1.102 (28.00)	8	A-30069-08A2	15-97-7084	.496 (12.60)	.709 (18.00)	.850 (21.60)	1.102 (28.00)
10	A-30069-10A1	15-97-7102	.661 (16.80)	.874 (22.20)	1.016 (25.80)	1.268 (32.20)	10	A-30069-10A2	15-97-7104	.661 (16.80)	.874 (22.20)	1.016 (25.80)	1.268 (32.20)
12	A-30069-12A1	15-97-7122	.827 (21.00)	1.039 (26.40)	1.181 (30.00)	1.433 (36.40)	12	A-30069-12A2	15-97-7124	.827 (21.00)	1.039 (26.40)	1.181 (30.00)	1.433 (36.40)
14	A-30069-14A1	NOT TOOLED	.992 (25.20)	1.205 (30.60)	1.346 (34.20)	1.598 (40.60)	14	A-30069-14A2	NOT TOOLED	.992 (25.20)	1.205 (30.60)	1.346 (34.20)	1.598 (40.60)
16	A-30069-16A1	15-97-7162	1.157 (29.40)	1.370 (34.80)	1.512 (38.40)	1.764 (44.80)	16	A-30069-16A2	15-97-7164	1.157 (29.40)	1.370 (34.80)	1.512 (38.40)	1.764 (44.80)
18	A-30069-18A1	NOT TOOLED	1.520 (38.60)	1.732 (44.00)	1.874 (47.60)	2.126 (54.00)	18	A-30069-18A2	NOT TOOLED	1.520 (38.60)	1.732 (44.00)	1.874 (47.60)	2.126 (54.00)
20	A-30069-20A1	NOT TOOLED	1.685 (42.80)	1.898 (48.20)	2.039 (51.80)	2.291 (58.20)	20	A-30069-20A2	NOT TOOLED	1.685 (42.80)	1.898 (48.20)	2.039 (51.80)	2.291 (58.20)
22	A-30069-22A1	NOT TOOLED	1.850 (47.00)	2.063 (52.40)	2.205 (56.00)	2.457 (62.40)	22	A-30069-22A2	NOT TOOLED	1.850 (47.00)	2.063 (52.40)	2.205 (56.00)	2.457 (62.40)
24	A-30069-24A1	NOT TOOLED	2.016 (51.20)	2.228 (56.60)	2.370 (60.20)	2.622 (66.60)	24	A-30069-24A2	NOT TOOLED	2.016 (51.20)	2.228 (56.60)	2.370 (60.20)	2.622 (66.60)

TIN-PLATED ASSEMBLIES WITH FLANGES AND DRAIN HOLES.							GOLD-PLATED ASSEMBLIES WITH FLANGES AND DRAIN HOLES.						
CKT. SIZE	ENG. NO.	EDP. NO.	DIM. 'A'	DIM. 'B'	DIM. 'C'	DIM. 'D'	CKT. SIZE	ENG. NO.	EDP. NO.	DIM. 'A'	DIM. 'B'	DIM. 'C'	DIM. 'D'
2	A-30069-02B1	NOT TOOLED	—	.213 (5.40)	.354 (9.00)	.606 (15.40)	2	A-30069-02B2	NOT TOOLED	—	.213 (5.40)	.354 (9.00)	.606 (15.40)
4	A-30069-04B1	15-97-7046	.165 (4.20)	.378 (9.60)	.520 (13.20)	.772 (19.60)	4	A-30069-04B2	15-97-7048	.165 (4.20)	.378 (9.60)	.520 (13.20)	.772 (19.60)
6	A-30069-06B1	15-97-7066	.331 (8.40)	.543 (13.80)	.685 (17.40)	.937 (23.80)	6	A-30069-06B2	15-97-7068	.331 (8.40)	.543 (13.80)	.685 (17.40)	.937 (23.80)
8	A-30069-08B1	15-97-7086	.496 (12.60)	.709 (18.00)	.850 (21.60)	1.102 (28.00)	8	A-30069-08B2	15-97-7088	.496 (12.60)	.709 (18.00)	.850 (21.60)	1.102 (28.00)
10	A-30069-10B1	15-97-7106	.661 (16.80)	.874 (22.20)	1.016 (25.80)	1.268 (32.20)	10	A-30069-10B2	15-97-7108	.661 (16.80)	.874 (22.20)	1.016 (25.80)	1.268 (32.20)
12	A-30069-12B1	15-97-7126	.827 (21.00)	1.039 (26.40)	1.181 (30.00)	1.433 (36.40)	12	A-30069-12B2	15-97-7128	.827 (21.00)	1.039 (26.40)	1.181 (30.00)	1.433 (36.40)
14	A-30069-14B1	NOT TOOLED	.992 (25.20)	1.205 (30.60)	1.346 (34.20)	1.598 (40.60)	14	A-30069-14B2	NOT TOOLED	.992 (25.20)	1.205 (30.60)	1.346 (34.20)	1.598 (40.60)
16	A-30069-16B1	15-97-7166	1.157 (29.40)	1.370 (34.80)	1.512 (38.40)	1.764 (44.80)	16	A-30069-16B2	15-97-7168	1.157 (29.40)	1.370 (34.80)	1.512 (38.40)	1.764 (44.80)
18	A-30069-18B1	NOT TOOLED	1.520 (38.60)	1.732 (44.00)	1.874 (47.60)	2.126 (54.00)	18	A-30069-18B2	NOT TOOLED	1.520 (38.60)	1.732 (44.00)	1.874 (47.60)	2.126 (54.00)
20	A-30069-20B1	NOT TOOLED	1.685 (42.80)	1.898 (48.20)	2.039 (51.80)	2.291 (58.20)	20	A-30069-20B2	NOT TOOLED	1.685 (42.80)	1.898 (48.20)	2.039 (51.80)	2.291 (58.20)
22	A-30069-22B1	NOT TOOLED	1.850 (47.00)	2.063 (52.40)	2.205 (56.00)	2.457 (62.40)	22	A-30069-22B2	NOT TOOLED	1.850 (47.00)	2.063 (52.40)	2.205 (56.00)	2.457 (62.40)
24	A-30069-24B1	NOT TOOLED	2.016 (51.20)	2.228 (56.60)	2.370 (60.20)	2.622 (66.60)	24	A-30069-24B2	NOT TOOLED	2.016 (51.20)	2.228 (56.60)	2.370 (60.20)	2.622 (66.60)

LEGEND:

A - 30069 - ** A *

CIRCUIT SIZE (02-24)

HOUSING STYLE

A = FLANGES
B = FLANGES, DRAIN HOLES
C = PEGS
D = PEGS, DRAIN HOLES

PLATING

1 = TIN OVER COPPER.
2 = 30' GOLD OVER NICKEL.

E	SEE SHT. 1
D3	SEE SHT. 1
D2	SEE SHT. 1
C1	SEE SHT. 1
C	SEE SHT. 1
B	SEE SHT. 1
A	SEE SHEET 1

DIMENSIONS SHOWN (METRIC) INCH UNLESS OTHERWISE SPECIFIED TOLERANCES ANGLES ARE ± 1/2°

DRAFT WHERE APPLICABLE MUST REMAIN WITHIN DIMENSIONS

DRWG. BY: R/JF CHK'D. BY: GEP
APP'D. BY: RAS SCALE: --2--

MFG. SH. REV. LTR. REVISIONS

REVISIONS

TITLE: MINI-FIT T.P.A. VERTICAL HEADER ASSEMBLY

PART NO. SEE CHARTS. SDA-30069-****

MOLEX INCORPORATED LITTLEVILLE, MISSOURI 60532 U.S.A.

SHEET NO. 3 DATE 9/19/91

THIS DRAWING CONTAINS INFORMATION THAT IS PROPRIETARY TO MOLEX INC. AND SHOULD NOT BE USED WITHOUT WRITTEN PERMISSION.

CP C

TIN-PLATED ASSEMBLIES WITH PEGS, WITHOUT DRAIN HOLES.							GOLD-PLATED ASSEMBLIES WITH PEGS, WITHOUT DRAIN HOLES.						
CKT. SIZE	ENG. NO.	EDP. NO.	DIM. 'A'	DIM. 'B'	DIM. 'C'	DIM. 'D'	CKT. SIZE	ENG. NO.	EDP. NO.	DIM. 'A'	DIM. 'B'	DIM. 'C'	DIM. 'D'
2	A-30069-02C1	NOT TOOLED	—	.213 (5.40)	.370 (9.40)	—	2	A-30069-02C2	NOT TOOLED	—	.213 (5.40)	.370 (9.40)	—
4	A-30069-04C1	NOT TOOLED	.165 (4.20)	.378 (9.60)	.535 (13.60)	—	4	A-30069-04C2	NOT TOOLED	.165 (4.20)	.378 (9.60)	.535 (13.60)	—
6	A-30069-06C1	15-97-7063	.331 (8.40)	.543 (13.80)	.701 (17.80)	—	6	A-30069-06C2	15-97-7065	.331 (8.40)	.543 (13.80)	.701 (17.80)	—
8	A-30069-08C1	NOT TOOLED	.496 (12.60)	.709 (18.00)	.866 (22.00)	—	8	A-30069-08C2	NOT TOOLED	.496 (12.60)	.709 (18.00)	.866 (22.00)	—
10	A-30069-10C1	NOT TOOLED	.661 (16.80)	.874 (22.20)	1.031 (26.20)	—	10	A-30069-10C2	NOT TOOLED	.661 (16.80)	.874 (22.20)	1.031 (26.20)	—
12	A-30069-12C1	NOT TOOLED	.827 (21.00)	1.039 (26.40)	1.197 (30.40)	—	12	A-30069-12C2	NOT TOOLED	.827 (21.00)	1.039 (26.40)	1.197 (30.40)	—
14	A-30069-14C1	NOT TOOLED	.992 (25.20)	1.205 (30.60)	1.362 (34.60)	—	14	A-30069-14C2	NOT TOOLED	.992 (25.20)	1.205 (30.60)	1.362 (34.60)	—
16	A-30069-16C1	NOT TOOLED	1.157 (29.40)	1.370 (34.80)	1.528 (38.80)	—	16	A-30069-16C2	NOT TOOLED	1.157 (29.40)	1.370 (34.80)	1.528 (38.80)	—
18	A-30069-18C1	NOT TOOLED	1.520 (38.60)	1.732 (44.00)	1.890 (48.00)	—	18	A-30069-18C2	NOT TOOLED	1.520 (38.60)	1.732 (44.00)	1.890 (48.00)	—
20	A-30069-20C1	NOT TOOLED	1.685 (42.80)	1.898 (48.20)	2.055 (52.20)	—	20	A-30069-20C2	NOT TOOLED	1.685 (42.80)	1.898 (48.20)	2.055 (52.20)	—
22	A-30069-22C1	NOT TOOLED	1.850 (47.00)	2.063 (52.40)	2.220 (56.40)	—	22	A-30069-22C2	NOT TOOLED	1.850 (47.00)	2.063 (52.40)	2.220 (56.40)	—
24	A-30069-24C1	NOT TOOLED	2.016 (51.20)	2.228 (56.60)	2.386 (60.60)	—	24	A-30069-24C2	NOT TOOLED	2.016 (51.20)	2.228 (56.60)	2.386 (60.60)	—
TIN-PLATED ASSEMBLIES WITH PEGS AND DRAIN HOLES.							GOLD-PLATED ASSEMBLIES WITH PEGS AND DRAIN HOLES.						
CKT. SIZE	ENG. NO.	EDP. NO.	DIM. 'A'	DIM. 'B'	DIM. 'C'	DIM. 'D'	CKT. SIZE	ENG. NO.	EDP. NO.	DIM. 'A'	DIM. 'B'	DIM. 'C'	DIM. 'D'
2	A-30069-02D1	NOT TOOLED	—	.213 (5.40)	.370 (9.40)	—	2	A-30069-02D2	NOT TOOLED	—	.213 (5.40)	.370 (9.40)	—
4	A-30069-04D1	NOT TOOLED	.165 (4.20)	.378 (9.60)	.535 (13.60)	—	4	A-30069-04D2	NOT TOOLED	.165 (4.20)	.378 (9.60)	.535 (13.60)	—
6	A-30069-06D1	15-97-7067	.331 (8.40)	.543 (13.80)	.701 (17.80)	—	6	A-30069-06D2	15-97-7069	.331 (8.40)	.543 (13.80)	.701 (17.80)	—
8	A-30069-08D1	NOT TOOLED	.496 (12.60)	.709 (18.00)	.866 (22.00)	—	8	A-30069-08D2	NOT TOOLED	.496 (12.60)	.709 (18.00)	.866 (22.00)	—
10	A-30069-10D1	NOT TOOLED	.661 (16.80)	.874 (22.20)	1.031 (26.20)	—	10	A-30069-10D2	NOT TOOLED	.661 (16.80)	.874 (22.20)	1.031 (26.20)	—
12	A-30069-12D1	NOT TOOLED	.827 (21.00)	1.039 (26.40)	1.197 (30.40)	—	12	A-30069-12D2	NOT TOOLED	.827 (21.00)	1.039 (26.40)	1.197 (30.40)	—
14	A-30069-14D1	NOT TOOLED	.992 (25.20)	1.205 (30.60)	1.362 (34.60)	—	14	A-30069-14D2	NOT TOOLED	.992 (25.20)	1.205 (30.60)	1.362 (34.60)	—
16	A-30069-16D1	NOT TOOLED	1.157 (29.40)	1.370 (34.80)	1.528 (38.80)	—	16	A-30069-16D2	NOT TOOLED	1.157 (29.40)	1.370 (34.80)	1.528 (38.80)	—
18	A-30069-18D1	NOT TOOLED	1.520 (38.60)	1.732 (44.00)	1.890 (48.00)	—	18	A-30069-18D2	NOT TOOLED	1.520 (38.60)	1.732 (44.00)	1.890 (48.00)	—
20	A-30069-20D1	NOT TOOLED	1.685 (42.80)	1.898 (48.20)	2.055 (52.20)	—	20	A-30069-20D2	NOT TOOLED	1.685 (42.80)	1.898 (48.20)	2.055 (52.20)	—
22	A-30069-22D1	NOT TOOLED	1.850 (47.00)	2.063 (52.40)	2.220 (56.40)	—	22	A-30069-22D2	NOT TOOLED	1.850 (47.00)	2.063 (52.40)	2.220 (56.40)	—
24	A-30069-24D1	NOT TOOLED	2.016 (51.20)	2.228 (56.60)	2.386 (60.60)	—	24	A-30069-24D2	NOT TOOLED	2.016 (51.20)	2.228 (56.60)	2.386 (60.60)	—

LEGEND:

A - 30069 - ** A *

CIRCUIT SIZE (02-24)

HOUSING STYLE

A = FLANGES
 B = FLANGES, DRAIN HOLES
 C = PEGS
 D = PEGS, DRAIN HOLES

PLATING (SEE SHT. 1, NOTE 6.)

1 = TIN OVER COPPER.
 2 = GOLD OVER NICKEL.

E	SEE SHT. 1
D3	SEE SHT. 1
C1	SEE SHT. 1
C	SEE SHT. 1
B	SEE SHT. 1
A	SEE SHT. 1

DIMENSIONS SHOWN METRIC INCH
 UNLESS OTHERWISE SPECIFIED
 TOLERANCES ANGLES ARE 1/2°

3 PLACE	± .001	± .001
2 PLACE	± .005	± .005
1 PLACE	± .010	± .010

DRAFT WHERE APPLICABLE MUST REMAIN WITHIN DIMENSIONS

DRWG. BY: RJF
 APP'D: RAS

CHK'D. BY: GEP
 SCALE: -- 2 --

MFG. SH. REV. LTR. REVISIONS

▽ = 0 ▽ = 0 **REVISE ONLY ON CAD SYSTEM**

TITLE: **MINI-FIT T.P.A. VERTICAL HEADER ASSEMBLY**

MOLEX INCORPORATED LITTLE ROCK, AR 60532 U.S.A.

PART NO. **SDA-30069-****** SHEET NO. 4 DATE 9/19/91

SEE CHARTS.

THIS DRAWING CONTAINS INFORMATION THAT IS PROPRIETARY TO MOLEX INC. AND SHOULD NOT BE USED WITHOUT WRITTEN PERMISSION.

CP C