

# HUH7285/HUH7286

## For CD-R/RW Drivers Hologram Unit

For optical information processing  
(Recordable × 24 speed + readable × 48 speed)

### ■ Features

- It is developed real with window structured high power laser diode, and realized high speed recording
- 24 × writing/48 × reading of CD-R/RW possible
- Thin (4.0 mm) package realizes thin and simple pick-up

### ■ Applications

- CD-R/RW

### ■ Tracking error signal output pin count

- HUH7285: 4 pins
- HUH7286: 2 pins

### ■ Absolute Maximum Ratings

Parameter	Symbol	Rating	Unit
Radiant power	$P_O$	90 (CW), 162 (pulse)	mW
Reverse voltage	$V_{R(LD)}$	1.5	V
Supply voltage	$V_{CC}$	6	V
Reference voltage	$V_{ref}$	+1.5 to +2.3	V
Operating ambient temperature	$T_{opr}$	-10 to +60	°C
Storage temperature	$T_{stg}$	-40 to +85	°C

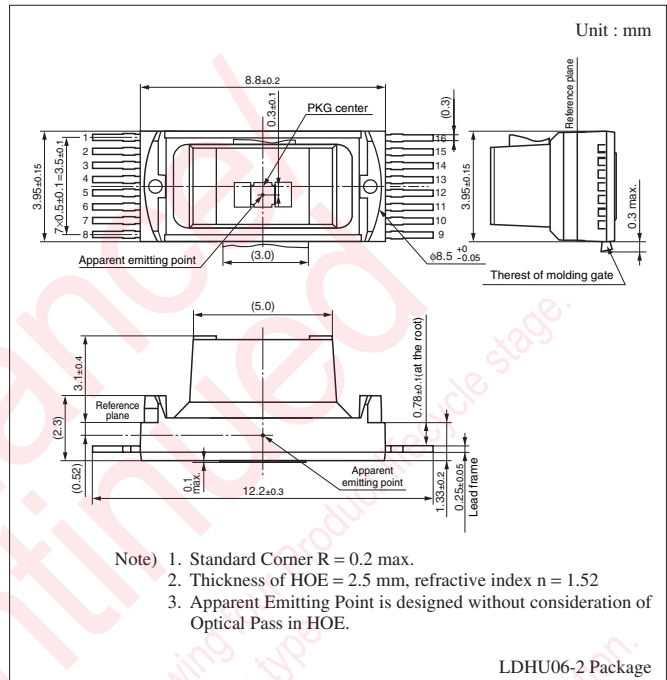

■ Block Diagrams

• HUH7285

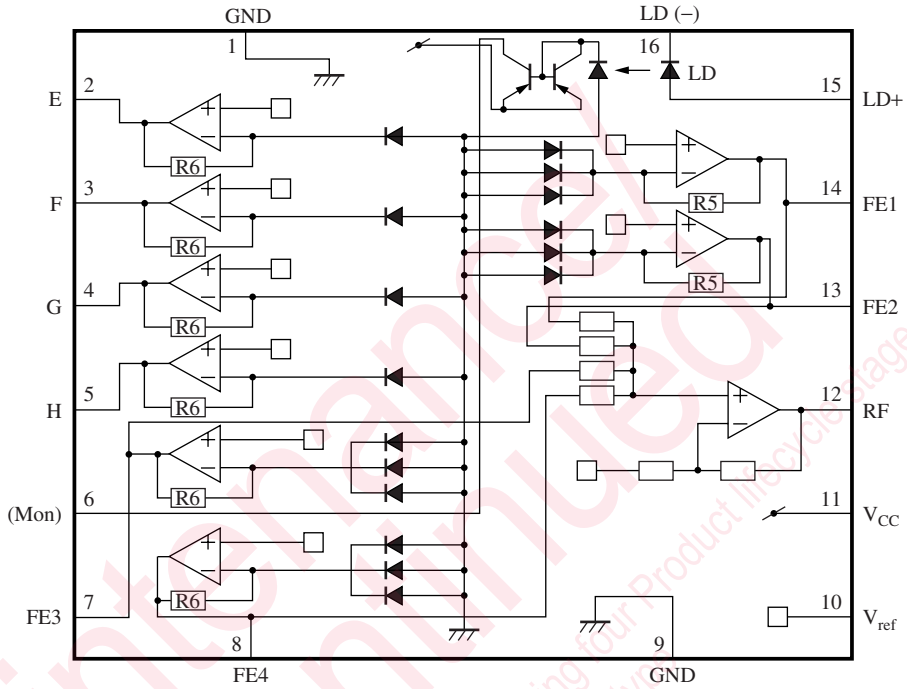

• HUH7286

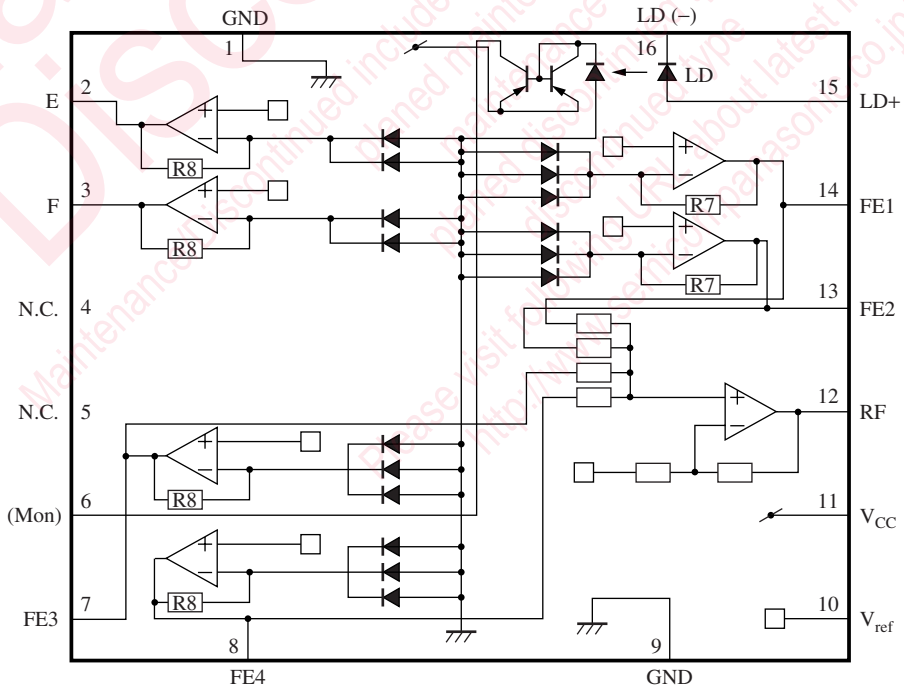

## ■ Pin Descriptions

### • HUH7285

Pin No.	Description	Pin No.	Description
1	GND	9	GND
2	E Signal out ( $V_E$ )	10	$V_{ref}$
3	F Signal out ( $V_F$ )	11	$V_{CC}$
4	G Signal out ( $V_G$ )	12	RF
5	H Signal out ( $V_H$ )	13	FE2 Signal out ( $V_{FE2}$ )
6 *	(Mon. out) value not guaranteed	14	FE1 Signal out ( $V_{FE1}$ )
7	FE3 Signal out ( $V_{FE3}$ )	15	LD(+)
8	FE4 Signal out ( $V_{FE4}$ )	16	LD(-)

Note) \*: The pin 6 must be connected to GND level.

### • HUH7286

Pin No.	Description	Pin No.	Description
1	GND	9	GND
2	E Signal out ( $V_E$ )	10	$V_{ref}$
3	F Signal out ( $V_F$ )	11	$V_{CC}$
4	N.C.	12	RF
5	N.C.	13	FE2 Signal out ( $V_{FE2}$ )
6 *	(Mon. out) value not guaranteed	14	FE1 Signal out ( $V_{FE1}$ )
7	FE3 Signal out ( $V_{FE3}$ )	15	LD(+)
8	FE4 Signal out ( $V_{FE4}$ )	16	LD(-)

Note) \*: The pin 6 must be connected to GND level.

## ■ Electro-Optical Characteristics

### • Unit characteristic specifications $T_C = 25^\circ\text{C} \pm 3^\circ\text{C}$

Parameter	Symbol	Conditions	Min	Typ	Max	Unit
Threshold current	$I_{th}$	CW	15	26	40	mA
Operating current	$I_{OP}$	CW, $P_O = 80 \text{ mW}$	85	105	125	mA
Operating voltage	$V_{OP}$		1.6	1.9	2.5	V
Oscillation wavelength	$\lambda$		779	785	791	nm
Focus error signal amplitude	$V_{FE}$	$P_{LO} = 0.8 \text{ mW}$ , $V_{CC} = 5 \text{ V}$ , $V_{ref} = 1.65 \text{ V}$	80	135	190	mV
Focus error signal balance	$B_{FE}$		-20	0	+20	%
Main beam signal amount	$V_{TE}$		105	175	245	mV
Main beam signal balance	$B_{TE}$		-30	0	+30	%
Sub beam signal amount	$V_{TC}$		70	120	170	mV
RF signal amount	$V_{RF}$		240	400	560	mV

# Caution for Safety

 **DANGER**

■ **This product contains Gallium Arsenide (GaAs).**

GaAs powder and vapor are hazardous to human health if inhaled or ingested. Do not burn, destroy, cut, cleave off, or chemically dissolve the product. Follow related laws and ordinances for disposal. The product should be excluded from general industrial waste or household garbage.

■ **Do not touch or look into the laser beam directly.**

The laser beam may cause injury to the eye or skin, or loss of eyesight.

## Request for your special attention and precautions in using the technical information and semiconductors described in this book

- (1) If any of the products or technical information described in this book is to be exported or provided to non-residents, the laws and regulations of the exporting country, especially, those with regard to security export control, must be observed.
- (2) The technical information described in this book is intended only to show the main characteristics and application circuit examples of the products, and no license is granted under any intellectual property right or other right owned by our company or any other company. Therefore, no responsibility is assumed by our company as to the infringement upon any such right owned by any other company which may arise as a result of the use of technical information described in this book.
- (3) The products described in this book are intended to be used for standard applications or general electronic equipment (such as office equipment, communications equipment, measuring instruments and household appliances).  
Consult our sales staff in advance for information on the following applications:
  - Special applications (such as for airplanes, aerospace, automobiles, traffic control equipment, combustion equipment, life support systems and safety devices) in which exceptional quality and reliability are required, or if the failure or malfunction of the products may directly jeopardize life or harm the human body.
  - Any applications other than the standard applications intended.
- (4) The products and product specifications described in this book are subject to change without notice for modification and/or improvement. At the final stage of your design, purchasing, or use of the products, therefore, ask for the most up-to-date Product Standards in advance to make sure that the latest specifications satisfy your requirements.
- (5)  When designing your equipment, comply with the range of absolute maximum rating and the guaranteed operating conditions (operating power supply voltage and operating environment etc.). Especially, please be careful not to exceed the range of absolute maximum rating on the transient state, such as power-on, power-off and mode-switching. Otherwise, we will not be liable for any defect which may arise later in your equipment.
  - Even when the products are used within the guaranteed values, take into the consideration of incidence of break down and failure mode, possible to occur to semiconductor products. Measures on the systems such as redundant design, arresting the spread of fire or preventing glitch are recommended in order to prevent physical injury, fire, social damages, for example, by using the products.
- (6) Comply with the instructions for use in order to prevent breakdown and characteristics change due to external factors (ESD, EOS, thermal stress and mechanical stress) at the time of handling, mounting or at customer's process. When using products for which damp-proof packing is required, satisfy the conditions, such as shelf life and the elapsed time since first opening the packages.
- (7)  This book may be not reprinted or reproduced whether wholly or partially, without the prior written permission of Matsushita Electric Industrial Co., Ltd.

- If you have any inquiries or questions about this book or our semiconductor products, please contact one of our sales offices listed on the back or Semiconductor Company's Department.