

REVISIONS

LTR	DESCRIPTION	DATE (YR-MO-DA)	APPROVED
A	Convert to military drawing format. Add vendor CAGE 27014 for device type 01EX and 012X.	87-01-27	Nelson A. Hauck
B	Update boilerplate to MIL-PRF-38535 requirements. - jak	01-11-26	Thomas M. Hess

The first page of this drawing has been changed.

Current CAGE CODE is 67268

REV																			
SHEET																			
REV																			
SHEET																			
REV STATUS OF SHEETS	REV	B	B	B	B	B	B	B	B	B	B	B	B	B	B	B	B	B	B
	SHEET	1	2	3	4	5	6	7	8	9	10	11	12	13	14				
PMIC N/A	PREPARED BY Jeffery Tunstall	<p align="center">DEFENSE SUPPLY CENTER COLUMBUS</p> <p align="center">COLUMBUS, OHIO 43216 http://www.dscc.dla.mil</p>																	
STANDARD MICROCIRCUIT DRAWING	CHECKED BY D. A. DiCenzo																		
THIS DRAWING IS AVAILABLE FOR USE BY ALL DEPARTMENTS AND AGENCIES OF THE DEPARTMENT OF DEFENSE AMSC N/A	APPROVED BY Nelson A. Hauck																		
	DRAWING APPROVAL DATE 86-01-22	MICROCIRCUIT, DIGITAL, HIGH-SPEED CMOS, DECADE COUNTER/DIVIDER, MONOLITHIC SILICON																	
	REVISION LEVEL B	SIZE A	CAGE CODE 14933	86011															
		SHEET 1 OF 14																	

1. SCOPE

1.1 Scope. This drawing describes device requirements for MIL-STD-883 compliant, non-JAN class level B microcircuits in accordance with MIL-PRF-38535, appendix A.

1.2 Part or Identifying Number (PIN). The complete PIN is as shown in the following example:

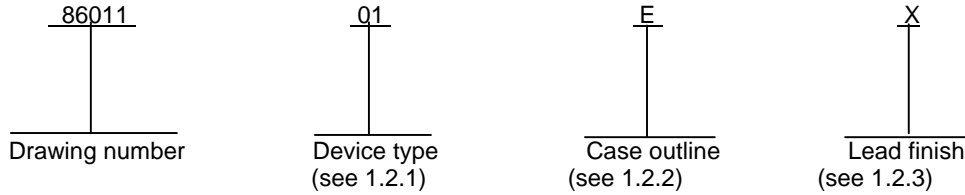

1.2.1 Device types. The device types identify the circuit function as follows:

Device type	Generic number	Circuit function
01	54HC4017	Decade counter/divider

1.2.2 Case outlines. The case outlines are as designated in MIL-STD-1835 and as follows:

Outline letter	Descriptive designator	Terminals	Package style
E	GDIP1-T16 or CDIP2-T16	16	Dual-in-line
2	CQCC1-N20	20	Square leadless chip carrier

1.2.3 Lead finish. The lead finish is as specified in MIL-PRF-38535, appendix A.

1.3 Absolute maximum ratings. 1/

Supply voltage range (V_{CC}).....	-0.5 V dc to +7.0 V dc
DC input voltage	-0.5 V dc to $V_{CC} + 0.5$ V dc
DC output voltage	-0.5 V dc to $V_{CC} + 0.5$ V dc
Clamp diode current	± 20 mA
DC output current (per pin).....	± 25 mA
DC V_{CC} or GND current (per pin).....	± 50 mA
Storage temperature range (T_{STG}).....	-65°C to +150°C
Maximum power dissipation (P_D).....	500 mW 2/
Lead temperature (soldering, 10 seconds).....	+260°C
Thermal resistance, junction-to-case (θ_{JC})	See MIL-STD-1835
Junction temperature (T_J).....	+175°C

1/ Unless otherwise specified, all voltages are referenced to ground.

2/ For $T_C = +100^\circ\text{C}$ to $+125^\circ\text{C}$, derate linearly at 12 mW/°C.

STANDARD MICROCIRCUIT DRAWING DEFENSE SUPPLY CENTER COLUMBUS COLUMBUS, OHIO 43216-5000	SIZE A		86011
		REVISION LEVEL B	SHEET 2

1.4 Recommended operating conditions.

Supply voltage range (V_{CC}).....	+2.0 V dc to +6.0 V dc
Case operating temperature range (T_C)	-55°C to +125°C
Minimum setup time, enable to clock (t_s):	
$T_C = +25^\circ\text{C}$:	
$V_{CC} = 2.0 \text{ V}$	75 ns
$V_{CC} = 4.5 \text{ V}$	15 ns
$V_{CC} = 6.0 \text{ V}$	13 ns
$T_C = -55^\circ\text{C}$ to 125°C :	
$V_{CC} = 2.0 \text{ V}$	110 ns
$V_{CC} = 4.5 \text{ V}$	22 ns
$V_{CC} = 6.0 \text{ V}$	19 ns
Minimum clock input pulse width (t_{w1})	
$T_C = +25^\circ\text{C}$:	
$V_{CC} = 2.0 \text{ V}$	100 ns
$V_{CC} = 4.5 \text{ V}$	20 ns
$V_{CC} = 6.0 \text{ V}$	17 ns
$T_C = -55^\circ\text{C}$ to 125°C :	
$V_{CC} = 2.0 \text{ V}$	150 ns
$V_{CC} = 4.5 \text{ V}$	30 ns
$V_{CC} = 6.0 \text{ V}$	26 ns
Minimum hold time, clock to enable (t_h):	
$T_C = +25^\circ\text{C}$:	
$V_{CC} = 2.0 \text{ V}$	75 ns
$V_{CC} = 4.5 \text{ V}$	15 ns
$V_{CC} = 6.0 \text{ V}$	13 ns
$T_C = -55^\circ\text{C}$ to 125°C :	
$V_{CC} = 2.0 \text{ V}$	110 ns
$V_{CC} = 4.5 \text{ V}$	22 ns
$V_{CC} = 6.0 \text{ V}$	19 ns
Minimum pulse width, reset input (t_{w2}):	
$T_C = +25^\circ\text{C}$:	
$V_{CC} = 2.0 \text{ V}$	80 ns
$V_{CC} = 4.5 \text{ V}$	16 ns
$V_{CC} = 6.0 \text{ V}$	14 ns
$T_C = -55^\circ\text{C}$ to 125°C :	
$V_{CC} = 2.0 \text{ V}$	120 ns
$V_{CC} = 4.5 \text{ V}$	24 ns
$V_{CC} = 6.0 \text{ V}$	20 ns
Minimum enable pulse width (t_{w3})	
$T_C = +25^\circ\text{C}$:	
$V_{CC} = 2.0 \text{ V}$	100 ns
$V_{CC} = 4.5 \text{ V}$	20 ns
$V_{CC} = 6.0 \text{ V}$	17 ns
$T_C = -55^\circ\text{C}$ to 125°C :	
$V_{CC} = 2.0 \text{ V}$	150 ns
$V_{CC} = 4.5 \text{ V}$	30 ns
$V_{CC} = 6.0 \text{ V}$	26 ns
Minimum recovery time, reset to clock (t_{rec}):	
$T_C = +25^\circ\text{C}$:	
$V_{CC} = 2.0 \text{ V}$	100 ns
$V_{CC} = 4.5 \text{ V}$	20 ns
$V_{CC} = 6.0 \text{ V}$	17 ns
$T_C = -55^\circ\text{C}$ to 125°C :	
$V_{CC} = 2.0 \text{ V}$	150 ns
$V_{CC} = 4.5 \text{ V}$	30 ns
$V_{CC} = 6.0 \text{ V}$	26 ns

STANDARD MICROCIRCUIT DRAWING DEFENSE SUPPLY CENTER COLUMBUS COLUMBUS, OHIO 43216-5000	SIZE A		86011
		REVISION LEVEL B	SHEET 3

Maximum clock frequency (f_{MAX}):

$T_C = +25^\circ\text{C}$:

$V_{CC} = 2.0\text{ V}$ 4 MHz

$V_{CC} = 4.5\text{ V}$ 20 MHz

$V_{CC} = 6.0\text{ V}$ 24 MHz

$T_C = -55^\circ\text{C}$ to 125°C :

$V_{CC} = 2.0\text{ V}$ 2.6 MHz

$V_{CC} = 4.5\text{ V}$ 13 MHz

$V_{CC} = 6.0\text{ V}$ 15 MHz

2. APPLICABLE DOCUMENTS

2.1 Government specification, standards, and handbooks. The following specification, standards, and handbooks form a part of this drawing to the extent specified herein. Unless otherwise specified, the issues of these documents are those listed in the issue of the Department of Defense Index of Specifications and Standards (DoDISS) and supplement thereto, cited in the solicitation.

SPECIFICATION

DEPARTMENT OF DEFENSE

MIL-PRF-38535 - Integrated Circuits, Manufacturing, General Specification for.

STANDARDS

DEPARTMENT OF DEFENSE

MIL-STD-883 - Test Method Standard Microcircuits.

MIL-STD-1835 - Interface Standard Electronic Component Case Outlines.

HANDBOOKS

DEPARTMENT OF DEFENSE

MIL-HDBK-103 - List of Standard Microcircuit Drawings.

MIL-HDBK-780 - Standard Microcircuit Drawings.

(Unless otherwise indicated, copies of the specification, standards, and handbooks are available from the Standardization Document Order Desk, 700 Robbins Avenue, Building 4D, Philadelphia, PA 19111-5094.)

2.2 Order of precedence. In the event of a conflict between the text of this drawing and the references cited herein, the text of this drawing takes precedence. Nothing in this document, however, supersedes applicable laws and regulations unless a specific exemption has been obtained.

3. REQUIREMENTS

3.1 Item requirements. The individual item requirements shall be in accordance with MIL-PRF-38535, appendix A for non-JAN class level B devices and as specified herein. Product built to this drawing that is produced by a Qualified Manufacturer Listing (QML) certified and qualified manufacturer or a manufacturer who has been granted transitional certification to MIL-PRF-38535 may be processed as QML product in accordance with the manufacturers approved program plan and qualifying activity approval in accordance with MIL-PRF-38535. This QML flow as documented in the Quality Management (QM) plan may make modifications to the requirements herein. These modifications shall not affect form, fit, or function of the device. These modifications shall not affect the PIN as described herein. A "Q" or "QML" certification mark in accordance with MIL-PRF-38535 is required to identify when the QML flow option is used.

3.2 Design, construction, and physical dimensions. The design, construction, and physical dimensions shall be as specified in MIL-PRF-38535, appendix A and herein.

STANDARD MICROCIRCUIT DRAWING DEFENSE SUPPLY CENTER COLUMBUS COLUMBUS, OHIO 43216-5000	SIZE A		86011
		REVISION LEVEL B	SHEET 4

3.2.1 Case outlines. The case outlines shall be in accordance with 1.2.2 herein.

3.2.2 Terminal connections. The terminal connections shall be as specified on figure 1.

3.2.3 Truth table. The truth table shall be as specified on figure 2.

3.2.4 Logic diagram. The logic diagram shall be as specified on figure 3.

3.2.5 Counting sequence. The counting sequence shall be as specified on figure 4.

3.2.6 Switching waveforms and test circuit. The switching waveforms and test circuit shall be as specified on figure 5.

3.3 Electrical performance characteristics. Unless otherwise specified herein, the electrical performance characteristics are as specified in table I and shall apply over the full case operating temperature range.

3.4 Electrical test requirements. The electrical test requirements shall be the subgroups specified in table II. The electrical tests for each subgroup are described in table I.

3.5 Marking. Marking shall be in accordance with MIL-PRF-38535, appendix A. The part shall be marked with the PIN listed in 1.2 herein. In addition, the manufacturer's PIN may also be marked as listed in MIL-HDBK-103 (see 6.6 herein). For packages where marking of the entire SMD PIN number is not feasible due to space limitations, the manufacturer has the option of not marking the "5962-" on the device.

3.5.1 Certification/compliance mark. A compliance indicator "C" shall be marked on all non-JAN devices built in compliance to MIL-PRF-38535, appendix A. The compliance indicator "C" shall be replaced with a "Q" or "QML" certification mark in accordance with MIL-PRF-38535 to identify when the QML flow option is used.

3.6 Certificate of compliance. A certificate of compliance shall be required from a manufacturer in order to be listed as an approved source of supply in MIL-HDBK-103 and QML-38535 (see 6.6 herein). The certificate of compliance submitted to DSCC-VA prior to listing as an approved source of supply shall affirm that the manufacturer's product meets the requirements of MIL-PRF-38535, appendix A and the requirements herein.

3.7 Certificate of conformance. A certificate of conformance as required in MIL-PRF-38535, appendix A shall be provided with each lot of microcircuits delivered to this drawing.

3.8 Notification of change. Notification of change to DSCC-VA shall be required in accordance with MIL-PRF-38535, appendix A.

3.9 Verification and review. DSCC, DSCC's agent, and the acquiring activity retain the option to review the manufacturer's facility and applicable required documentation. Offshore documentation shall be made available onshore at the option of the reviewer.

STANDARD MICROCIRCUIT DRAWING DEFENSE SUPPLY CENTER COLUMBUS COLUMBUS, OHIO 43216-5000	SIZE A		86011
		REVISION LEVEL B	SHEET 5

Table I. Electrical performance characteristics.

Test	Symbol	Test conditions -55°C ≤ T _C ≤ +125°C 1/ unless otherwise specified		Group A subgroups	Limits		Unit
					Min	Max	
High-level output voltage	V _{OH}	V _{IN} = V _{IH} or V _{IL} I _O ≤ 20 μA	V _{CC} = 2.0 V	1, 2, 3	1.9		V
			V _{CC} = 4.5 V		4.4		
			V _{CC} = 6.0 V		5.9		
		V _{IN} = V _{IH} or V _{IL} I _O ≤ 4.0 mA	V _{CC} = 4.5 V		3.7		
		V _{IN} = V _{IH} or V _{IL} I _O ≤ 5.2 mA	V _{CC} = 6.0 V		5.2		
Low-level output voltage	V _{OL}	V _{IN} = V _{IH} or V _{IL} I _O ≤ 20 μA	V _{CC} = 2.0 V	1, 2, 3		0.1	V
			V _{CC} = 4.5 V			0.1	
			V _{CC} = 6.0 V			0.1	
		V _{IN} = V _{IH} or V _{IL} I _O ≤ 4.0 mA	V _{CC} = 4.5 V			0.4	
		V _{IN} = V _{IH} or V _{IL} I _O ≤ 5.2 mA	V _{CC} = 6.0 V			0.4	
High-level input voltage	V _{IH} 2/		V _{CC} = 2.0 V	1, 2, 3	1.5		V
			V _{CC} = 4.5 V		3.15		
			V _{CC} = 6.0 V		4.2		
Low-level input voltage	V _{IL} 2/		V _{CC} = 2.0 V	1, 2, 3		0.3	V
			V _{CC} = 4.5 V			0.9	
			V _{CC} = 6.0 V			1.2	
Input capacitance	C _{IN}	V _{IN} = 0.0 V, T _C = +25°C See 4.3.1c		4		10	pF
Quiescent current	I _{CC}	V _{IN} = V _{CC} or GND V _{CC} = 6.0 V		1, 2, 3		160	μA
Input leakage current	I _{IN}	V _{IN} = V _{CC} or GND V _{CC} = 6.0 V		1, 2, 3		±1.0	μA
Functional tests		See 4.3.1d		7			
Propagation delay, time, CP to Qn	t _{PLH1} , t _{PHL1} 3/	C _L = 50 pF See figure 5	V _{CC} = 2.0 V	1, 2, 3		230	ns
					9	345	
			V _{CC} = 4.5 V		9	46	
					10, 11	69	
			V _{CC} = 6.0 V		9	39	
					10, 11	59	

See footnotes at end of table.

STANDARD MICROCIRCUIT DRAWING DEFENSE SUPPLY CENTER COLUMBUS COLUMBUS, OHIO 43216-5000	SIZE A		86011
		REVISION LEVEL B	SHEET 6

Table I. Electrical performance characteristics - Continued.

Test	Symbol	Test conditions -55°C ≤ T _C ≤ +125°C 1/ unless otherwise specified	Group A subgroups	Limits		Unit	
				Min	Max		
Propagation delay, time, CP to CO	t _{PLH2} , t _{PHL2}	C _L = 50 pF See figure 5	V _{CC} = 2.0 V	9		230	ns
				10, 11		345	
	V _{CC} = 4.5 V		9		46		
			10, 11		69		
	V _{CC} = 6.0 V		9		39		
			10, 11		59		
Propagation delay, time, CE to CO	t _{PHL3} , t _{PLH3}	C _L = 50 pF See figure 5	V _{CC} = 2.0 V	9		250	ns
				10, 11		375	
	V _{CC} = 4.5 V		9		50		
			10, 11		75		
	V _{CC} = 6.0 V		9		43		
			10, 11		64		
Propagation delay, time, CE to Qn	t _{PHL4} , t _{PLH4}	C _L = 50 pF See figure 5	V _{CC} = 2.0 V	9		250	ns
				10, 11		375	
	V _{CC} = 4.5 V		9		50		
			10, 11		75		
	V _{CC} = 6.0 V		9		43		
			10, 11		64		
Propagation delay, time, MR to Qn	t _{PHL5} , t _{PLH5}	C _L = 50 pF See figure 5	V _{CC} = 2.0 V	9		230	ns
				10, 11		345	
	V _{CC} = 4.5 V		9		46		
			10, 11		69		
	V _{CC} = 6.0 V		9		39		
			10, 11		59		
Propagation delay, time, MR to CO	t _{PLH6}	C _L = 50 pF See figure 5	V _{CC} = 2.0 V	9		230	ns
				10, 11		345	
	V _{CC} = 4.5 V		9		46		
			10, 11		69		
	V _{CC} = 6.0 V		9		39		
			10, 11		59		

See footnotes at end of table.

STANDARD MICROCIRCUIT DRAWING DEFENSE SUPPLY CENTER COLUMBUS COLUMBUS, OHIO 43216-5000	SIZE A		86011
		REVISION LEVEL B	SHEET 7

Table I. Electrical performance characteristics - Continued.

Test	Symbol	Test conditions -55°C ≤ T _C ≤ +125°C <u>1/</u> unless otherwise specified		Group A subgroups	Limits		Unit
					Min	Max	
Transition time	t _{THL} , t _{TLH}	C _L = 50 pF See figure 5	V _{CC} = 2.0 V	9		75	ns
				10, 11		110	
	V _{CC} = 4.5 V		9		15		
			10, 11		22		
	V _{CC} = 6.0 V		9		13		
			10, 11		19		

- 1/ For a power supply of 5.0 V ±10% the worst case output voltage (V_{OH} and V_{OL}) occur for HC at 4.5 V. Thus, the 4.5 V values should be used when designing with this supply. Worst case V_{IH} and V_{IL} occur at V_{CC} = 5.5 V and 4.5 V respectively. (The V_{IH} value at V_{CC} = 5.5 V is 3.85 V.) The worst case leakage currents (I_{IN}, I_{CC}, and I_{OZ}) occur for CMOS at the higher voltage and so the 6.0 V values should be used. Power dissipation capacitance (C_{PD}), typically 40 pF, determines the no load dynamic power consumption, P_D = C_{PD} V_{CC}² f + I_{CC} V_{CC}; and the no load dynamic current consumption, I_S = C_{PD} V_{CC} f + I_{CC}.
- 2/ Test not required if applied as a forcing function for V_{OH} or V_{OL}.
- 3/ AC testing at V_{CC} = 2.0 V and V_{CC} = 6.0 V shall be guaranteed, if not tested, to the specified parameters in table I.
- 4/ Transition times (t_{TLH}, t_{THL}) shall be guaranteed, if not tested, to the limits specified in table I.

STANDARD MICROCIRCUIT DRAWING DEFENSE SUPPLY CENTER COLUMBUS COLUMBUS, OHIO 43216-5000	SIZE A		86011
		REVISION LEVEL B	SHEET 8

Device type	01	
Case outline	E	2
Terminal Number	Terminal Symbol	
1	Q5	NC
2	Q1	Q5
3	Q0	Q1
4	Q2	Q0
5	Q6	Q2
6	Q7	NC
7	Q3	Q6
8	GND	Q7
9	Q8	Q3
10	Q4	GND
11	Q9	NC
12	CO	Q8
13	\overline{CE}	Q4
14	CP	Q9
15	MR	CO
16	V _{CC}	NC
17		\overline{CE}
18		CP
19		MR
20		V _{CC}

NC = No connection

Pin description	
Qn (n = 0 to 9)	Data outputs
CO	Carry Out output
\overline{CE}	Clock enable input (active low)
MR	Reset input
CP	Clock pulse input

FIGURE 1. Terminal connections.

STANDARD MICROCIRCUIT DRAWING DEFENSE SUPPLY CENTER COLUMBUS COLUMBUS, OHIO 43216-5000	SIZE A		86011
		REVISION LEVEL B	SHEET 9

CP	$\overline{\text{CE}}$	MR	Output state ^{1/}
L	X	L	No change
X	H	L	No change
X	X	H	0 = H, 1 to 9 = L
↑	L	L	Increments counter
↓	X	L	No change
X	↑	L	No change
H	↓	L	Increments counter

H = High level voltage
 L = Low level voltage
 ↑ = Low-to-high clock transition
 ↓ = High-to-low clock transition
 X = Irrelevant
^{1/} Carry Out = If $n < 5$ CO = H, otherwise CO = L

FIGURE 2. Truth table.

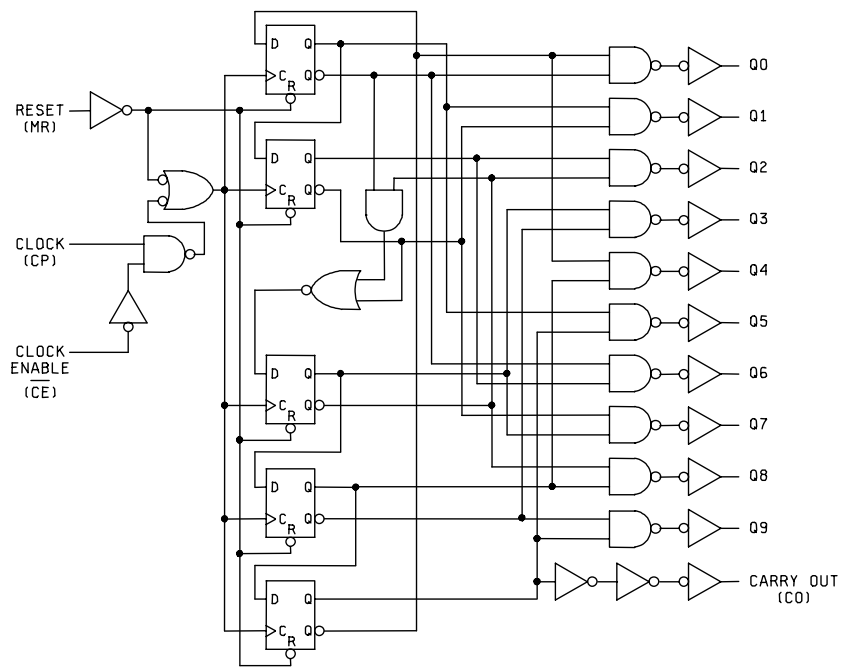

FIGURE 3. Logic diagram.

STANDARD MICROCIRCUIT DRAWING DEFENSE SUPPLY CENTER COLUMBUS COLUMBUS, OHIO 43216-5000	SIZE A	86011
	REVISION LEVEL B	SHEET 10

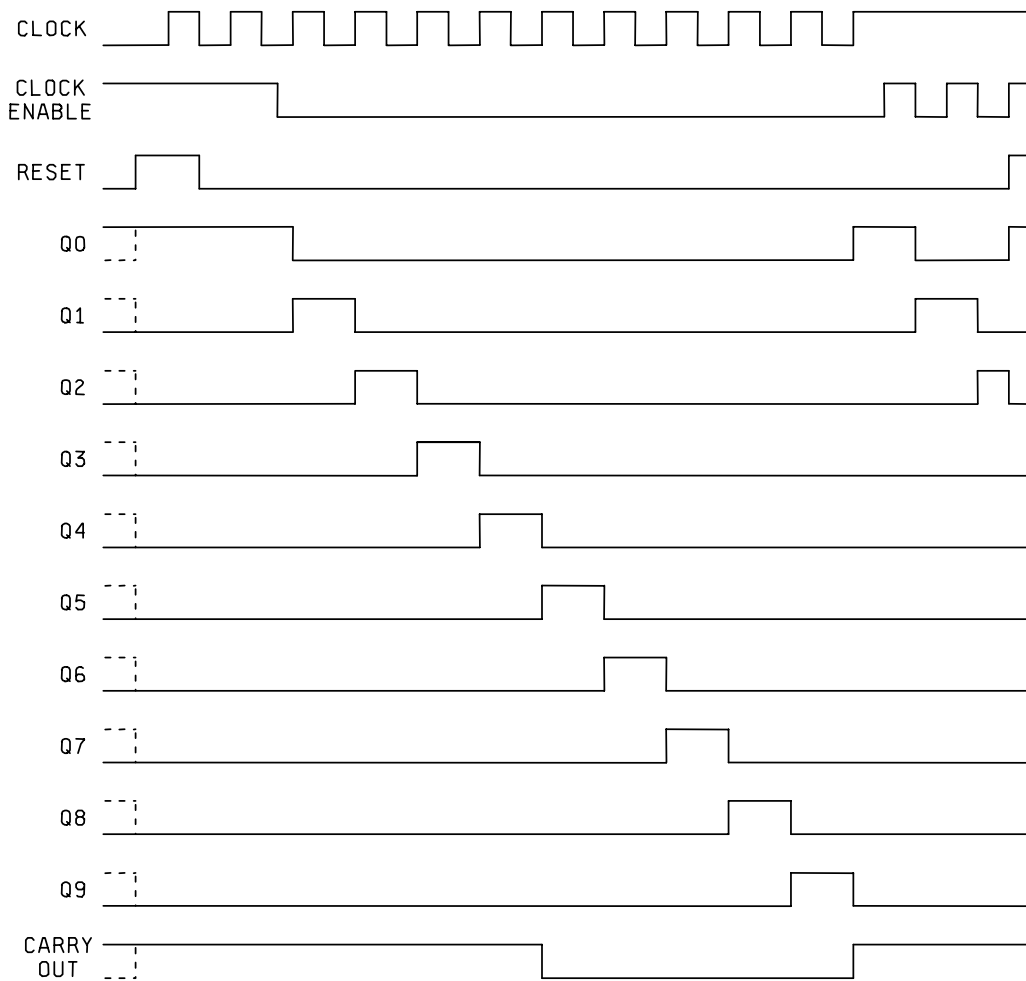
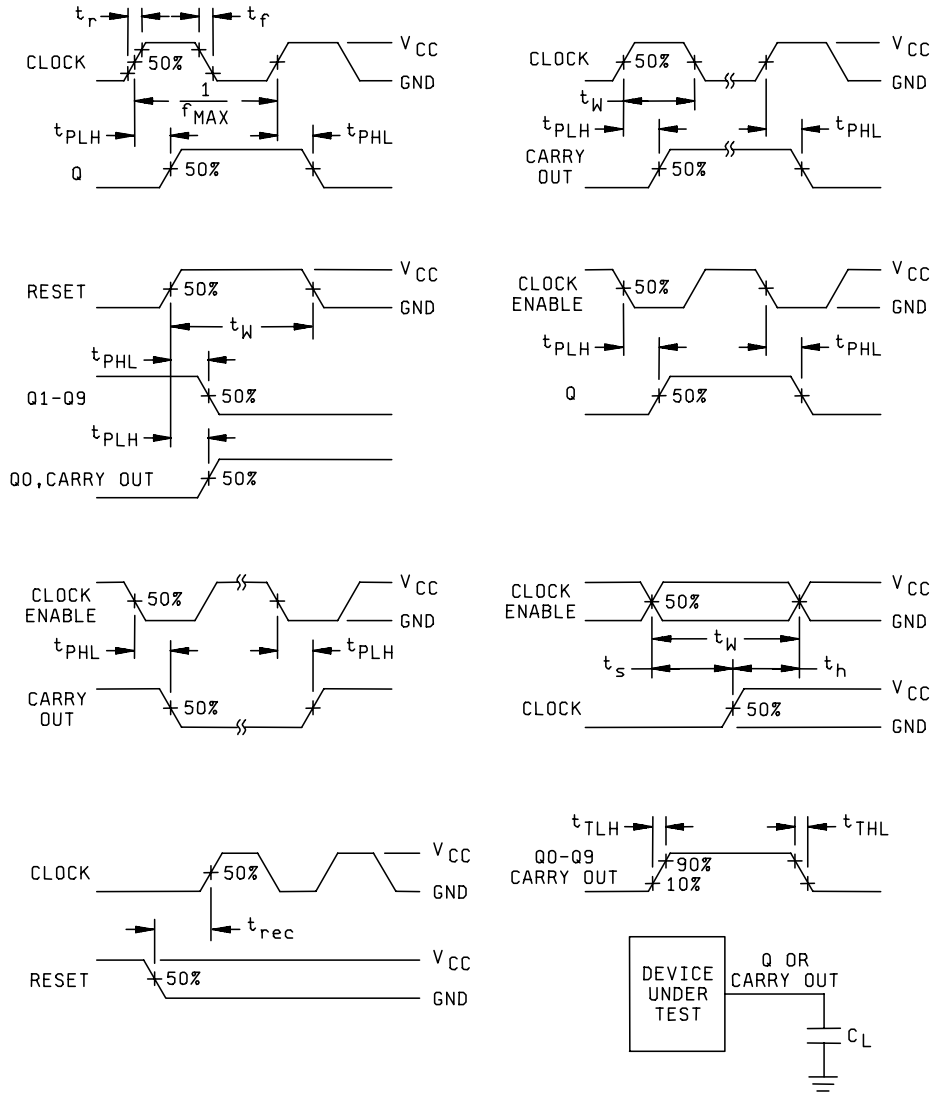

FIGURE 4. Counting sequence.

STANDARD MICROCIRCUIT DRAWING DEFENSE SUPPLY CENTER COLUMBUS COLUMBUS, OHIO 43216-5000	SIZE A		86011
		REVISION LEVEL B	SHEET 11



NOTES:

1. $C_L = 50$ pF minimum or equivalent (includes test jig and probe capacitance).
2. Phase relationships between waveforms were chosen arbitrarily. All input pulses were supplied by generators having the following characteristics: $PRR \leq 1$ MHz, $Z_O = 50 \Omega$, $t_r = 6$ ns, $t_f = 6$ ns.
3. The outputs are measured one at a time with one transition per measurement.

FIGURE 5. Switching waveforms and test circuit.

STANDARD MICROCIRCUIT DRAWING DEFENSE SUPPLY CENTER COLUMBUS COLUMBUS, OHIO 43216-5000	SIZE A		86011
		REVISION LEVEL B	SHEET 12

4. QUALITY ASSURANCE PROVISIONS

4.1 Sampling and inspection. Sampling and inspection procedures shall be in accordance with MIL-PRF-38535, appendix A.

4.2 Screening. Screening shall be in accordance with method 5004 of MIL-STD-883, and shall be conducted on all devices prior to quality conformance inspection. The following additional criteria shall apply:

- a. Burn-in test, method 1015 of MIL-STD-883.
 - (1) Test condition A, B, C, or D. The test circuit shall be maintained by the manufacturer under document revision level control and shall be made available to the preparing or acquiring activity upon request. The test circuit shall specify the inputs, outputs, biases, and power dissipation, as applicable, in accordance with the intent specified in test method 1015 of MIL-STD-883.
 - (2) $T_A = +125^{\circ}\text{C}$, minimum.
- b. Interim and final electrical test parameters shall be as specified in table II herein, except interim electrical parameter tests prior to burn-in are optional at the discretion of the manufacturer.

4.3 Quality conformance inspection. Quality conformance inspection shall be in accordance with method 5005 of MIL-STD-883 including groups A, B, C, and D inspections. The following additional criteria shall apply.

4.3.1 Group A inspection.

- a. Tests shall be as specified in table II herein.
- b. Subgroups 5, 6 and 8 in table I, method 5005 of MIL-STD-883 shall be omitted.
- c. Subgroup 4 (C_{IN} measurement) shall be measured only for the initial test and after process or design changes which may affect input capacitance.
- d. Subgroup 7 shall include verification of the truth table.

4.3.2 Groups C and D inspections.

- a. End-point electrical parameters shall be as specified in table II herein.
- b. Steady-state life test conditions, method 1005 of MIL-STD-883.
 - (1) Test condition A, B, C, and D. The test circuit shall be maintained by the manufacturer under document revision level control and shall be made available to the preparing or acquiring activity upon request. The test circuit shall specify the inputs, outputs, biases, and power dissipation, as applicable, in accordance with the intent specified in test method 1005 of MIL-STD-883.
 - (2) $T_A = +125^{\circ}\text{C}$, minimum.
 - (3) Test duration: 1,000 hours, except as permitted by method 1005 of MIL-STD-883.

STANDARD MICROCIRCUIT DRAWING DEFENSE SUPPLY CENTER COLUMBUS COLUMBUS, OHIO 43216-5000	SIZE A		86011
		REVISION LEVEL B	SHEET 13

TABLE II. Electrical test requirements.

MIL-STD-883 test requirements	Subgroups (in accordance with MIL-STD-883, method 5005, table I)
Interim electrical parameters (method 5004)	---
Final electrical test parameters (method 5004)	1, 2, 9 <u>1/</u>
Group A test requirements (method 5005)	1, 2, 3, 4, 7, 9, 10, 11 <u>2/</u>
Groups C and D end-point electrical parameters (method 5005)	1, 2, 3

1/ PDA applies to subgroup 1.

2/ Subgroups 10 and 11, if not tested, shall be guaranteed to the specified limits in table I.

5. PACKAGING

5.1 Packaging requirements. The requirements for packaging shall be in accordance with MIL-PRF-38535, appendix A.

6. NOTES

6.1 Intended use. Microcircuits conforming to this drawing are intended for use for Government microcircuit applications (original equipment), design applications, and logistics purposes.

6.2 Replaceability. Microcircuits covered by this drawing will replace the same generic device covered by a contractor-prepared specification or drawing.

6.3 Configuration control of SMD's. All proposed changes to existing SMD's will be coordinated with the users of record for the individual documents. This coordination will be accomplished using DD Form 1692, Engineering Change Proposal.

6.4 Record of users. Military and industrial users shall inform Defense Supply Center Columbus when a system application requires configuration control and the applicable SMD. DSCC will maintain a record of users and this list will be used for coordination and distribution of changes to the drawings. Users of drawings covering microelectronics devices (FSC 5962) should contact DSCC-VA, telephone (614) 692-0544.

6.5 Comments. Comments on this drawing should be directed to DSCC-VA, Columbus, Ohio 43216-5000, or telephone (614) 692-0547.

6.6 Approved sources of supply. Approved sources of supply are listed in MIL-HDBK-103 and QML-38535. The vendors listed in MIL-HDBK-103 and QML-38535 have agreed to this drawing and a certificate of compliance (see 3.6 herein) has been submitted to and accepted by DSCC-VA.

STANDARD MICROCIRCUIT DRAWING DEFENSE SUPPLY CENTER COLUMBUS COLUMBUS, OHIO 43216-5000	SIZE A		86011
		REVISION LEVEL B	SHEET 14

STANDARD MICROCIRCUIT DRAWING SOURCE APPROVAL BULLETIN

DATE: 01-11-26

Approved sources of supply for SMD 86011 are listed below for immediate acquisition information only and shall be added to MIL-HDBK-103 and QML-38535 during the next revision. MIL-HDBK-103 and QML-38535 will be revised to include the addition or deletion of sources. The vendors listed below have agreed to this drawing and a certificate of compliance has been submitted to and accepted by DSCC-VA. This bulletin is superseded by the next dated revision of MIL-HDBK-103 and QML-38535.

Standard microcircuit drawing PIN <u>1/</u>	Vendor CAGE number	Vendor similar PIN <u>2/</u>
8601101EA	01295	CD54HC4017F3A
86011012A	<u>3/</u>	54HC4017M/B2CJC

1/ The lead finish shown for each PIN representing a hermetic package is the most readily available from the manufacturer listed for that part. If the desired lead finish is not listed contact the Vendor to determine its availability.

2/ Caution. Do not use this number for item acquisition. Items acquired to this number may not satisfy the performance requirements of this drawing.

3/ Not available from an approved source of supply.

Vendor CAGE number

01295

Vendor name and address

Texas Instruments Incorporated
 13500 N. Central Expressway
 P.O. Box 655303
 Dallas, TX 75265
 Point of contact: 6412 Highway 75 South
 Sherman, TX 75090-0084

The information contained herein is disseminated for convenience only and the Government assumes no liability whatsoever for any inaccuracies in the information bulletin.