

Helping Customers Innovate, Improve & Grow



EX-421

## Description

The EX-421 provides exceptionally low aging rates and tight temperature stabilities in an extremely small package over a wide range of environmental conditions. This EMXO series bridges the gap between current large, high precision OCXO's and smaller TCXO's. The EX-421 Series becomes the most economical choice where there is a need for spectral purity, short and long term stability, along with small size and dramatically reduced power consumption.

## Features

- Low Power Consumption Precision Oscillator
- Fast Warm-up
- Low Phase Noise
- Good Aging
- Small Form Factor
- SMD and Thru-Hole Mounting Option
- RoHS Compliant \*
- Standard Frequencies: 10MHz, 20MHz and 100MHz
- Design/Material Sourcing/Manufacture/Test in MHS,PA COO:USA
- No ITAR Restriction for importing EAR99
- Previous Model Number: EX-620, EX-420 series

## Applications

- Mobile Data Communications
- Military Portable Radio
- Satellite Communications
- Airborne Equipment
- Avionics
- Instrumentation
- Marine/Land Seismic



\* ( Except parts with Sn-Pb Solder Coated Option )

## Performance Specifications

Frequency Stabilities <sup>1</sup>					
Parameter	Min	Typ	Max	Units	Condition
vs. operating temperature range (See temperature & stability table)			±10	ppb	0... +50°C
			±20	ppb	-20... +70°C
			±30	ppb	-40... +85°C
vs. aging / day (See aging table) vs. aging / per year vs. aging / 10 years			±1.0	ppb	after 30 days of operation
			±100	ppb	
			±1	ppm	
Initial Accuracy	-0.2		+0.2	ppm	at time of shipment
vs. supply voltage change	-5		+5	ppb	VS ± 5%
vs. load change	-5		+5	ppb	Load ± 5%
Warm-up Time			45	sec.	to ± 1 ppm of final frequency (1 hour)
			60	sec.	to ± 100 ppb of final frequency (1 hour)
Supply Voltage (Vs)					
Supply voltage (Standard)	4.75	5.0	5.25	VDC	
Supply voltage (Option)	3.14	3.3	3.46	VDC	
Power Consumption			1.5	Watts	during warm-up
			0.25	Watts	steady state @ +25°C / 3.3 Vdc
			0.30	Watts	steady state @ +25°C / 5.0 Vdc

## Performance Specifications

Parameter	Min	Typ	Max	Units	Condition
Signal [Standard]	<b>HCMOS</b>				
Load		15		pF	
Signal Level (Vol)			0.1 Vs	VDC	
Signal Level (Voh)	0.8 Vs 0.8 Vs			VDC VDC	Vs = 3.3 Vdc Vs = 5.0 Vdc
Rise \ Fall Time			5	ns	(10 - 80 %)
Duty cycle	45		55	%	
Signal [Standard]	<b>Sinewave</b>				
Load		50		ohm	
Output Power [Standard]	0		+4	dBm	50 Ohm load
Output Power [Option]	+3		+7	dBm	50 Ohm load
Harmonics			-30	dBc	50 Ohm load
<b>Frequency Tuning (EFC)</b>					
Reference Voltage (Vref)	2.7 4.2		2.9 4.4	Vdc Vdc	Vs = 3.3 Vdc Vs = 5.0 Vdc
Tuning Voltage	0		+Vref	VDC	
Tuning Range	See tuning range table				
Tuning Slope	Positive				
<b>Additional Parameters</b>					
Phase Noise (10 MHz)		-90 -125 -145 -160 -165		dBc/Hz dBc/Hz dBc/Hz dBc/Hz dBc/Hz	1 Hz 10 Hz 100 KHz 1 KHz 10 KHz
Phase Noise (100 MHz)		-95 -125 -150 -160 -165		dBc/Hz dBc/Hz dBc/Hz dBc/Hz dBc/Hz	10 Hz 100 Hz 1 KHz 10 KHz 100 KHz
Allan Deviation (10 MHz)			0.02	ppb	Tau = 1 sec
Acceleration Sensitivity			1.0	ppb/g	Total Gamma
Weight			5	g	
<b>Absolute Maximum Ratings</b>					
Supply Voltage			5.5	VDC	
Output Load			50	pF	
Operable temperature range	-55		+85	°C	
Storage temperature range	-55		+85	°C	

Vibration Sine	MIL-STD-202, Method 204, Condition G (30g peak, 10Hz-2000Hz)
Vibration Random	MIL-STD-202, Method 214, Condition I-H (30g RMS, 10Hz-2000Hz)
Shock	MIL-STD-202, Method 213, Condition E (1000 g, 0.5ms, 1/2 sine)
Solderability	MIL-STD-883, Method 2003

## Surface Mount

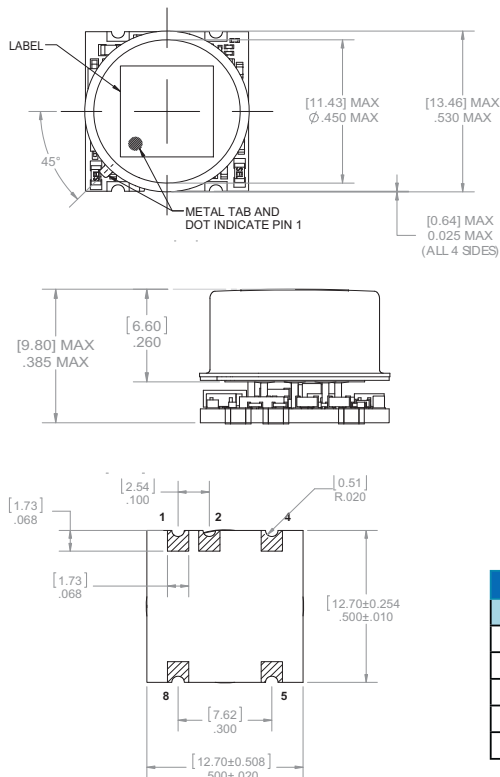

## Thru-hole

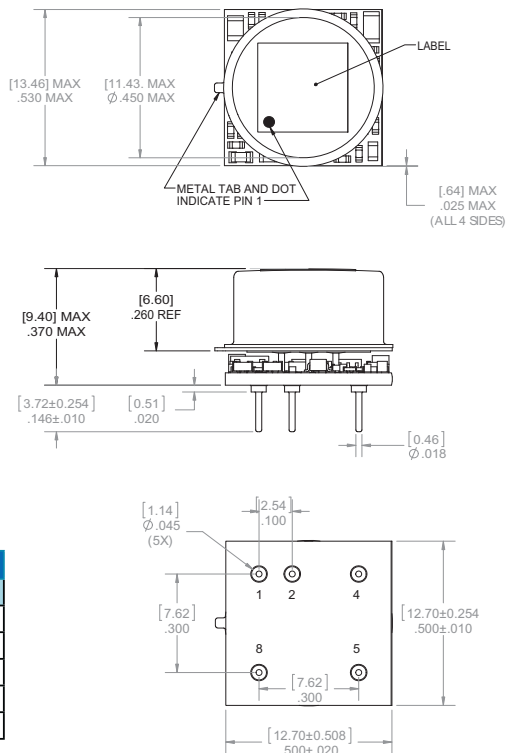

Pin Connections		
Pin	EFC OPTIONS	FIX FREQ. OPTIONS
1	EFC Input	No Connection
2	Vref Output	No Connection
4	Ground (Case)	Ground (Case)
5	RF Output	RF Output
8	Supply Voltage Input	Supply Voltage Input

## Standard Shipping Method (surface mount)

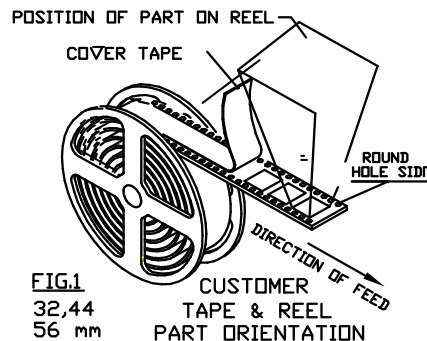
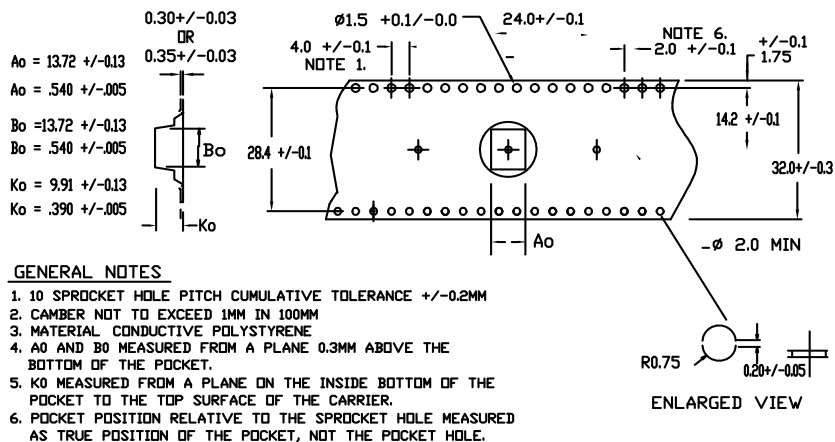

## Standard Shipping Method (thru-hole)

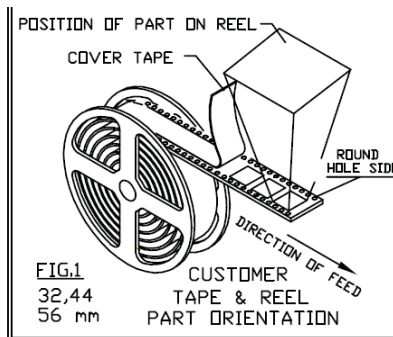
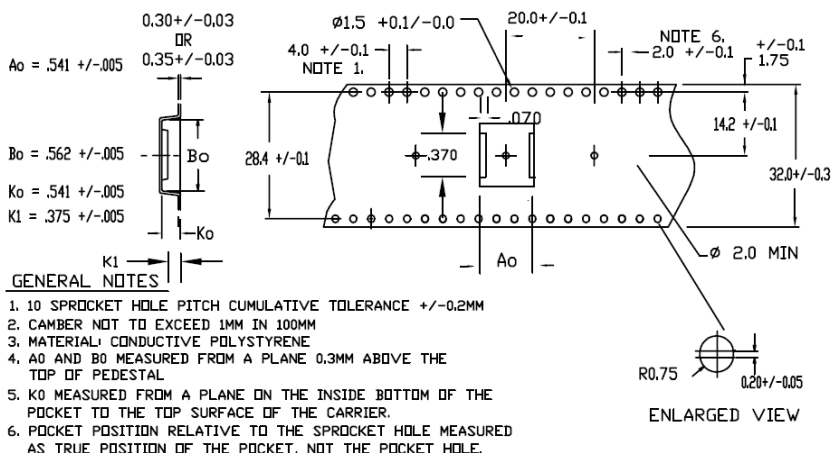

## Recommended Reflow Profiles for Pb-Free & Sn-Pb

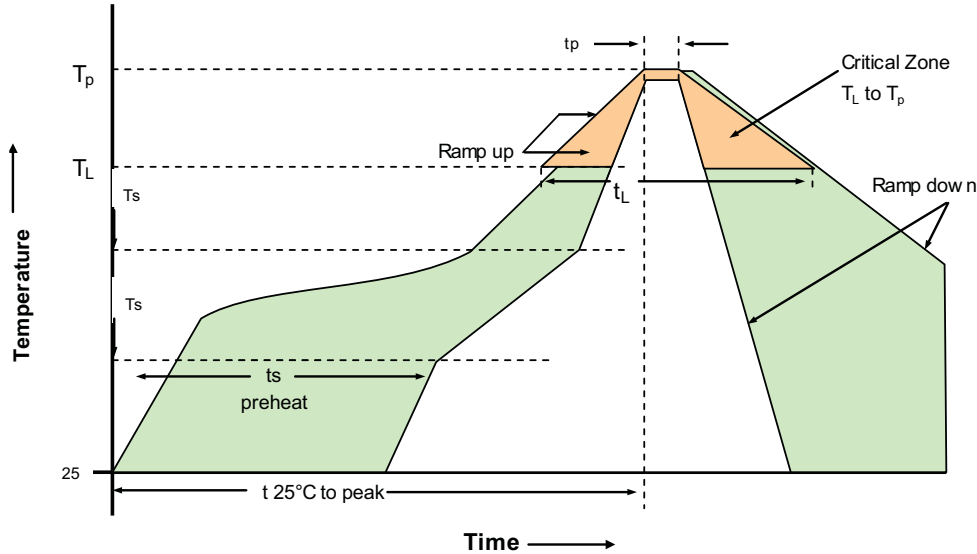

### 230°C Reflow Profile

Profile Feature	Sn-Pb Assembly	Profile Feature	Sn-Pb Assembly
Average ramp-up rate (TL to TP)	3°C/seconds max.	Time 25°C to Peak Temperature	4 minutes max.
Preheat - Temperature min T <sub>min</sub> - Temperature Min T <sub>max</sub> - Time (min to max) (ts)	135°C 155°C 60-90 seconds	Time maintained above - Temperature (TL) - Time (tL)	183°C 45-60 seconds
T <sub>max</sub> to TL -Ramp-up Rate	3°C/seconds max.		
Time maintained above - Temperature (TL) - Time (TL)	183°C 40-60 seconds	Time within 5°C of actual Peak Temperature (tp)	10-20 seconds max.
Peak Temperature (Tp)	max 230°C	Ramp-down Rate	6°C/seconds max.

**Note:** All temperatures refer to topside of the package, measured on the package body surface.

### 260°C Reflow Profile

Profile Feature	Pb-Free Assembly	Profile Feature	Pb-Free Assembly
Average ramp-up rate (TL to TP)	3°C/seconds max.	Time 25°C to Peak Temperature	8 minutes max.
Preheat - Temperature min T <sub>min</sub> - Temperature min T <sub>max</sub> - Time (min to max) (ts)	150°C 200°C 60-180 seconds	Time maintained above - Temperature (TL) - Time (tL)	217°C 60-150 seconds
T <sub>max</sub> to TL -Ramp-up Rate	3°C/seconds max.		
Time maintained above - Temperature (TL) - Time (TL)	217°C 60-150 seconds	Time within 5°C of actual Peak Temperature (tp)	20-40 seconds max.
Peak Temperature (Tp)	max 260°C	Ramp-down Rate	6°C/seconds max.

**Note:** All temperatures refer to topside of the package, measured on the package body surface.

# Ordering Information

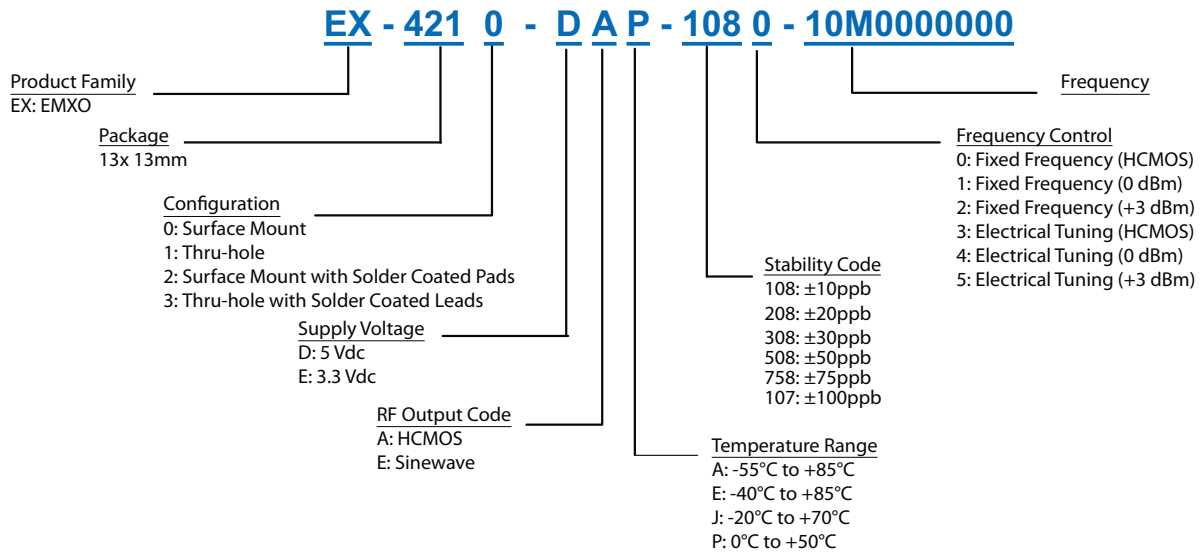

Temperature Range and Stability Table				
( Temperature Stability Reference to $(F_{max}-F_{min})/2$ )				
Stability/Temperature	A: -55°C to +85°C	E: -40°C to +85°C	J: -20°C to +70°C	P: 0°C to +50°C
108 (+/-10ppb)				10-20MHz
208 (+/-20ppb)			10-20MHz	10-20MHz
308 (+/-30ppb)	10-20MHz	10-20MHz	10-20MHz	10-20MHz
508 (+/-50ppb)	10-50MHz	10-50MHz	10-50MHz	10-50MHz
758 (+/-75ppb)	10-80MHz	10-100MHz	10-100MHz	10-100MHz
107 (+/-100ppb)	10-100MHz			

Aging Table			
Frequency Range	Daily Rate (ppb/day)	Yearly Rate (ppb/year)	Tuning Range (ppm)
10MHz to 15MHz	± 1	± 100	± 1
>15MHz to 100MHz	± 2	± 200	± 2

**Notes:**

- Contact factory for improved stabilities or additional product options. Not all options and codes are available at all frequencies.
- Unless other stated all values are valid after warm-up time and refer to typical conditions for supply voltage, frequency control voltage, load, temperature (25°C).
- Phase noise degrades with increasing output frequency.
- Subject to technical modification.
- Contact factory for availability.

## For Additional Information, Please Contact

**USA:**

Vectron International  
267 Lowell Road, Unit 102  
Hudson, NH 03051  
Tel: 1.888.328.7661  
Fax: 1.888.329.8328

**Europe:**

Vectron International  
Landstrasse, D-74924  
Neckarbischofsheim, Germany  
Tel: +49 (0) 3328.4784.17  
Fax: +49 (0) 3328.4784.30

**Asia:**

Vectron International  
68 Yin Cheng Road(C), 22nd Floor  
One LuJiaZui  
Pudog, Shanghai 200120, China  
Tel: 86.21.6194.6886  
Fax: 86.21.6194.6699

**Disclaimer**

Vectron International reserves the right to make changes to the product(s) and or information contained herein without notice. No liability is assumed as a result of their use or application. No rights under any patent accompany the sale of any such product(s) or information.