

R Series Tantalum Chip Capacitors

DIMENSIONS [mm]

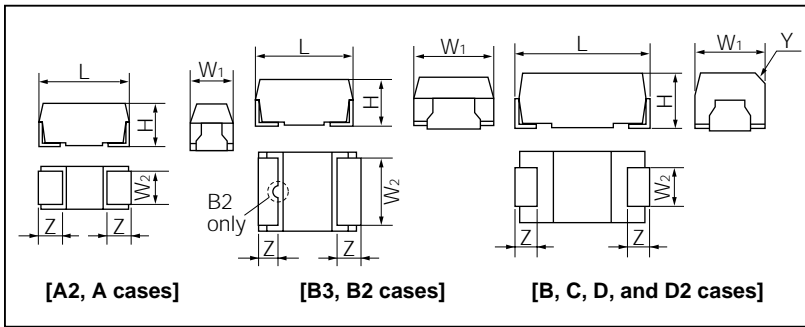

(Unit: mm)

Case Code	EIA code	L	W ₁	W ₂	H	Z	Y
A2 (U)	3216L	3.2 ± 0.2	1.6 ± 0.2	1.2 ± 0.1	1.1 ± 0.1	0.8 ± 0.2	
A	3216H	3.2 ± 0.2	1.6 ± 0.2	1.2 ± 0.1	1.6 ± 0.2	0.8 ± 0.2	
B3 (W)	—	3.5 ± 0.2	2.8 ± 0.2	2.2 ± 0.1	1.1 ± 0.1	0.8 ± 0.2	
B2 (S)	3528	3.5 ± 0.2	2.8 ± 0.2	2.3 ± 0.1	1.9 ± 0.2	0.8 ± 0.2	
B	—	4.7 ± 0.2	2.6 ± 0.2	1.4 ± 0.1	2.1 ± 0.2	0.8 ± 0.2	0.4 C
C	6032	6.0 ± 0.2	3.2 ± 0.2	2.2 ± 0.1	2.5 ± 0.2	1.3 ± 0.2	0.4 C
D2 (T)	5846	5.8 ± 0.2	4.6 ± 0.2	2.4 ± 0.1	3.2 ± 0.2	1.3 ± 0.2	
D	7343	7.3 ± 0.2	4.3 ± 0.2	2.4 ± 0.1	2.8 ± 0.2	1.3 ± 0.2	0.5 C

(STANDARD C-V VALUE REFERENCE BY CASE CODE)

DC Rated Voltage (Vdc) / μF	4	6.3	10	16	20	25	35	50
0.47						A	B2, B	B2
0.68					A		B2, B	C
1.0				A			B2, B	C
1.5			A	A		B2, B	C	C
2.2		A	A		B2, B		C	D
3.3	A	A		B2, B		C	C, D	D, D2
4.7	A		B2, B		C	C	D2, D	D
6.8		B2, B		C	C	D2, D	D2, D	
10	B2, B		C	C	D2, D	D2, D		
15		C	C	D2, D	D2, D			
22	C	C	D2, D	D2, D				
33	C	D2, D	D2, D					
47	D2, D	D2, D						
68	D2, D							

PERFORMANCE CHARACTERISTICS

Operating temperature range

–55 to +125°C with proper voltage

derating as shown in the following table.

DC working voltage and surge voltage

Rated voltage	2.5	4	6.3	10	16	20	25	35	50	V
Working	at 85°C	2.5	4	6.3	10	16	20	25	35	50
	at 125°C	1.6	2.5	4	6.3	10	13	16	22	32
Surge	at 85°C	3.3	5.2	8	13	20	26	33	46	65

Capacitance (at 20°C, 120 Hz)

Range: 0.47 μF to 680 μF

Tolerance: ± 20%, (±10%)

Capacitance change with temperature

Not to exceed –12% at –55°C, +12% at

85°C, and +15% at 125°C

Tangent of loss angle (at 20°C, 120 Hz)

(Standard)

0.047 μF to 4.7 μF: less than 0.04

6.8 μF to 68 μF: less than 0.06

(Extended) (1)

2.5 Vdc to 10 Vdc: less than 0.08

16 Vdc to 35 Vdc: less than 0.06

DC leakage current (at 20°C)

0.01 C·V(2) μA or 0.5 μA, whichever is greater

Damp heat (90 to 95% RH at 40°C, 56 days (1344 h))

Capacitance change: ±5% (±12%) (3)

Tangent of loss angle: 150% of initial

requirements

DC leakage current: initial requirements

Endurance (at 85°C, DC rated voltage, 2000 h)

Capacitance change: ±10% (±12%) (3)

Tangent of loss angle: initial requirements

DC leakage current: 125% of

initial requirements

Resistance to soldering heat

(solder reflow at 260°C, 10 s.

or solder dip at 260°C, 5 s.)

Capacitance change: +5% (+12%) (3)

Leakage current: initial requirements

Tangent of loss angle: initial requirements

NEC obtained IEC Qualification Approval on R

Series Standard Ratings in September 1987.

1. Refer to standard ratings for tangent of loss angle of the following items:

2.5 V/15 μF, 22 μF, 4 V/10 μF, 15 μF, 22 μF, 6.3 V/15 μF products in A2 case.

2.5 V/47 μF, 68 μF, 4 V/33 μF, 47 μF, 6.3 V/22 μF, 33 μF, 47 μF, 10 V/22 μF, 16 V/10 μF products in A case.

2.5 V/47 μF, 68 μF, 100 μF, 4 V/33 μF, 47 μF, 68 μF, 100 μF, 6.3 V/22 μF, 33 μF, 47 μF, 10 V/15 μF, 22 μF, 16 V/10 μF products in B3 case.

2.5 V/150 μF, 220 μF, 4 V/100 μF, 150 μF, 6.3 V/68 μF, 100 μF products in B2 case.

2.5 V/220 μF, 470 μF, 4 V/150 μF, 220 μF, 330 μF, 6.3 V/100 μF, 150 μF, 220 μF products in C case.

2.5 V/330 μF, 4 V/220 μF, 6.3 V/150 μF, 10 V/100 μF products in D2 case.

2.5 V/470 μF, 4 V/330 μF, 470 μF, 680 μF, 6.3 V/220 μF, 330 μF, 470 μF, 10 V/150 μF, 220 μF, 16 V/100 μF products in D case.

2. Product of capacitance in μF and voltage in V.

3. Capacitance change of ± 12% applies to

2.5 V/4.7 μF to 22 μF, 4 V/4.7 μF to 22 μF, 6.3 V/3.3 μF to 15 μF, 10 V/2.2 μF to 10 μF, 16 V/1.5 μF, 2.2 μF, 20 V/1 μF, 1.5 μF products in A2 case;

2.5 V/15 μF to 68 μF, 4 V/10 μF to 47 μF, 6.3 V/6.8 μF to 47 μF, 10 V/4.7 μF to 22 μF, 16 V/3.3 μF to 6.8 μF, 20 V/2.2 μF to 4.7 μF, 25 V/1.5 μF, 2.2 μF, 35 V/1 μF, 1.5 μF products in A case;

2.5 V/33 μF to 150 μF, 4 V/100 μF, 6.3 V/68 μF, 100 μF, 10 V/4.7 μF products in B2 case;

(R SERIES EXTENDED C-V VALUE REFERENCE BY CASE CODE)

DC Rated Voltage μF	2.5	4	6.3	10	16	20	25	35
0.47						A2		A
0.68					A2	A2	A	A
1.0				A2	A2	A2, A	A	A
1.5			A2	A2	A2	A2, A	A	A, B2, B
2.2		A2	A2	A2	A2, A	A	A, B2	B2, B
3.3		A2	A2	A2, A	A	A, B2	B2, B	B2
4.7	A2	A2	A2, A	A2, A	A, B2	A, B2, B	B2	C
6.8	A2	A2, A	A2, A	A, B2	A, B3, B2, B	B2	C	C
10	A2	A2, A	A2, A, B2	A2, A, B3, B2, B	A, B3, B2	B2, C	C	D2, D
15	A2, A	A2, A, B2	A2, A, B3, B2, B	B3, B2	B2, C	C	D2, D	D
22	A2, A	A2, A, B3, B2, B	A, B3, B2	A, B3, B2, C	B2, C	C, D2, D	D	
33	A, B3, B2	A, B3, B2	A, B3, B2, C	B2, C	C, D2, D	D2, D		
47	A, B3, B2	A, B3, B2, C	A, B3, B2, C	B2, C, D2, D	C, D2, D	D		
68	A, B3, B2	B3, B2, C	B2, C, D2, D	C, D2, D	D			
100	B3, B2	B3, B2, C, D2, D	B2, C, D2, D	C, D2, D	D			
150	B2	C, D2, D	C, D2, D	D				
220	B2, C	C, D2, D	C, D	D				
330	D2	C, D	D					
470	C, D	D	D					
680		D						

2.5 V/220 μF, 470 μF, 4 V/150 μF to 330 μF, 6.3 V/100 μF, 10 V/68 μF, 16 V/47 μF products in C case;
 2.5 V/330 μF, 4 V/220 μF, 6.3 V/150 μF, 10 V/100 μF products in D2 case;
 2.5 V/470 μF, 4 V/330 μF, 470 μF, 680 μF, 6.3 V/220 μF, 330 μF, 470 μF, 10 V/150 μF, 220 μF, 16 V/100 μF products in D case.
 Capacitance change of ±15% applies to all products with the B3 case.

See pages 25 and 26 for taping specifications.

MARKINGS

The standard marking shows capacitance, DC rated voltage, and polarity.

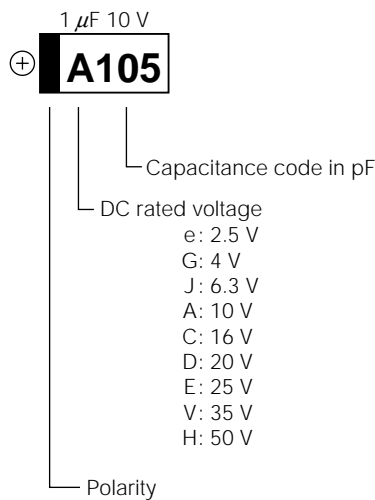

[A2, A cases]

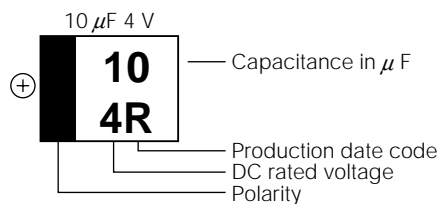

[B3, B2, and D2 cases]

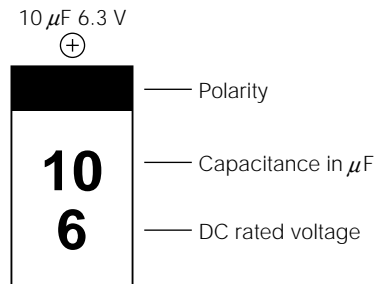

[B case]

[Marking of production date code]

y \ M	Jan.	Feb.	Mar.	Apr.	May	Jun.	Jul.	Aug.	Sep.	Oct.	Nov.	Dec.
2001	A	B	C	D	E	F	G	H	J	K	L	M
2002	N	P	Q	R	S	T	U	V	W	X	Y	Z
2003	a	b	c	d	e	f	g	h	j	k	l	m
2004	n	p	q	r	s	t	u	v	w	x	y	z

Note: Production date code will repeat beginning in 2005.

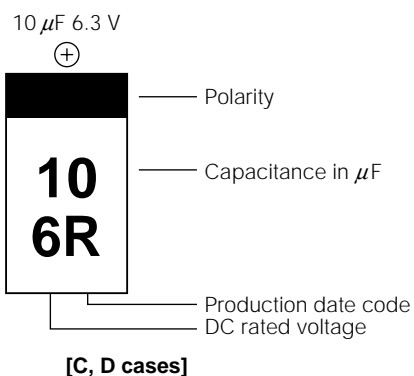

PART NUMBER SYSTEM

Bulk

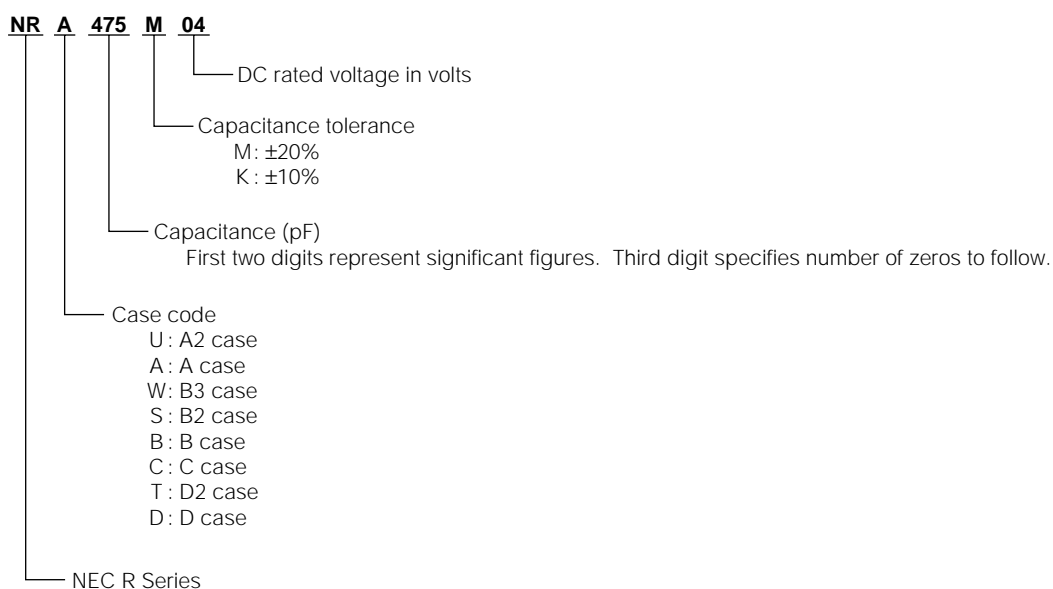

Tape and Reel

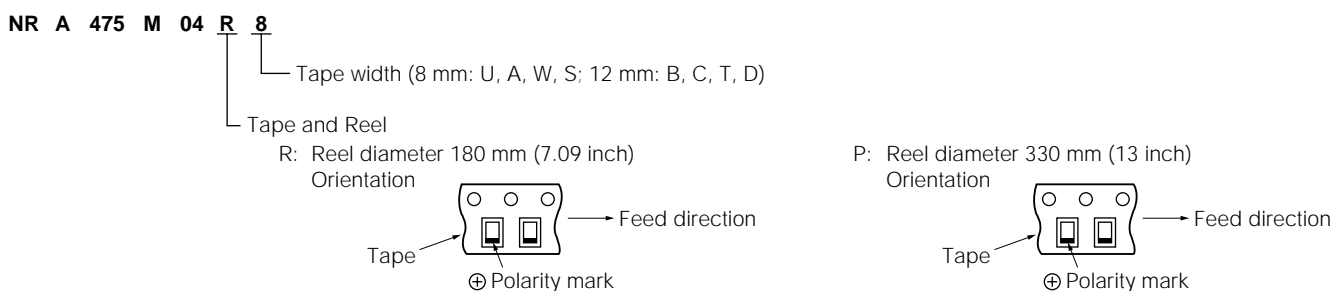

STANDARD RATINGS

Part Number	Capacitance (μF)	Case Code	DC Leakage Current (μA)	Tangent of Loss Angle
50 V Rating				
NRS474M50	0.47	B2	0.5	0.04
NRC684M50	0.68	C	0.5	0.04
NRC105M50	1	C	0.5	0.04
NRC155M50	1.5	C	0.7	0.04
NRD225M50	2.2	D	1.1	0.04
NRD335M50	3.3	D	1.6	0.04
NRT335M50	3.3	D2	1.6	0.04
NRD475M50	4.7	D	2.3	0.04
35 V Rating				
NRS474M35	0.47	B2	0.5	0.04
NRB474M35	0.47	B	0.5	0.04
NRS684M35	0.68	B2	0.5	0.04
NRB684M35	0.68	B	0.5	0.04
NRS105M35	1	B2	0.5	0.04
NRB105M35	1	B	0.5	0.04
NRC155M35	1.5	C	0.5	0.04
NRC225M35	2.2	C	0.7	0.04
NRC335M35	3.3	C	1.2	0.04
NRD335M35	3.3	D	1.2	0.04
NRT475M35	4.7	D2	1.6	0.04
NRD475M35	4.7	D	1.6	0.04
NRT685M35	6.8	D2	2.3	0.06
NRD685M35	6.8	D	2.3	0.06
25 V Rating				
NRA474M25	0.47	A	0.5	0.04
NRS155M25	1.5	B2	0.5	0.04
NRB155M25	1.5	B	0.5	0.04
NRC335M25	3.3	C	0.8	0.04
NRC475M25	4.7	C	1.1	0.04
NRT685M25	6.8	D2	1.7	0.06
NRD685M25	6.8	D	1.7	0.06
NRT106M25	10	D2	2.5	0.06
NRD106M25	10	D	2.5	0.06
20 V Rating				
NRA684M20	0.68	A	0.5	0.04
NRS225M20	2.2	B2	0.5	0.04
NRB225M20	2.2	B	0.5	0.04
NRC475M20	4.7	C	0.9	0.04
NRC685M20	6.8	C	1.4	0.06
NRT106M20	10	D2	2.0	0.06
NRD106M20	10	D	2.0	0.06
NRT156M20	15	D2	3.0	0.06
NRD156M20	15	D	3.0	0.06

Part Number	Capacitance (μF)	Case Code	DC Leakage Current (μA)	Tangent of Loss Angle
16 V Rating				
NRA105M16	1	A	0.5	0.04
NRA155M16	1.5	A	0.5	0.04
NRS335M16	3.3	B2	0.5	0.04
NRB335M16	3.3	B	0.5	0.04
NRC685M16	6.8	C	1.0	0.06
NRC106M16	10	C	1.6	0.06
NRT156M16	15	D2	2.4	0.06
NRD156M16	15	D	2.4	0.06
NRT226M16	22	D2	3.5	0.06
NRD226M16	22	D	3.5	0.06
10 V Rating				
NRA155M10	1.5	A	0.5	0.04
NRA225M10	2.2	A	0.5	0.04
NRS475M10	4.7	B2	0.5	0.04
NRB475M10	4.7	B	0.5	0.04
NRC106M10	10	C	1.0	0.06
NRC156M10	15	C	1.5	0.06
NRT226M10	22	D2	2.2	0.06
NRD226M10	22	D	2.2	0.06
NRT336M10	33	D2	3.3	0.06
NRD336M10	33	D	3.3	0.06
6.3 V Rating				
NRA225M06	2.2	A	0.5	0.04
NRA335M06	3.3	A	0.5	0.04
NRS685M06	6.8	B2	0.5	0.06
NRB685M06	6.8	B	0.5	0.06
NRC156M06	15	C	0.9	0.06
NRC226M06	22	C	1.4	0.06
NRT336M06	33	D2	2.0	0.06
NRD336M06	33	D	2.0	0.06
NRT476M06	47	D2	3.0	0.06
NRD476M06	47	D	3.0	0.06
4 V Rating				
NRA335M04	3.3	A	0.5	0.04
NRA475M04	4.7	A	0.5	0.04
NRS106M04	10	B2	0.5	0.06
NRB106M04	10	B	0.5	0.06
NRC226M04	22	C	0.8	0.06
NRC336M04	33	C	1.3	0.06
NRT476M04	47	D2	1.9	0.06
NRD476M04	47	D	1.9	0.06
NRT686M04	68	D2	2.7	0.06
NRD686M04	68	D	2.7	0.06

Notes:

Part numbers are for ±20% capacitance tolerance.

EXTENDED CHIPS STANDARD RATINGS

Part Number	Capacitance (μF)	Case Code	DC Leakage Current (μA)	Tangent of Loss Angle
35 V Rating				
NRA474M35	0.47	A	0.5	0.06
NRA684M35	0.68	A	0.5	0.06
NRA105M35	1	A	0.5	0.06
NRA155M35	1.5	A	0.5	0.06
NRS155M35	1.5	B2	0.5	0.06
NRB155M35	1.5	B	0.5	0.06
NRS225M35	2.2	B2	0.7	0.06
NRB225M35	2.2	B	0.7	0.06
NRS335M35	3.3	B2	1.1	0.06
NRC475M35	4.7	C	1.6	0.06
NRC685M35	6.8	C	2.3	0.06
NRT106M35	10	D2	3.5	0.06
NRD106M35	10	D	3.5	0.06
NRD156M35	15	D	5.2	0.06
25 V Rating				
NRA684M25	0.68	A	0.5	0.06
NRA105M25	1	A	0.5	0.06
NRA155M25	1.5	A	0.5	0.06
NRA225M25	2.2	A	0.5	0.06
NRS225M25	2.2	B2	0.5	0.06
NRS335M25	3.3	B2	0.8	0.06
NRB335M25	3.3	B	0.8	0.06
NRS475M25	4.7	B2	1.1	0.06
NRC685M25	6.8	C	1.7	0.06
NRC106M25	10	C	2.5	0.06
NRT156M25	15	D2	3.7	0.06
NRD156M25	15	D	3.7	0.06
NRD226M25	22	D	5.5	0.06
20 V Rating				
NRU474M20	0.47	A2	0.5	0.06
NRU684M20	0.68	A2	0.5	0.06
NRU105M20	1	A2	0.5	0.06
NRA105M20	1	A	0.5	0.06
NRU155M20	1.5	A2	0.5	0.06
NRA155M20	1.5	A	0.5	0.06
NRA225M20	2.2	A	0.5	0.06
NRA335M20	3.3	A	0.6	0.06
NRS335M20	3.3	B2	0.6	0.06
NRA475M20	4.7	A	0.9	0.06
NRS475M20	4.7	B2	0.9	0.06
NRB475M20	4.7	B	0.9	0.06
NRS685M20	6.8	B2	1.4	0.06
NRS106M20	10	B2	2.0	0.06
NRC106M20	10	C	2.0	0.06
NRC156M20	15	C	3.0	0.06
NRC226M20	22	C	4.4	0.06
NRT226M20	22	D2	4.4	0.06
NRD226M20	22	D	4.4	0.06
NRT336M20	33	D2	6.6	0.06
NRD336M20	33	D	6.6	0.06
NRD476M20	47	D	9.4	0.06

Notes:Part numbers are for $\pm 20\%$ capacitance tolerance.

Part Number	Capacitance (μF)	Case Code	DC Leakage Current (μA)	Tangent of Loss Angle
16 V Rating				
NRU684M16	0.68	A2	0.5	0.06
NRU105M16	1	A2	0.5	0.06
NRU155M16	1.5	A2	0.5	0.06
NRU225M16	2.2	A2	0.5	0.06
NRA225M16	2.2	A	0.5	0.06
NRA335M16	3.3	A	0.5	0.06
NRA475M16	4.7	A	0.7	0.06
NRS475M16	4.7	B2	0.7	0.06
NRA685M16	6.8	A	1.0	0.06
NRW685M16	6.8	B3	1.0	0.06
NRS685M16	6.8	B2	1.0	0.06
NRB685M16	6.8	B	1.0	0.06
NRA106M16	10	A	1.6	0.08
NRW106M16	10	B3	1.6	0.08
NRS106M16	10	B2	1.6	0.06
NRS156M16	15	B2	2.4	0.06
NRC156M16	15	C	2.4	0.06
NRS226M16	22	B2	3.5	0.06
NRC226M16	22	C	3.5	0.06
NRC336M16	33	C	5.2	0.06
NRT336M16	33	D2	5.2	0.06
NRD336M16	33	D	5.2	0.06
NRC476M16	47	C	7.5	0.06
NRT476M16	47	D2	7.5	0.06
NRD476M16	47	D	7.5	0.06
NRD686M16	68	D	10.8	0.06
NRD107M16	100	D	16	0.10
10 V Rating				
NRU105M10	1	A2	0.5	0.08
NRU155M10	1.5	A2	0.5	0.08
NRU225M10	2.2	A2	0.5	0.08
NRU335M10	3.3	A2	0.5	0.08
NRA335M10	3.3	A	0.5	0.08
NRU475M10	4.7	A2	0.5	0.08
NRA475M10	4.7	A	0.5	0.08
NRA685M10	6.8	A	0.6	0.08
NRS685M10	6.8	B2	0.6	0.08
NRU106M10	10	A2	1.0	0.08
NRA106M10	10	A	1.0	0.08
NRW106M10	10	B3	1.0	0.08
NRS106M10	10	B2	1.0	0.08
NRB106M10	10	B	1.0	0.08
NRW156M10	15	B3	1.5	0.06
NRS156M10	15	B2	1.5	0.08
NRA226M10	22	A	2.2	0.12
NRW226M10	22	B3	2.2	0.12
NRS226M10	22	B2	2.2	0.08
NRC226M10	22	C	2.2	0.08
NRS336M10	33	B2	3.3	0.08
NRC336M10	33	C	3.3	0.08
NRS476M10	47	B2	4.7	0.08
NRC476M10	47	C	4.7	0.08
NRT476M10	47	D2	4.7	0.08
NRD476M10	47	D	4.7	0.08
NRC686M10	68	C	6.8	0.08
NRT686M10	68	D2	6.8	0.08
NRD686M10	68	D	6.8	0.08
NRT107M10	100	D2	10	0.10
NRD107M10	100	D	10	0.08
NRD157M10	150	D	15	0.10
NRD227M10	220	D	22	0.12

Part Number	Capacitance (μF)	Case Code	DC Leakage Current (μA)	Tangent of Loss Angle
6.3 V Rating				
NRU155M06	1.5	A2	0.5	0.08
NRU225M06	2.2	A2	0.5	0.08
NRU335M06	3.3	A2	0.5	0.08
NRU475M06	4.7	A2	0.5	0.08
NRA475M06	4.7	A	0.5	0.08
NRU155M06	1.5	A2	0.5	0.08
NRU225M06	2.2	A2	0.5	0.08
NRU335M06	3.3	A2	0.5	0.08
NRU475M06	4.7	A2	0.5	0.08
NRA475M06	4.7	A	0.5	0.08
NRU685M06	6.8	A2	0.5	0.08
NRA685M06	6.8	A	0.5	0.08
NRU106M06	10	A2	0.6	0.08
NRA106M06	10	A	0.6	0.08
NRS106M06	10	B2	0.6	0.08
NRU156M06	15	A2	0.9	0.12
NRA156M06	15	A	0.9	0.08
NRW156M06	15	B3	0.9	0.08
NRS156M06	15	B2	0.9	0.08
NRB156M06	15	B	0.9	0.08
NRA226M06	22	A	1.4	0.10
NRW226M06	22	B3	1.3	0.12
NRS226M06	22	B2	1.3	0.08
NRA336M06	33	A	2.0	0.12
NRW336M06	33	B3	2.0	0.20
NRS336M06	33	B2	2.0	0.08
NRC336M06	33	C	2.0	0.08
NRA476M06	47	A	3.0	0.12
NRW476M06	47	B3	2.9	0.12
NRS476M06	47	B2	3.0	0.08
NRC476M06	47	C	3.0	0.08
NRS686M06	68	B2	4.2	0.10
NRC686M06	68	C	4.2	0.08
NRT686M06	68	D2	4.2	0.08
NRD686M06	68	D	4.2	0.08
NRS107M06	100	B2	6.3	0.12
NRC107M06	100	C	6.3	0.08
NRT107M06	100	D2	6.3	0.08
NRD107M06	100	D	6.3	0.08
NRC157M06	150	C	9.4	0.10
NRT157M06	150	D2	9.4	0.10
NRD157M06	150	D	9.4	0.08
NRC227M06	220	C	13.8	0.14
NRD227M06	220	D	13.8	0.12
NRD337M06	330	D	20.7	0.14
NRD477M06	470	D	29.7	0.20
4 V Rating				
NRU225M04	2.2	A2	0.5	0.08
NRU335M04	3.3	A2	0.5	0.08
NRU475M04	4.7	A2	0.5	0.08
NRU685M04	6.8	A2	0.5	0.08
NRA685M04	6.8	A	0.5	0.08
NRU106M04	10	A2	0.5	0.12
NRA106M04	10	A	0.5	0.08
NRU156M04	15	A2	0.6	0.12
NRA156M04	15	A	0.6	0.08
NRS156M04	15	B2	0.6	0.08
NRU226M04	22	A2	0.8	0.12
NRA226M04	22	A	0.8	0.06
NRW226M04	22	B3	0.8	0.08
NRS226M04	22	B2	0.8	0.08
NRB226M04	22	B	0.8	0.08
NRA336M04	33	A	1.3	0.10
NRW336M04	33	B3	1.3	0.12
NRS336M04	33	B2	1.3	0.08
NRA476M04	47	A	1.8	0.12
NRW476M04	47	B3	1.8	0.12

Part Number	Capacitance (μF)	Case Code	DC Leakage Current (μA)	Tangent of Loss Angle
4 V Rating				
NRS476M04	47	B2	1.8	0.08
NRC476M04	47	C	1.8	0.08
NRW686M04	68	B3	2.7	0.15
NRS686M04	68	B2	2.7	0.08
NRC686M04	68	C	2.7	0.08
NRW107M04	100	B3	4.0	0.20
NRS107M04	100	B2	4.0	0.12
NRC107M04	100	C	4.0	0.08
NRT107M04	100	D2	4.0	0.08
NRD107M04	100	D	4.0	0.08
NRS157M04	150	B2	6.0	0.18
NRC157M04	150	C	6.0	0.10
NRT157M04	150	D2	6.0	0.08
NRD157M04	150	D	6.0	0.08
NRC227M04	220	C	8.8	0.12
NRT227M04	220	D2	8.8	0.12
NRD227M04	220	D	8.8	0.08
NRC337M04	330	C	13.2	0.14
NRD337M04	330	D	13.2	0.14
NRD477M04	470	D	18.8	0.16
NRD687M04	680	D	27.2	0.24
2.5 V Rating				
NRU475M02	4.7	A2	0.5	0.08
NRU685M02	6.8	A2	0.5	0.08
NRU106M02	10	A2	0.5	0.08
NRU156M02	15	A2	0.5	0.12
NRA156M02	15	A	0.5	0.08
NRU226M02	22	A2	0.5	0.12
NRA226M02	22	A	0.5	0.08
NRA336M02	33	A	0.8	0.08
NRW336M02	33	B3	0.8	0.08
NRS336M02	33	B2	0.8	0.08
NRA476M02	47	A	1.1	0.12
NRW476M02	47	B3	1.1	0.12
NRS476M02	47	B2	1.1	0.08
NRA686M02	68	A	1.7	0.18
NRW686M02	68	B3	1.7	0.20
NRS686M02	68	B2	1.7	0.08
NRW107M02	100	B3	2.5	0.18
NRS107M02	100	B2	2.5	0.08
NRS157M02	150	B2	3.7	0.16
NRS227M02	220	B2	5.5	0.18
NRC227M02	220	C	5.5	0.12
NRT337M02	330	D2	8.2	0.14
NRC477M02	470	C	11.7	0.18
NRD477M02	470	D	11.7	0.14