

Description

The SMF-03140-200 is a packaged version of the SMF-03100-200. The chip is a 300 μm n-channel MESFET with 0.5 μm gate length, utilizing Samsung Microwave's gain optimized G10 process. The SMF-03100-200 active layer is formed by ion implantation. Ti/Pt/Au gate metallization and large "T" cross section minimize parasitic resistance while providing high reliability and ruggedness for RF overdrive. Ohmic metallization is Au/Ge/Ni.

Assembly techniques complement the ruggedness of the chip. Eutectic die attach, thermocompression wedge bonding with gold wire, and a 70 mil hermetically sealed metal/ceramic package make the SMF-03140-200 suitable for the most demanding applications.

The chip devices are selected from Samsung Microwave's Military Grade wafers, using 100% on-wafer DC probe data. The assembly process includes pre-cap visual inspection and 100% leak testing. Electrical tests include DC and RF performance to the Electrical Specifications listed.

Standard shipping containers are conductive Gel-Paks with conductive foam liners, sealed in metallized bags for additional ESD protection. When specified by Source Control Drawing, the SMF-03140-200 can be supplied with 100% screening and Quality Conformance Inspection, such as described in MIL-S-19500. Customers with special electrical test or screening requirements should contact the factory.

Features

- +19 dBm output power with 9.5 dB associated gain at 8 GHz
- 14 dB MAG with +14 dBm associated output power at 8 GHz
- Large cross section Ti/Pt/Au gates enhance durability and reliability
- Custom electrical test and screening available for source control drawings
- Chip devices are selected from standard Military Grade wafers
- Hermetic metal/ceramic package suitable for hi-rel applications

Package Outline

FET Package Type 40

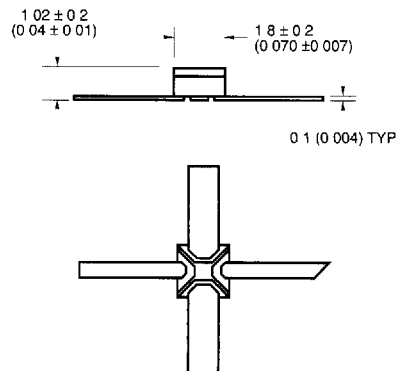
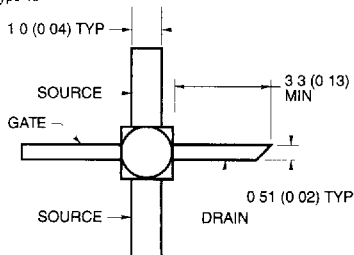

Dimensions in millimeters (inches)

RF Electrical Specifications at $T_A = 25^\circ\text{C}$ ($V_{DS} = 6.0\text{ V}$, $I_{DS} = 50\% I_{DSS}$)

Symbol	Parameter	Frequency	Units	Minimum	Typical	Maximum
MAG	Maximum Available Gain	8 GHz 12 GHz	dB	12.0	14.0 10.0	
P_{MAG}	Output Power at MAG Tuning	8 GHz 12 GHz	dBm		14.0 14.0	
P_{1dB}	Output Power at 1dB Gain Compression	8 GHz 12 GHz	dBm	18.0	19.0 19.0	
G_{1dB}	1dB Compressed Gain	8 GHz 12 GHz	dB		9.5 7.5	
NF_0	Optimum Noise Figure, $V_{DS} = 4.0\text{ V}$, $I_{DS} = 20\% I_{DSS}$	8 GHz	dB		1.5	

Note: Because Maximum Available Gain is not formally defined from the S-Parameters at some frequencies, values shown are Maximum Tuned Gain.

DC Electrical Specifications at $T_A = 25^\circ\text{C}$

Symbol	Parameters and Test Conditions	Units	Minimum	Typical	Maximum
I_{DSS}	Saturated Drain Current, $V_{DS} = 3.0\text{ V}$, $V_{GS} = 0\text{ V}$	mA	60	75	100
V_P	Pinch Off Voltage, $V_{DS} = 3.0\text{ V}$, $I_{DS} = 1.0\text{ mA}$	V	-3.1	-2.1	-1.0
g_m	Transconductance, $V_{DS} = 3.0\text{ V}$, $V_{GS} = 0$ to -0.5 V	mS		44	

Product Ratings

Symbol	Parameter	Maximum Operating Conditions	
		Recommended	Absolute
V_{DS}	Drain to Source Voltage	+7.0 V	+9.0 V
V_{GS}	Gate to Source Voltage	-3.5 V	-5.0 V
T_{CH}	Channel Temperature, Operating	+180°C	+250°C
T_{STG}	Storage Temperature	-65°C to +180°C	-65°C to +250°C

Note: Permanent damage may result from operation at conditions beyond absolute maximum ratings.

Typical S-Parameters ($V_{DS} = 6.0\text{ V}$, $I_{DS} = 50\% I_{DSS}$)

Frequency (GHz)	S_{11}		S_{21}			S_{12}			S_{22}	
	MAG	ANG	dB	MAG	ANG	dB	MAG	ANG	MAG	ANG
2.0	0.954	-50.2	9.41	2.956	133.5	-31.06	0.028	57.9	0.764	-28.2
3.0	0.891	-72.3	8.85	2.771	113.4	-28.64	0.037	44.7	0.733	-39.4
4.0	0.846	-95.4	8.49	2.657	93.5	-26.74	0.046	30.4	0.701	-50.7
5.0	0.811	-120.4	8.20	2.570	72.3	-26.20	0.049	18.0	0.671	-63.0
6.0	0.786	-146.0	7.70	2.428	51.0	-25.85	0.051	7.7	0.642	-77.6
7.0	0.756	-169.8	6.78	2.182	30.5	-26.20	0.049	1.6	0.624	-94.5
8.0	0.736	172.1	5.66	1.919	13.1	-26.74	0.046	-2.2	0.612	-111.8
9.0	0.744	159.3	4.92	1.763	-1.7	-26.94	0.045	-1.4	0.609	-127.4
10.0	0.765	146.1	4.40	1.659	-16.7	-26.56	0.047	3.1	0.625	-140.9
11.0	0.774	131.1	3.78	1.545	-33.1	-25.35	0.054	5.4	0.661	-154.9
12.0	0.754	117.4	2.60	1.348	-48.9	-23.35	0.068	-2.9	0.676	-171.7
13.0	0.719	108.9	1.89	1.242	-62.5	-23.22	0.069	-9.1	0.675	174.9
14.0	0.682	101.7	1.23	1.152	-72.0	-23.50	0.075	-13.9	0.667	165.0

Typical S-Parameters ($V_{DS} = 4.0\text{ V}$, $I_{DS} = 50\% I_{DSS}$)

Frequency (GHz)	S_{11}		S_{21}			S_{12}			S_{22}	
	MAG	ANG	dB	MAG	ANG	dB	MAG	ANG	MAG	ANG
2.0	0.954	-49.5	9.80	3.091	134.2	-29.90	0.032	58.3	0.708	-29.0
3.0	0.892	-71.3	9.25	2.901	114.4	-27.33	0.043	44.6	0.678	-40.6
4.0	0.846	-94.1	8.87	2.776	94.7	-25.51	0.053	30.1	0.643	-52.4
5.0	0.812	-118.9	8.61	2.696	73.7	-24.73	0.058	16.9	0.607	-65.2
6.0	0.787	-144.3	8.11	2.544	52.6	-24.29	0.061	5.3	0.571	-80.5
7.0	0.752	-168.2	7.21	2.294	32.4	-24.43	0.060	-3.0	0.548	-97.5
8.0	0.732	173.6	6.10	2.019	15.3	-24.88	0.057	-9.6	0.536	-114.9
9.0	0.739	160.8	5.36	1.853	0.8	-25.35	0.054	-12.2	0.537	-130.5
10.0	0.756	147.6	4.80	1.737	-13.9	-25.35	0.054	-10.6	0.553	-143.9
11.0	0.766	132.6	4.22	1.625	-29.9	-24.73	0.058	-9.7	0.585	-157.9
12.0	0.747	119.0	3.11	1.430	-45.6	-23.22	0.069	-15.3	0.606	-174.9
13.0	0.716	110.6	2.38	1.315	-59.6	-23.35	0.068	-22.2	0.603	172.7
14.0	0.678	103.8	1.80	1.230	-68.5	-22.97	0.071	-25.9	0.603	163.2

Noise Figure and Gain Performance

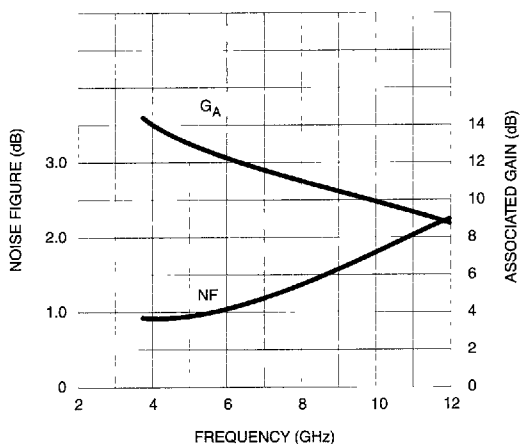

Typical Noise Figure and Associated Gain vs Frequency $V_{DS} = 4.0\text{ V}$, $I_{DS} = 20\% I_{DSS}$

Typical S-Parameters ($V_{DS} = 4.0\text{ V}$, $I_{DS} = 20\% I_{DSS}$)

Frequency (GHz)	S_{11}		S_{21}			S_{12}			S_{22}	
	MAG	ANG	dB	MAG	ANG	dB	MAG	ANG	MAG	ANG
2.0	0.960	-46.7	8.35	2.614	135.7	-28.40	0.038	57.8	0.703	-29.6
3.0	0.908	-67.3	7.87	2.474	116.3	-25.51	0.053	43.8	0.674	-41.6
4.0	0.865	-89.1	7.59	2.396	96.9	-23.61	0.066	29.0	0.639	-53.9
5.0	0.832	-112.9	7.45	2.356	76.1	-22.62	0.074	14.5	0.600	-67.4
6.0	0.804	-137.9	7.07	2.257	55.0	-21.94	0.080	0.4	0.560	-83.6
7.0	0.769	-162.2	6.24	2.051	34.4	-22.05	0.079	-11.2	0.532	-101.2
8.0	0.741	179.0	5.17	1.812	16.9	-22.62	0.074	-21.6	0.519	-118.6
9.0	0.746	166.0	4.42	1.663	2.2	-23.22	0.069	-28.4	0.520	-134.2
10.0	0.762	152.7	3.89	1.565	-12.4	-23.88	0.064	-30.4	0.537	-147.5
11.0	0.774	137.6	3.32	1.466	-28.5	-24.15	0.062	-31.4	0.566	-161.7
12.0	0.753	123.6	2.32	1.306	-44.2	-22.97	0.071	-36.3	0.583	-178.4
13.0	0.723	115.1	1.56	1.197	-58.2	-23.88	0.064	-43.6	0.582	169.1
14.0	0.687	108.4	0.90	1.109	-67.3	-23.88	0.064	-44.6	0.583	160.1