



RJ45 CAT 5E ETHERNET

Series ITS (5015 type) Reverse-Bayonet



ITS301 Connector with Accessory Threads and Plug (Plug) or Jack (Receptacle) to Crimp Removable Contacts



How to Order							
Sample Part Number	ITS301	030	G	18	5E	1	F7
Basic Number	ITS301						
Connector Style¹	030 = Rear Panel Mount Square Flange Receptacle 01 = InLine Receptacle 070 = Rear Panel Mount Jam Nut Receptacle 06 = Straight Plug Connector						
Insert-to-Shell Grounding	G = Insert grounded to shell (for use with shielded cable) (Use only with G3, F11 or F7 finish) Omit = for none						
Shell Size	18						
RJ45 Category	5E = Cat 5E For Cat 6A applications consult factory						
RJ45 Orientation	1, 2, 3 or 4						
Material/Finish	Omit for Aluminum/Cadmium, Olive Drab (G3) F6 = Aluminum/Black Polymer Electrocoat F7 = Aluminum/Conductive Black Zinc Nickel F11 = Aluminum/Electroless Nickel						

RJ45 Orientation Options (Plug Shown)

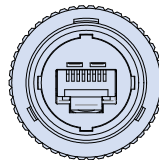

Code 1

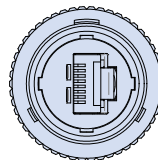

Code 2

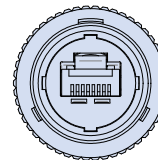

Code 3

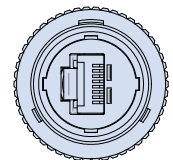

Code 4

06 - PLUG WITH ACCESSORY THREADS

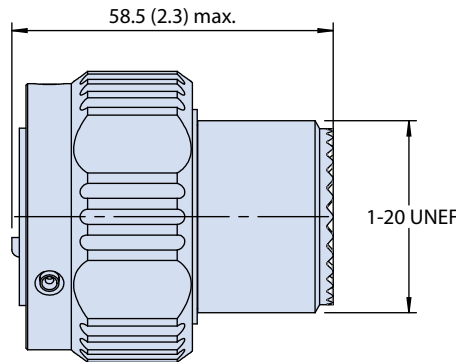
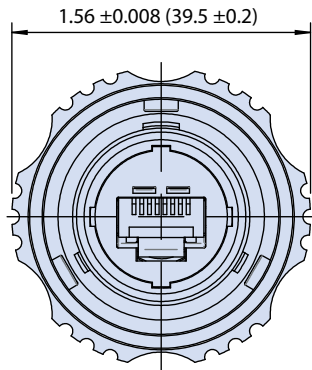

PLUG AND RECEPTACLE REAR TERMINATION VIEW

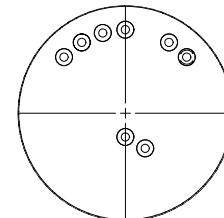

NOTES

1. See Section A for panel cutout dimensions
2. Crimp removable size 22 contacts (M39029/58-360) supplied loose



RJ45 CAT 5E ETHERNET

Series ITS (5015 type) Reverse-Bayonet



ITS301 Connector with Accessory Threads and Plug (Plug) or Jack (Receptacle) to Crimp Removable Contacts

01 - INLINE RECEPTACLE WITH ACCESSORY THREADS

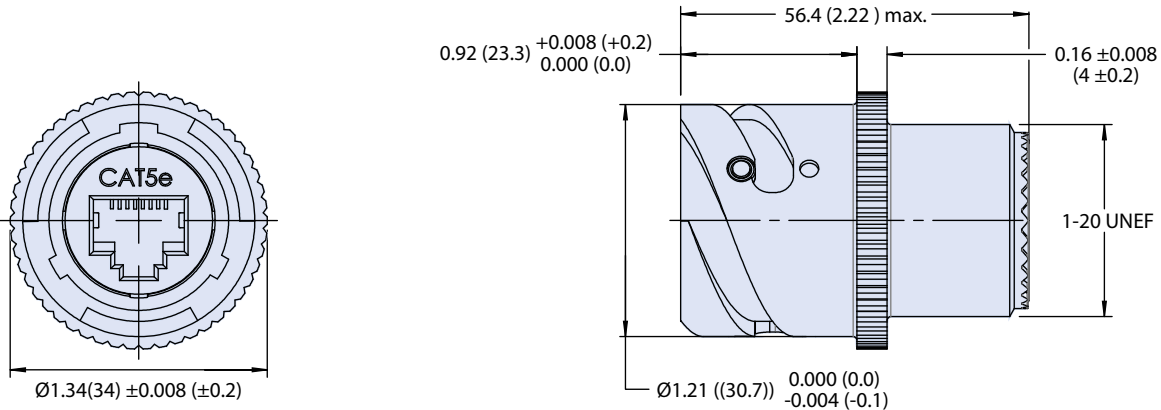

070 - REAR PANEL MOUNT JAM NUT RECEPTACLE WITH ACCESSORY THREADS

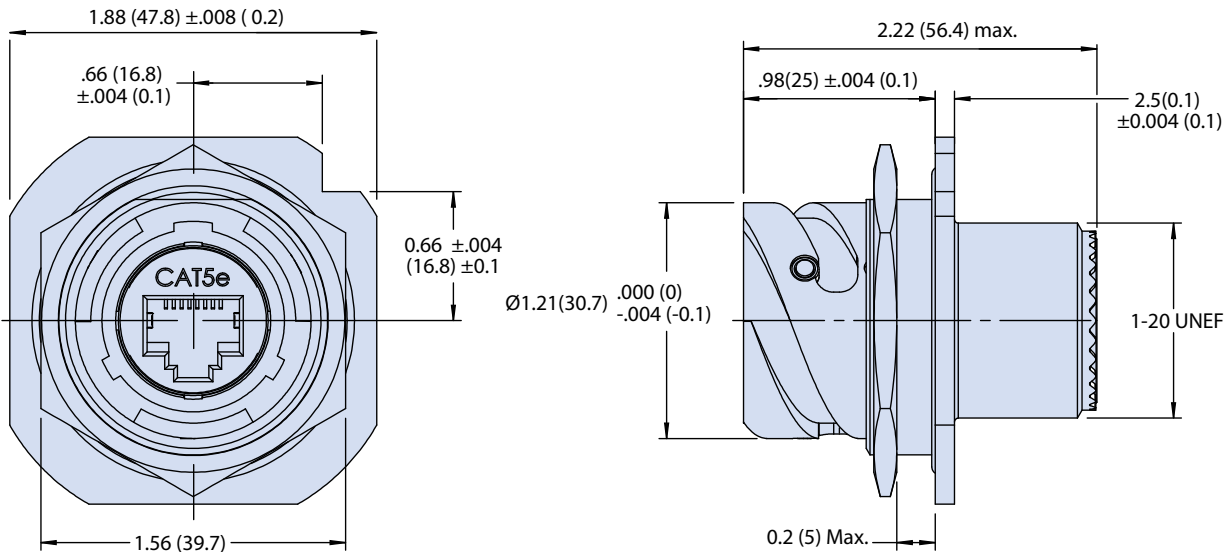

030 - REAR PANEL MOUNT SQUARE FLANGE RECEPTACLE WITH ACCESSORY THREADS

