

V.22bis High Performance AFE

GENERAL DESCRIPTION

The XR-2402A High Performance AFE (Analog Front End) is designed to directly interface to the XR-2401 DSP Modem Signal Processor to provide the complete V.22bis 2400 BPS modem function. The XR-2401 is described in detail on the XR-2400 datasheet.

The XR-2402A is a redesigned, enhanced version of the XR-2402. While maintaining pin-to-pin compatibility with the XR-2402, the XR-2402A offers improved low signal level performance. Circuitry has also been added for speaker volume (during CPM) control under 'AT' command set control (ATL 0,1,2,3).

The XR-2402A provides analog interface functions to support the XR-2401 DSP such as, 8 bit D/A and A/D converters allow analog signals to get into and out of the digital XR-2401 DSP chip. Also included are band splitting filters (SCF type), a programmable gain amplifier (PGA), synchronous to asynchronous and asynchronous to synchronous conversion, guard tone generation (CCITT Operation), and timing recovery circuitry.

The XR-2402A is constructed with Si-Gate CMOS technology for low power operation. The XR-2402A is available in a 48 pin DIP or 52 pin PLCC package, and operates from ± 5 Volt power supplies.

FEATURES

- (When used with the XR-2401 DSP)
- Pin-to-Pin Compatible with XR-2402
- Improved Low Level Performance (Compared to XR-2402) 2400 BPS (QAM), 1200 BPS (PSK), 300 BPS (FSK) Operation
- V.22bis, V.22, 212A, 103 Compatible
- Bus Structure Control
- DTMF Control
- Low Power CMOS (110 mw typ)
- Power - Down Mode
- Asynchronous / Synchronous Operation
- Speaker Volume Control Via Control Register
- MNP 5 Operation with XR-2403/B
- V.42 Upgradeable with XR-2442
- V.42bis Upgradeable with XR-2443

PIN ASSIGNMENT

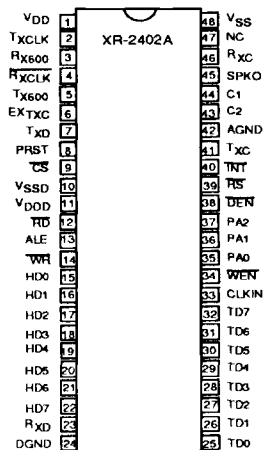

(Please see last page for PLCC and QFP packages)

APPLICATIONS

- Stand-alone Modems
- Internal Modems
- Laptop Applications
- Low Power Applications

ABSOLUTE MAXIMUM RATING

Power Supply	
VDD	-0.3 to +7V
VSS	+0.3 to -7V
Input Voltage	VSS -0.3V to VDD +0.3V
DC Input Current (Any Input)	± 10 mA
Power Dissipation(Package Limitation)	1 Watt
Storage Temperature Range	-65°C to +125°C

ORDERING INFORMATION

Part Number	Package	Operating Temperature
XR-2402ACP	40 Pin Plastic Dip	0°C to 70°C
XR-2402ACJ	52 Pin Plastic PLCC	0°C to 70°C
XR-2402A	52 Pin QFP	0°C to 70°C

XR-2402A

ELECTRICAL CHARACTERISTICS

Test Conditions: $T_A = 25^\circ\text{C}$, $V_{DD} = 5V \pm 10\%$, $V_{SS} = -5V \pm 5\%$, $f_{CLKIN} = 4.9152 \text{ MHz} \pm 0.01\%$,
unless otherwise specified.

SYMBOL	PARAMETER	MIN	TYP	MAX	UNIT	CONDITIONS
V_{DD}	Positive Supply Voltage	4.75	5.0	5.25	V	
V_{SS}	Negative Supply Voltage	-5.25	-5.0	-4.75	V	
I_{DD}	Positive Supply Current		11	20	mA	
I_{DDs}	Positive Supply Current Standby mode		3	5	mA	
I_{SS}	Negative Supply Current		11	20	mA	
I_{SSs}	Negative Supply Current		3	5	mA	
V_{IH}	High Level Input Voltage	2.0			V	
V_{IL}	Low Level Input Voltage			0.8	V	
I_{OH}	High Level Output Current			300	μA	$V_{OH} = 2.4V$
I_{OL}	Low Level Output Current			2	mA	
V_{OH}	High Level Output Voltage	2.4			V	$I_{OL} = 700 \mu\text{A}$
I_I	Input Current			50	μA	$V_I = 0 \text{ to } V_{DD}$
R_{XC}	Receive Carrier Range	-45		-6	dBm	Using 6/16 dB gain feature measured at tip and ring of Figure 2. RCVG feature (Pin 46 is 3 dB higher than tip and ring)
Speaker Controlled by Bits 6 and 7 of Location 60H - CNTRL 0						
AVSPKR	Gain - RXC TO SPKO					$AVSPKR = 20 \text{ Log } \frac{V_{SPKO}}{V_{RXC}}$
						BIT 7 BIT 6
AVSPKR 1		4	6	8	dB	0 0
AVSPKR 2		-5	-3	-1	dB	0 1
AVSPKR 2		-5	-3	-1	dB	1 0
AVSPKR 3		-14	-12	-10	dB	1 1

TRANSMITTER SPECIFICATIONS

All values are measured at TXC (Pin 41) of the XR-2402A with Bit 0-2 = 1 of CNTRL 0.

SYMBOL	PARAMETER	MIN	TYP	MAX	UNIT	CONDITIONS
TRANSMITTER POWER						
T _{XC} QAM/PSK	QAM/PSK Transmitter Power	-6			dBm	
T _{XC} 550	CCITT Guard Tone Power	-1.7		-4	dBm	
T _{XC} 1800		-5.2		-3.4	dBm	
T _{XC} QAM/PSK 550	QAM/PSK Transmitter Power With Guard Tone	1.9			dBm	
T _{XC} QAM/PSK 1800		-8			dBm	
T _{XC} FSK	FSK Transmitter Power	-.16		2.5	dBm	
T _{XC} AT	Answer Tone Power	1.6		2.9	dBm	
T _{XC} DTMF C	DTMF Tone Power Column	-4.9		-3.1	dBm	
T _{XC} DTMF R	DTMF Tone Power Row	-6.2		-4.4	dBm	
ΔT _{XC} DTMF T	DTMF Tone Power Twist	-2		2	dB	

3

SYSTEM PERFORMANCES (Performance Test Set-up Shown in Figure 1)

VRXC= -40 dBm, Originate Mode, C2, 3002, or B/B Line Conditions, TXC = -10 dBm.

SYMBOL	PARAMETER	MIN	TYP	MAX	UNIT	CONDITIONS
S/N	Signal-to-Noise Ratio		16 9 12		dB dB dB	2400 BPS 1200 BPS 300 BPS
FOFF	Frequency Offset		±10		Hz	2400/1200 BPS
R _{XC} Min	Minimum Receive Carrier Carrier Level For Error Free Operation		-45		dBm	2400 BPS

XR-2402A

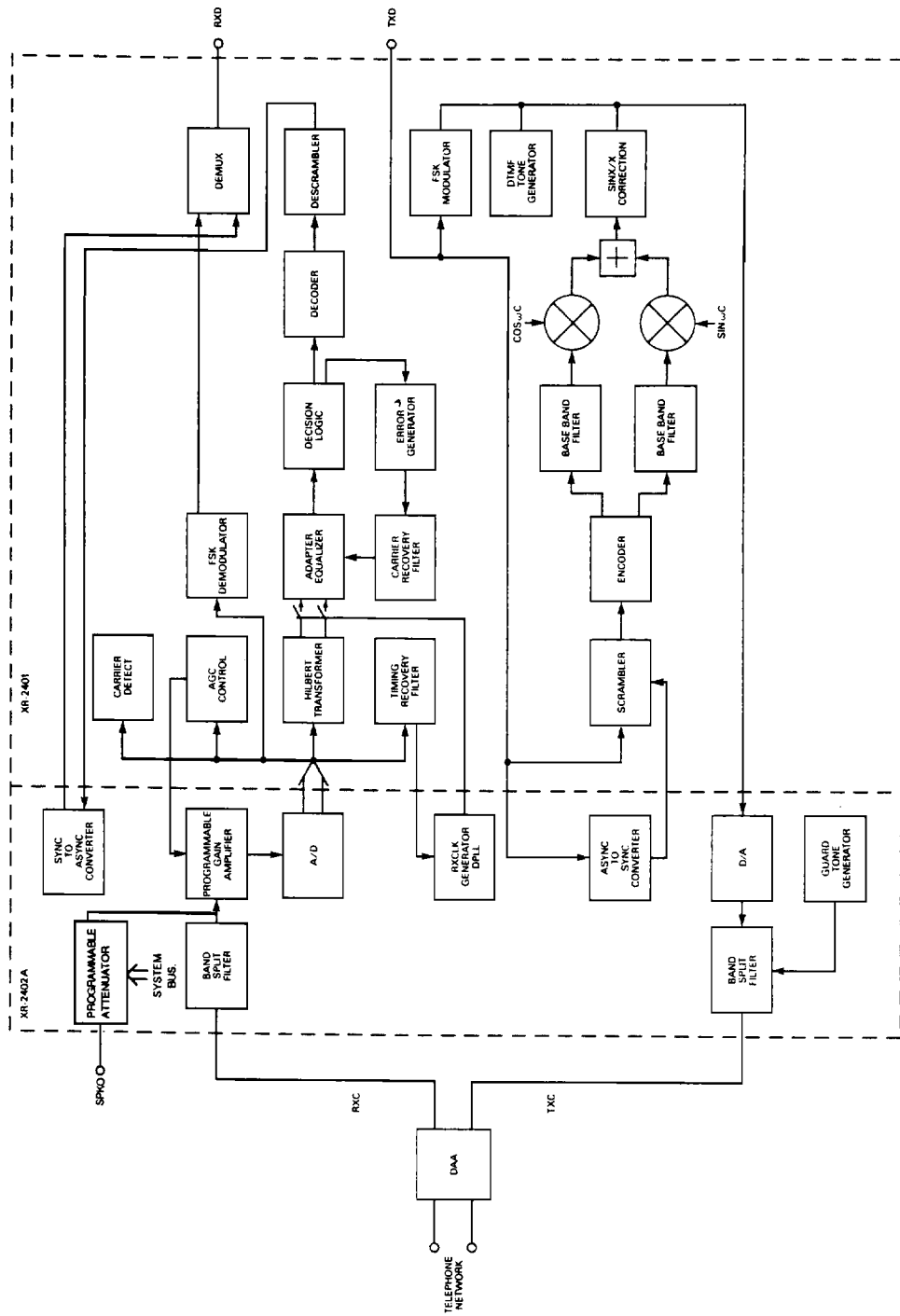

XR-2400A Functional Block Diagram

SYSTEM DESCRIPTION

The XR-2402A offers additional features and performance enhancements over the original XR-2402, such as those listed below:

	XR-2402A	XR-2402
Speaker Volume Control	Internal	External Latch and 2 transistors
Minimum Receive Level for Error-Free Operation	-45dBm	-43dBm
Typical Power Consumption	110 mw	160 mw

MICROCONTROLLER OPTIONS

The XR-2402A, when used with the XR-2401 modem DSP (See XR-2400 Datasheet for details) forms the complete V.22bis modem data pump function.

The XR-2402A/2401 pair, requires a modem controller for supporting intelligent functions such as Hayes 'AT' command control, error correction and data compression.

The XR-2402A has been designed with a very flexible interface to accommodate various common microcontrollers. Exar provides a number of different options and programs to minimize the design cycle. In each case, production worthy, commented source code is provided for use as is or for user customization to individualize each particular design.

Refer to Figure 3 for general connection.

XR-2402A

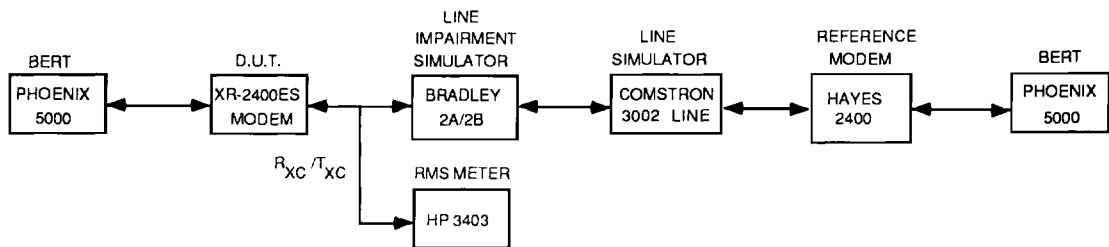

Figure 1. Performance Test Set-up

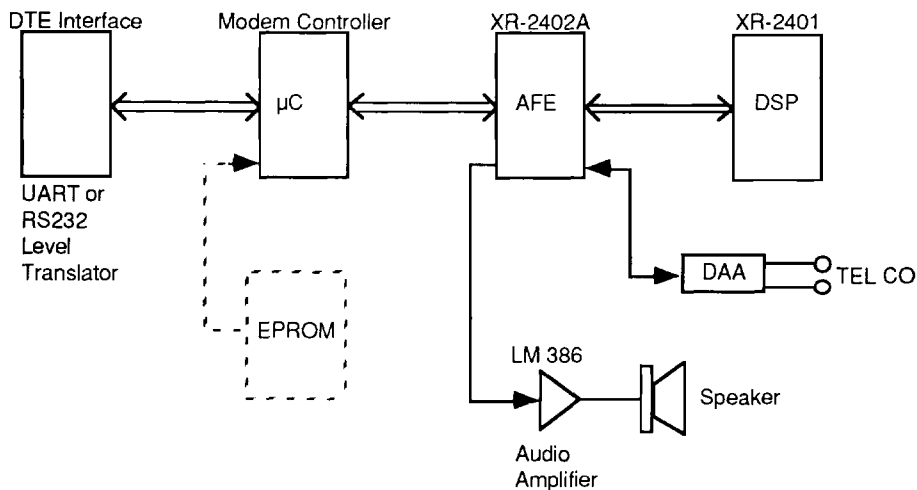

Figure 2. Typical System Connection

APPLICATIONS INFORMATION

Detailed descriptions and operation of the XR-2402A may be found on the XR-2400 datasheet which describes the pin-to-pin and functionally equivalent XR-2402. The information provided here is additional.

Speaker Volume Control

The XR-2402A provides a complete digitally controlled, three level, speaker driver. The control for the driver is located in:

Location 60H - CNTRL 0

Bit	Description
0	TXL1
1	TXL2
2	TXL3
3	SPKR On/Off (O = Off)
4	TST1 (Exar Special Test Mode)
5	TST2 (Exar Special Test Mode)
6	SPKR 1 Speaker Control LSB
7	SPKR 2 Speaker Control MSB

The output levels relative to command / logic levels are:

Gain From RXC (P46) to SPK0	Bit 7	Bit 6
6 dB ±3 db	0	0
-3 dB ±3 db	0	1
-3 dB ±3 db	1	0
-12 dB ±3 db	1	1

DESIGN CONSIDERATIONS

A complete V.22bis modem system is shown in XR-2400 ES modem schematic available from EXAR applications department.

Several design considerations must be followed in order to ensure optimum system performance, as follows:

1. System Grounding - The XR-2402A provides both analog and digital grounds. These grounds should be separate up to the actual power supply ground, and single point connected there.

2. Power Supplies - Power supply bypassing should be provided at several points throughout the PCB. At the power input both a high frequency capacitor (0.1µF) and larger type (4.7 µF) for current transients. Particular should be taken to provide bypassing for the XR-2402A, located near the chip.

3. Receive Carrier Input RXC - Care must be taken to route the RXC trace such that it is not near any crystals or logic IC's, in order to keep a clean layout the XR-2402A should be placed on the printed circuit layout near the telephone interface (DAA).

PERFORMANCE

One of the main parameters used as the yardstick to compare modems is the probability of producing errors while subjected to noise, commonly known as bit error rate verses signal-to-noise ratio (BER vs. S/N). The data supplied here was measured by an independent modem test house, Telequality Ass. in Colorado.

Bit error Rate measurement results are shown in Fig 3. This test is purely a measure of the data pump, XR-2402A / XR-2401.

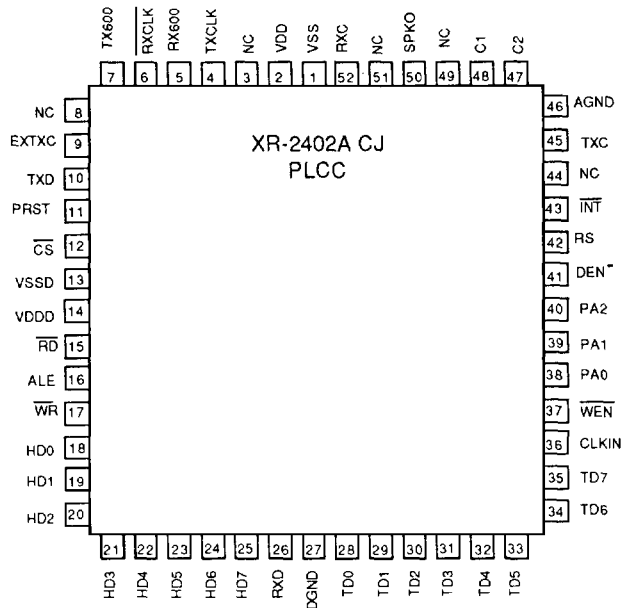
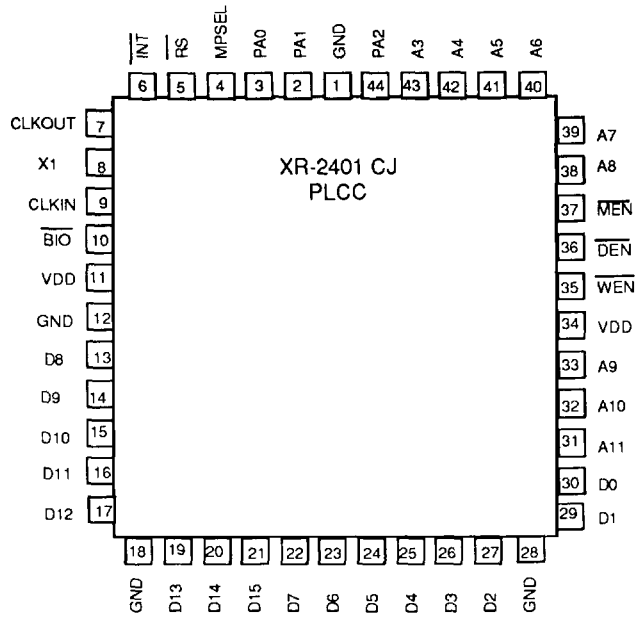

3

XR-2402A

