

Features:

- 125Mbps to 155Mbps bi-directional, single fiber transmission
- Industry standard MSA 2x5 electrical footprint
- Simplex LC optical connector interface
- Rugged through-hole mounting posts and rear ground case posts
- Full-metal case to optimize EMI performance
- MIL-STD-883 mechanical shock and vibration compliant
- -40°C to +85°C operating temperature
- EN-60825/IEC-825/CDRH Class 1 compliant 1310/1550 Fabry-Perot Lasers
- +3.3V Power Supply
- Parylene C conformal coating option
- Options for AC-coupled or DC-coupled data
- Options for LVPECL or LVTTTL signal detect



The SFB-M-xx-xx is ideal for harsh environment connectivity because of its low cost, availability, and wide operating parameters



COMMERCIAL AEROSPACE

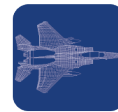

MILITARY AEROSPACE



MILITARY TACTICAL



SUBSEA NETWORKING

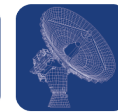

RADAR & SENSING



OIL & EXPLORATION

Absolute Maximum Ratings

Parameter	Symbol	Min.	Max.	Unit	Note
Power Supply Voltage	V _{CC}	0	3.6	V	
Operating Temperature	T _{OP}	-40	85	°C	
Storage Temperature	T _{STG}	-55	100	°C	
Soldering Temperature	-	-	260	°C	(1)
Relative Humidity	RH	-	100	%	Non-condensing, (2)
MM Link Distance (62/125µm)	-	-	550	m	(3)
SM Link Distance (9/125µm)	-	-	20	km	(4)
Conformal Coating	-	0.8	1.2	mil	(5)

Notes:

1. 10 seconds, leads only. The parts should not undergo wave soldering.
2. Based on conformal coating.
3. MMF links cannot include any air gaps, such as those found in expanded beam connections.
4. Assuming a fiber loss of 0.5dB/km
5. Parylene C coating

General Specifications

Parameter	Symbol	Min.	Typ.	Max.	Unit	Notes
Power Supply Voltage	V _{CC}	3.1	3.3	3.5	V	
Data Rate	-	-	155	-	Mbps	
Optical Link Budget on Single-Mode	dB	16	20	22	dB	
Optical Link Budget on Multimode	dB	17	19	22	dB	



Electrical Specifications ($T_{OP} = -40^{\circ}C$ to $+85^{\circ}C$, $V_{CC} = 3.14V$ to $3.47V$)

Parameter	Symbol	Min	Typ	Max	Unit	Notes
Transmitter Specifications						
Supply Current	I_{CC}	-	-	125	mA	(1)
Tx Differential Input Voltage	V_{DI}	200	-	2400	mV _{P-P}	AC-coupled LVPECL
Tx Input Differential Impedance	R_{IN}	90	100	110	Ω	
Transmitter Disable Voltage	V_{DIS}	2	-	V_{CC}	V	LVTTTL
Transmitter Enable Voltage	V_{EN}	0	-	0.8	V	(2)
Receiver Specifications						
Supply Current	I_{CC}	-	-	125	mA	(1)
Output Differential Impedance	Z_{OUT}	90	100	110	Ω	
Data Output - Voltage Low	$V_{OL-V_{CC}}$	-2.0	-	-1.58	V	DC-coupled LVPECL
Data Output - Voltage High	$V_{OH-V_{CC}}$	-1.1	-	-0.74	V	DC-coupled LVPECL
Data Output - Differential Swing	V_{DIFF}	400	1600	2400	mV	AC-coupled LVPECL
Data Output Rise/Fall Time	t_r/t_f	-	-	2.2	ns	(3)
Signal Detect Output - Voltage Low	V_{SDL}	0.0	-	0.5	V	LVTTTL
Signal Detect Output - Voltage High	V_{SDH}	2.0	-	V_{CC}	V	LVTTTL
Signal Detect Output - Voltage Low	V_{SDL}	1.50	-	1.90	V	LVPECL, (4)(5)
Signal Detect Output - Voltage High	V_{SDH}	2.40	-	2.80	V	LVPECL, (4)(5)
Notes:						
1. Maximum Current is defined at maximum operating temperature at the maximum allowable V_{CC}						
2. Default is transmitter enabled using an internal 10k Ω pull-down resistor						
3. Measured at $P_{in} = -24dBm$, 20%/80% values						
4. LVPECL signal detect voltages valid for pull-down resistors ranging in value from 130 Ω to 220 Ω , measured with a DVM						
5. Values represent nominal supply voltage of 3.3V						

Pin Configuration

PIN #	Symbol	Description	Notes
1	V_{EER}	Receiver signal ground	0V
2	V_{CCR}	Receiver power supply	3.3V nominal
3	SD	Signal detect output	LVTTTL or LVPECL
4	RD-	Receiver data out -	AC- or DC-coupled LVPECL
5	RD+	Receiver data out +	AC- or DC-coupled LVPECL
6	V_{CCT}	Transmitter signal power	3.3V nominal
7	V_{EET}	Transmitter signal ground	0V
8	T_{DIS}	Transmitter disable	LVTTTL
9	TD+	Transmitter data in +	AC-coupled LVPECL
10	TD-	Transmitter data in -	AC-coupled LVPECL

Note:

- 1) Mounting studs and solder posts are chassis ground
- 2) Mounting studs are swaged gold-plated pins for solderability
- 3) Solder posts are an extension of the sheet metal case and are optional. See plating note in "Ordering Information."

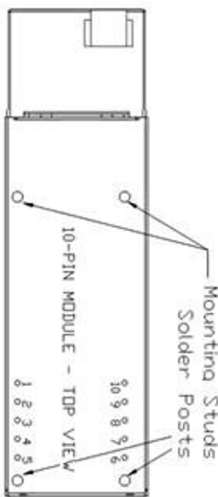



Optical Characteristics (T_{OP} = -40°C to +85°C, V_{CC} = 3.14V to 3.47V)

Parameter	Symbol	Min.	Typ.	Max.	Unit	Notes
Transmitter Specifications						
Transmit Power: SMF	P _{o-SMF}	-14	-	-8	dBm	(1)(2)
Transmit Power: MMF	P _{o-MMF}	-9	-	-3	dBm	(1)(3)
Coupled Power Ratio	CPR	-	3	-	dB	
Output Center Wavelength	λ _T	1260	1310	1360	nm	1310 Tx/1550 Rx option
Output Center Wavelength	λ _T	1480	1550	1580	nm	1550 Tx/1310 Rx option
Output Spectral Width	σ	-	-	3	nm	RMS
Extinction Ratio	ER	8.2	12	-	dB	
Optical Rise/Fall Time	t _r /t _f	-	2	2	ns	10% to 90% values
Optical Isolation		30	-	-	dB	BOSA transmitter isolation
Relative Intensity Noise	RIN	-	-	-116	dB/Hz	
Total Contributed Jitter	TJ	-	-	1	ns	(5)
Receiver Specifications						
Receiver Sensitivity	RX _{SENS}	-	-	-33/-31	dBm	9/125μm SMF, 62.5/125μm MMF
Receiver Saturation	P _{in}	-3	-	-	dBm	(4)
Signal-Detect Assert	P _a	-	-	-33	dBm	
Signal-Detect De-Assert	P _d	-41	-	-	dBm	
Signal-Detect Hysteresis	P _h	1	-	4	dB	
Optical Return Loss (ORL)	ORL	12	-	-	dB	
Wavelength of Operation	λ _R	1480	1550	1580	nm	1310 Tx/1550 Rx option
Wavelength of Operation	λ _R	1260	1310	1360	nm	1550 Tx/1310 Rx option
Notes:						
1. Class 1 laser eye safe, IEC-60825-1 compliant						
2. Measured at the end of a 2m SMF jumper						
3. Measured at the end of a 2m 62.5μm MMF jumper						
4. Measured using 9μm SMF and optical attenuator						
5. Measured with SMF at 2 ²³ -1 PRBS, BER= 10 ⁻¹⁰						





Application Schematics

Recommended Host Board Application Schematic

(AC-Coupled)

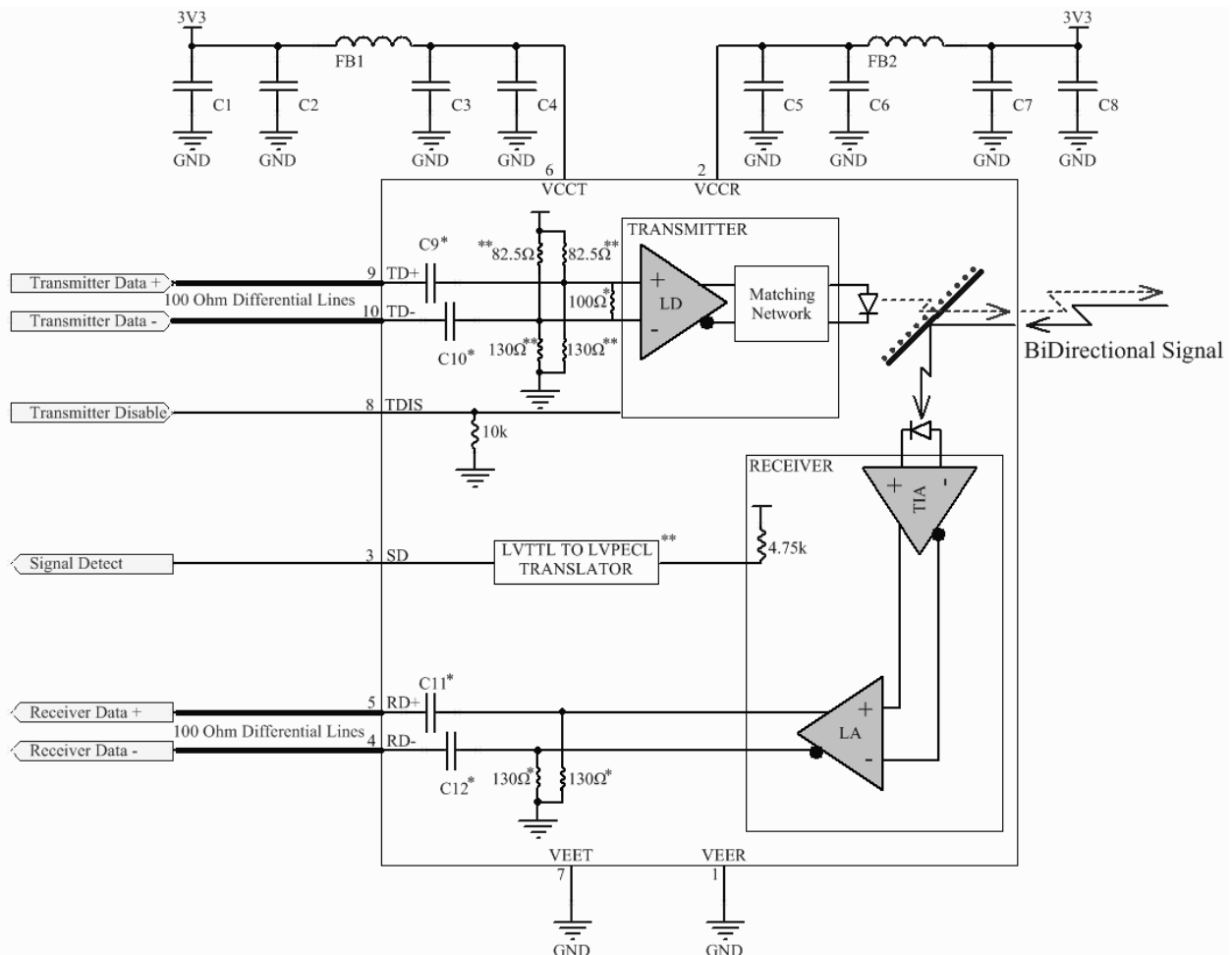

Notes:

- Configuration above is shown for AC-Coupled LVPECL transmitter inputs
- Configuration above is shown for AC-Coupled LVPECL receiver outputs
- Configuration above is shown for LVTTTL SD
- Recommend host routes separate supply voltages and filtering for SFF-module transmitter and receiver as shown in the schematic above
 - FB1/FB2 ferrite bead for power supply noise suppression; Murata BLM18KG601SN1, 0603, 600Ω @ 100MHz, 1300mA
 - C1/C4/C5/C8 bulk capacitance; Murata GRM21BR61C106KE15L, 0805, 10μF, 16V
 - C2/C3/C6/C7 de-coupling capacitors; Murata GRM155R71C104KA88D, 0402, 0.1μF, 16V
 - C9/C10/C11/C12 X7R 0.1μF, 16V coupling capacitors
- Mounting studs/solder posts must be connected to chassis ground in a bezel mounted application
- Recommend mounting studs/solder posts be connected to chassis ground if available in embedded applications. Otherwise, they should be tied to a local signal ground
- * Denotes optional components populated in the configuration shown
- ** Denotes optional components not populated in the configuration shown
- For alternate configurations please contact COTSWORKS application engineering for recommended application schematic recommendations



Mechanical Dimensions

Dimensions are defined by the Small Form Factor (SFF) Transceiver Multi-Source Agreement (MSA), July 5, 2000. <https://cotsworks.com/support-documents/>

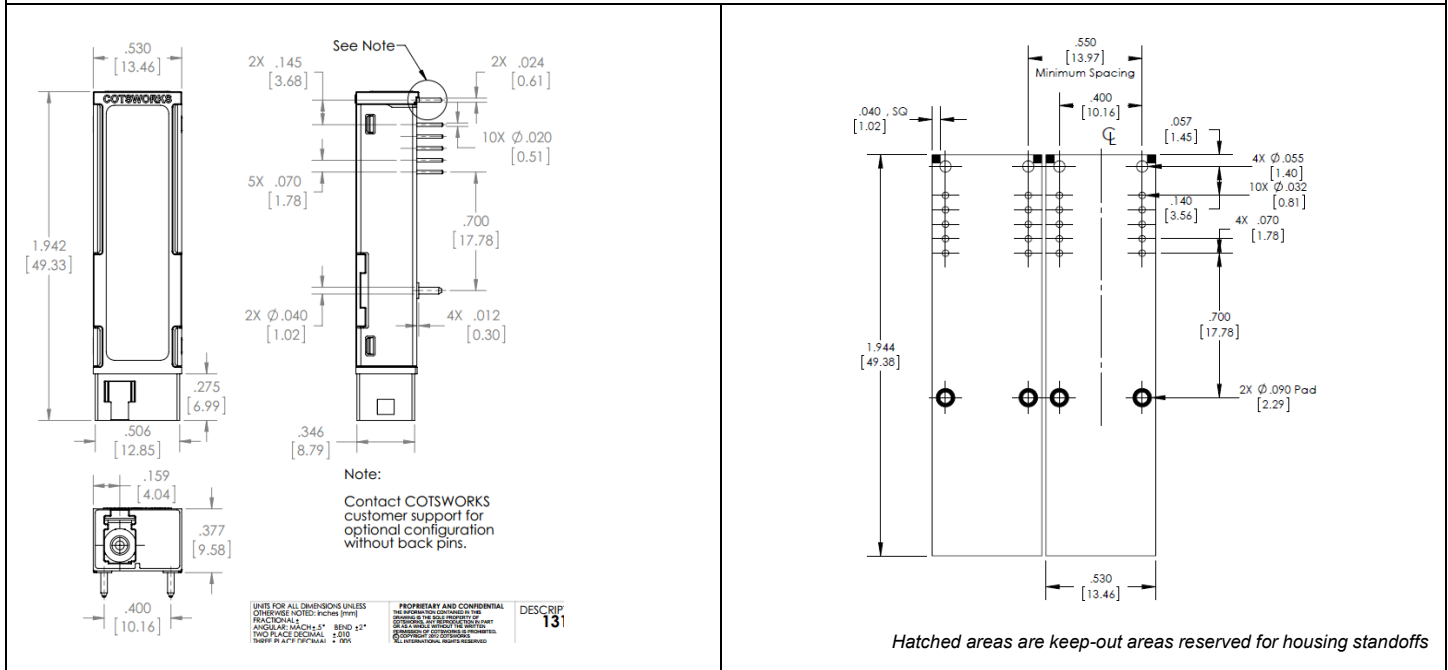

Ruggedization Notes

- A conformal coating of at least 0.8mil and not exceeding 1.2mil is applied to the PWB on both sides. The coating material is Parylene® Type C. It is applied to meet Type C Military specification 46085C.
- Contact COTSWORKS for MSDS, case composition, and burn analysis information.

Warnings:

Handling Precautions: This device is susceptible to damage from electrostatic discharge (ESD). A static free environment is highly recommended.

Laser Safety: Radiation emitted by laser devices can be dangerous to human eyes. Avoid eye exposure to direct or indirect radiation.

Ordering Information

SFB-M-	XX	-XX-	X	-X-	X
SFF Form Factor	Wavelength	Coupling & SD Logic	Coating	Operating Temp Range	Post Option
Single Fiber	35: 1310Tx/1550Rx	AT: AC coupled, TTL SD	(): Non-coated	A: -40 to 85°C	(): No Posts
125Mbps	53: 1550Tx/1310Rx	DP: DC coupled, PECL SD	R: Parylene		P: Solder Posts*

Example part number: SFB-M-35-DP-R-A-P

[Single fiber (bi-directional) SFF, 155Mbps, 1310nm Tx, 1550nm RX, DC-coupled, PECL signal detect logic, Parylene-coated, industrial operating temp. range, solder posts]

*Solder post option includes 90/10 tin/lead plating to enable soldering to host PCB while mitigating tin-whiskering concerns. No post option includes no plating.

COTSWORKS and the COTSWORKS logo are registered trademarks of COTSWORKS, INC. COTSWORKS reserves the right to change, alter, or revise this document without notice unless otherwise agreed to.