

### Description

Modular distribution rail, each module accommodating 2 magnetic or hydraulic-magnetic circuit breakers type 8340-F... and associated load terminals. Circuit breaker status indication (group signalling) is via 2 busbars. Power supply is via right- or left-side terminal block. Live parts in the plug-in and supply feed terminal areas are protected against brush contact. Circuit breakers may be replaced with power on.

### Typical applications

Telecommunications and cellular communication systems

### Ordering information

#### Type No.

**X8340** Distribution rail for circuit breaker type 8340

#### Version

**S** rail

#### Identification number

**02** modular, for 2 circuit breakers

#### Power supply

**L** left-side

**R** right-side

#### Modules with power supply

**2** 2 modules, 2-way each

**3** 3 modules, 2-way each

.. ..

#### Signalisation

**0** without signalling

**1** group signalling

**3** single signalling

#### Accessories

**00** without

**01** cover per module

**09** mounting screw M4 (bulk shipped)  
+ ground stud M6

**10** cover per module + mounting screw M4  
(bulk shipped) + ground stud M6

**X8340 - S 02 L 2 - 1 01** ordering example

### Approvals

Authority	Voltage ratings	Current ratings
UL 1801	AC 250 V; DC 80 V	100 A



**X8340-S02**

### Technical data

For circuit breaker type	8340-F.10-P1..-H...	
Voltage rating	AC 230 V; DC 80 V	
Load	25 A per position (30 A upon request) 132 A for complete unit	
Signalisation (N/C)	6 A, AC 230 V 1 A, DC 80 V per position	
Insulation co-ordination (IEC 60664 and 60664A)	Rated impulse withstand voltage 2.5 kV	Pollution degree 2
Flame retardance (IEC 60695, part 2-2)	self-extinguishing	
<b>Supply terminal design</b> (terminal socket)	recessed screw/pressure plate 6...50 mm <sup>2</sup> , stranded feed-in 6...35 mm <sup>2</sup> with connector sleeve additional blade terminals 6.3x0.8	
load (module)	blade terminals 6.3x0.8 load output terminal protected against reverse polarity	
signalisation (module)	blade terminals 4.8x0.8	
<b>Mass</b>		
terminal block	144 g	
power distribution module	96 g	
cover	12 g	

## Dimensions

**Distribution rail, shown with power supply right-side X8340-S02R-...**

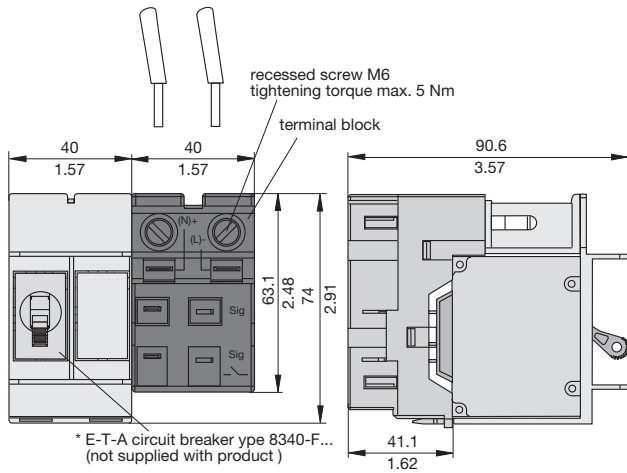

**Distribution rail, shown with power supply left-side X8340-S02L-...**

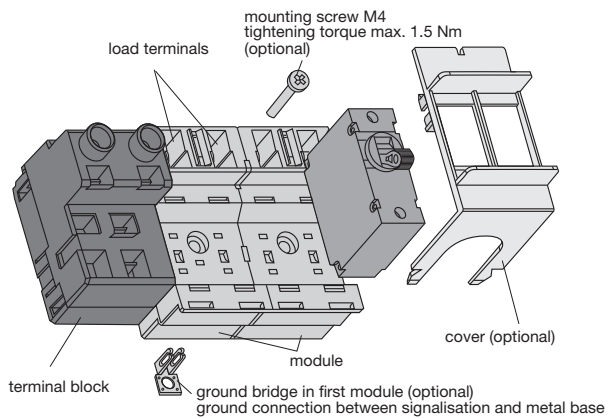

## Internal connection diagram

### Group signalling

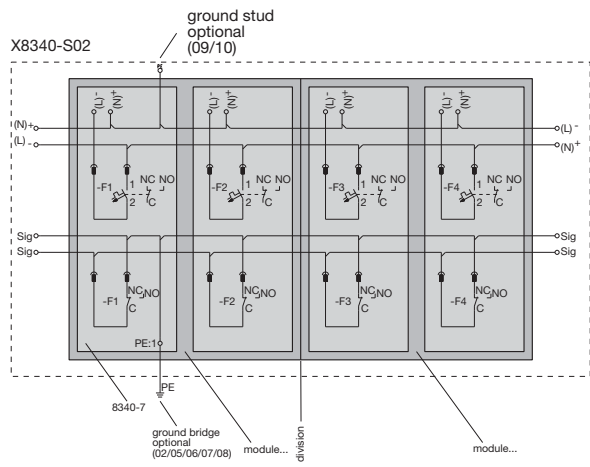

### Single signalling

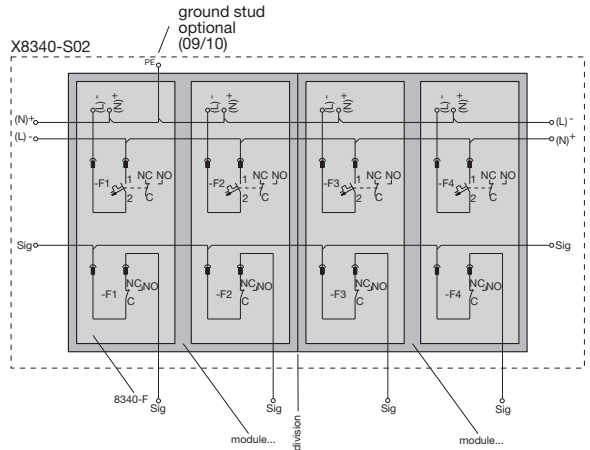

## Internal connection diagrams

### Load output terminal protected against reverse polarity

(set: 4 moulded sleeves, 8 blade terminals 6.3 x 0.8 mm)

**X 222 847 01** for cable cross section 0.7...2.0 mm<sup>2</sup>

**X 222 625 01** for cable cross section 2.5...4.0 mm<sup>2</sup>

**X 222 848 01** for cable cross section 4.0...6.0 mm<sup>2</sup>

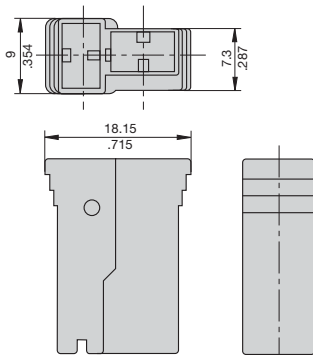

This is a metric design and millimeter dimensions take precedence ( $\frac{mm}{inch}$ )

All dimensions without tolerances are for reference only. In the interest of improved design, performance and cost effectiveness the right to make changes in these specifications without notice is reserved. Product markings may not be exactly as the ordering codes. Errors and omissions excepted.