

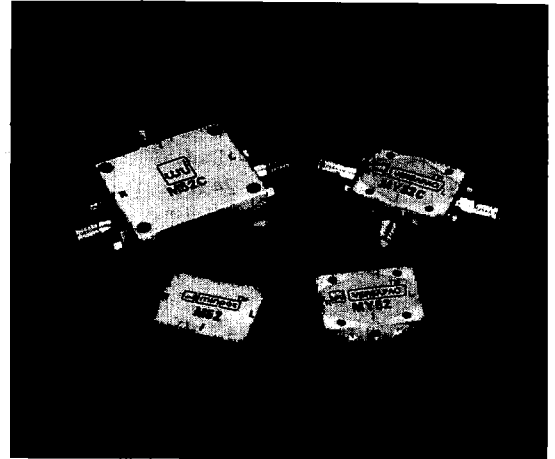

# M52 / M52C MY52 / MY52C

## TRIPLE BALANCED MIXER

- ◆ LO } 2.0 TO 24.0 GHz
- RF }
- ◆ IF 0.1 TO 5.0 GHz
- ◆ LO DRIVE +10 dBm (NOMINAL)
- ◆ HIGH COMPRESSION POINT
- ◆ VERY WIDE BANDWIDTH
- ◆ MIL-M-28837 EQUIVALENT LEVEL SCREENING AVAILABLE



### Outline Drawings

M52  
(MINPAC)

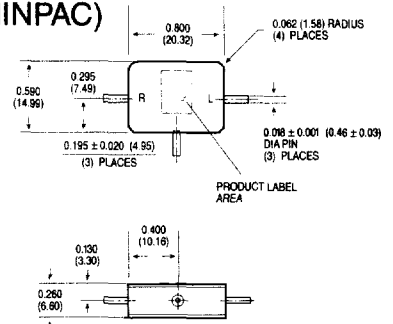

DIMENSIONS ARE IN INCHES (MILLIMETERS) ± 0.015 (0.38) UNLESS OTHERWISE SPECIFIED

M52C  
(CONNECTORIZED)

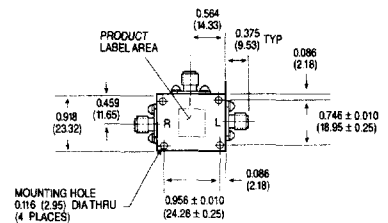
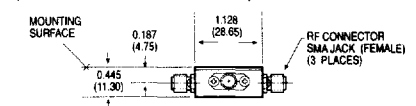

DIMENSIONS ARE IN INCHES (MILLIMETERS) ± 0.015 (0.38) UNLESS OTHERWISE SPECIFIED

### Guaranteed Specifications<sup>1,2</sup>

Characteristics	Typ.	+25°C	-54°C to +85°C	Test Conditions
SSB Conversion Loss and SSB Noise Figure (Max.)	7.5 dB	9.5 dB	10.0 dB	RF = 8 to 18 GHz LO = 8 to 18 GHz IF = 0.1 to 4.0 GHz
	8.0 dB	10.0 dB	10.5 dB	RF = 2 to 8 GHz LO = 2 to 8 GHz IF = 1.0 to 4.0 GHz
	8.5 dB	10.5 dB	11.0 dB	RF = 2 to 18 GHz LO = 2 to 18 GHz IF = 0.1 to 5.0 GHz
	9.5 dB	12.5 dB	13.0 dB	RF = 18 to 24 GHz LO = 13 to 24 GHz IF = 0.1 to 5.0 GHz
Isolation (Min.) L - R  L - I	18 dB	15 dB	13 dB	LO = 2 to 24 GHz
	25 dB	20 dB	18 dB	LO = 4 to 19 GHz
	30 dB	22 dB	20 dB	LO = 2 to 20 GHz
	20 dB	15 dB	13 dB	LO = 20 to 24 GHz
Conversion Compression	1.0 dB			f <sub>R</sub> Level +5.0 dBm f <sub>L</sub> Level +10.0 dBm
Third-Order Input Intercept Point	+16 dBm			RF <sub>1</sub> 3.75 GHz -6 dBm RF <sub>2</sub> 3.76 GHz -6 dBm LO 4.0 GHz +10 dBm
	+16 dBm			RF <sub>1</sub> 13.00 GHz -6 dBm RF <sub>2</sub> 13.01 GHz -6 dBm LO 11.0 GHz +10 dBm
	+13 dBm			RF <sub>1</sub> 20.00 GHz -6 dBm RF <sub>2</sub> 20.01 GHz -6 dBm LO 24.0 GHz +10 dBm

Notes:

1. Measured in a 50-ohm system with nominal LO drive and downconverter application only unless otherwise specified.
2. Typical values are measured at 25°C and are not guaranteed. Typical performance applies to the MINPAC™ model and does not necessarily reflect the performance of the VERSAPAC model.

### Absolute Maximum Ratings

Operating Temperature.....-54°C to +100°C  
 Storage Temperature.....-65°C to +100°C  
 Peak Input Power.....+26 dBm max. at +25°C, +22 dBm max. at +100°C

Weight M52: 12 grams (0.42 oz.) max. M52C: 40 grams (1.41 oz.) max.  
 MY52: 12 grams (0.42 oz.) max. MY52C: 18 grams (0.63 oz.) max.

# Outline Drawings

## MY52 (VERSAPAC)

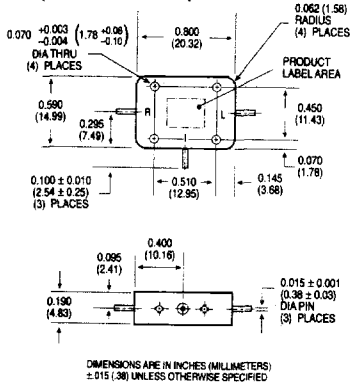

## MY52C (CONNECTORIZED)

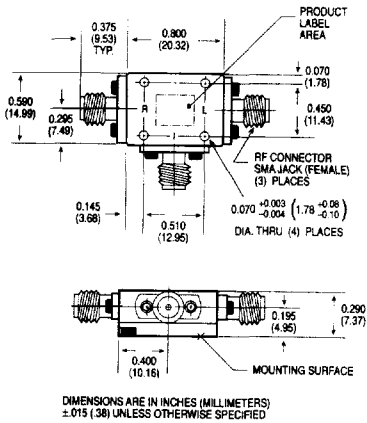

# Typical Performance at 25°C \*

## Drive Level

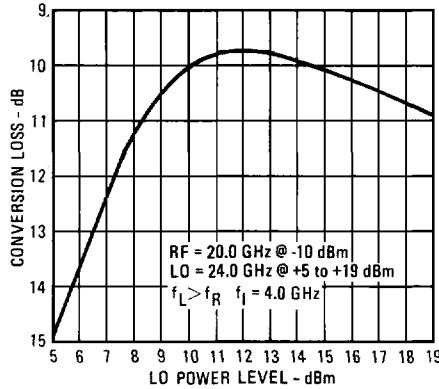
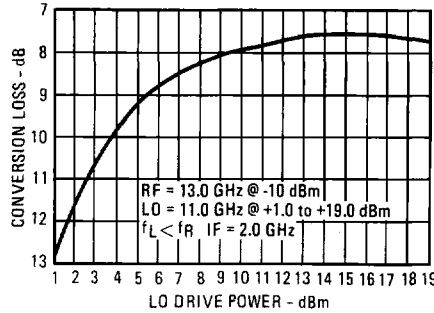
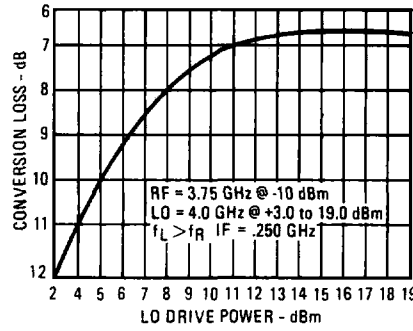

**Drive Level:** The maximum recommended drive level is +17 dBm.

## Conversion Loss vs. Frequency

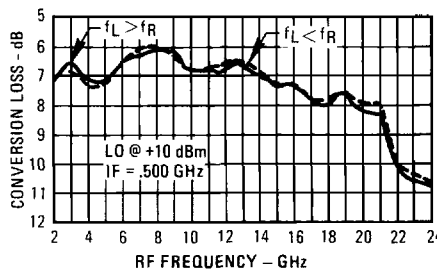
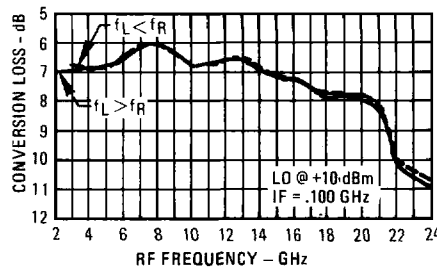

# WJ-M52/M52C/MY52/MY52C

## Conversion Loss vs. Frequency

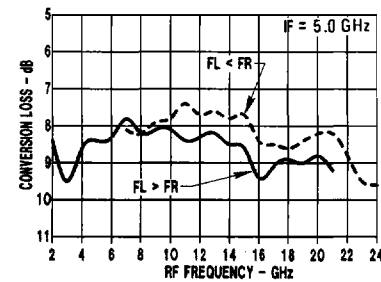
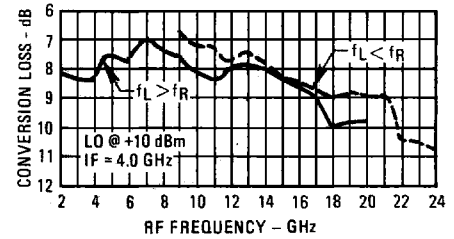
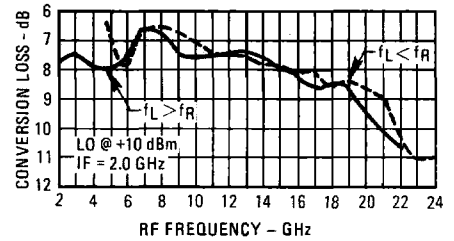
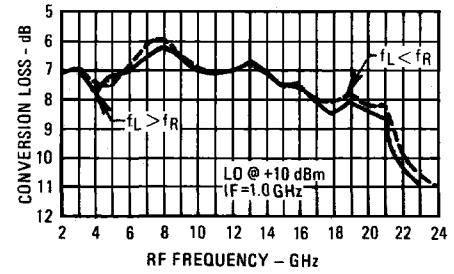

## Isolation vs. Frequency

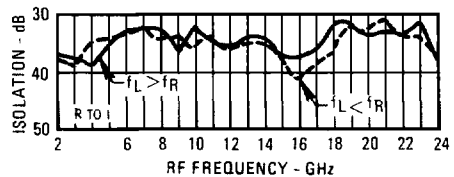
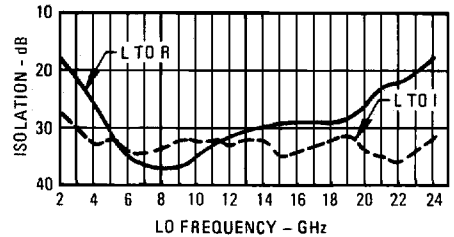

\*Typical performance applies to the MINPAC™ model and does not necessarily reflect the performance of the VERSAPAC® model.

# Typical Performance at 25°C \*

WJ-M52/M52C/MY52/MY52C

## Third-Order Intercept Input

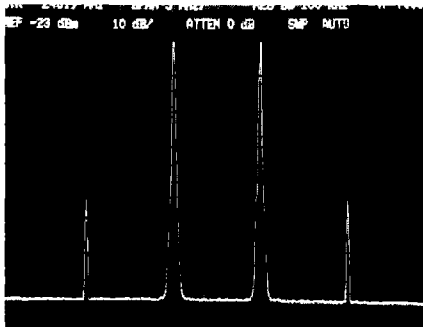

$f_R = 3.75, 3.76 @ -6 \text{ dBm}$   
 LO = 4.0 GHz @ +10 dBm

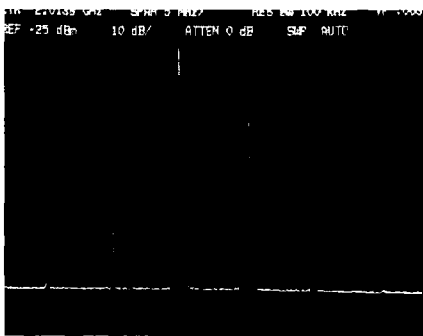

$f_R = 13 \text{ GHz}, 13.01 \text{ GHz} @ -6 \text{ dBm}$   
 LO = 11.0 GHz @ +10 dBm

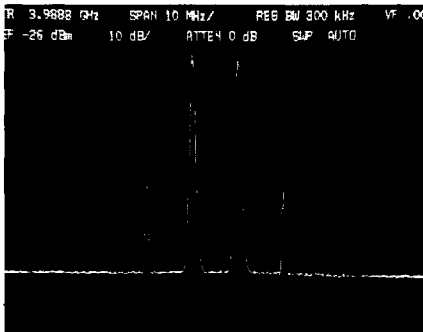

$f_R = 20 \text{ GHz}, 20.01 \text{ GHz} @ -6 \text{ dBm}$   
 LO = 24 GHz @ +10 dBm

## L-Port VSWR

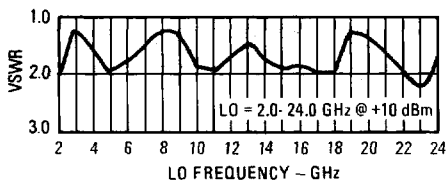

## R-Port VSWR

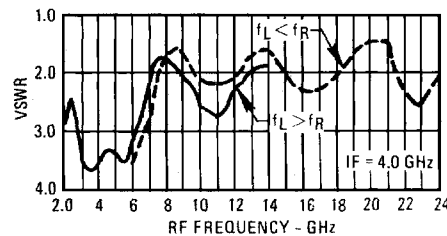
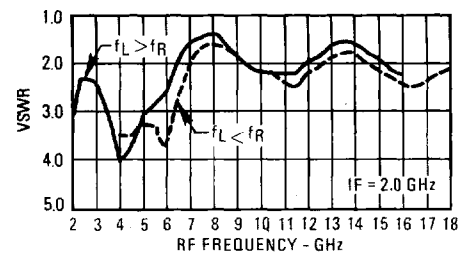
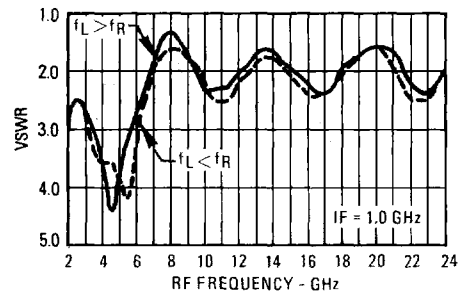
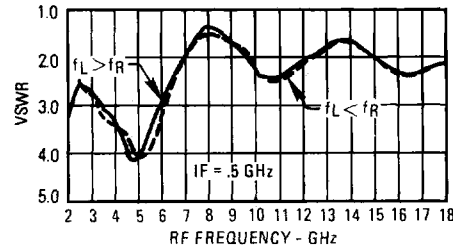
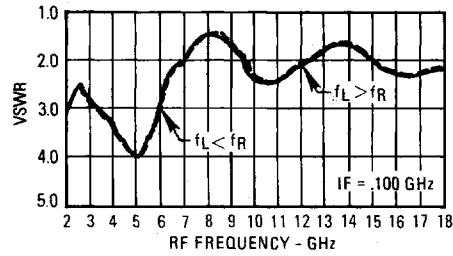

## I-Port VSWR

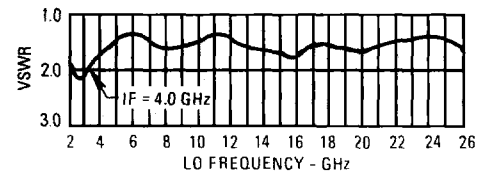
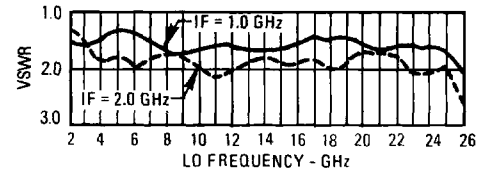
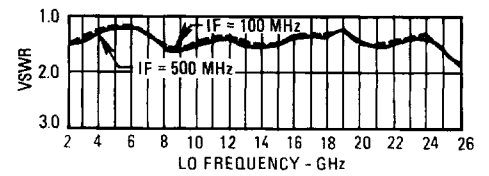

\*Typical performance applies to the MINPAC™ model and does not necessarily reflect the performance of the VERSAPAC® model.

Typical Performance at 25°C\*

WJ-M52/M52C/MY52/MY52C

Harmonics of $f_L$	R - Port	I - Port	Test Conditions
$f_L$	-8 dBm	-16 dBm	$f_L = 2$ GHz at +10 dBm
$2 f_L$	-27 dBm	-18 dBm	
$3 f_L$	-21 dBm	-34 dBm	
$4 f_L$	-31 dBm	-27 dBm	
$5 f_L$	-29 dBm	-41 dBm	
$6 f_L$	-49 dBm	-38 dBm	
$7 f_L$	-34 dBm	-46 dBm	
$8 f_L$	-49 dBm	-61 dBm	
$9 f_L$	-41 dBm	-53 dBm	
$10 f_L$	-54 dBm	-58 dBm	
$11 f_L$	-50 dBm	-58 dBm	
$f_L$	-24 dBm	-24 dBm	$f_L = 6$ GHz at +10 dBm
$2 f_L$	-25 dBm	-30 dBm	
$3 f_L$	-27 dBm	-32 dBm	
$f_L$	-23 dBm	-22 dBm	$f_L = 11$ GHz at +10 dBm
$2 f_L$	-38 dBm	-41 dBm	

Single Tone Im $f_L f_R$	Typical Suppression	Test Conditions
$f_L f_R$		$f_L = 2$ GHz at +10 dBm $f_R = 3.25$ GHz at -10 dBm
1 x 1	0 dB	
1 x 2	39 dB	
1 x 3	48 dB	
2 x 1	33 dB	
2 x 2	40 dB	
3 x 1	14 dB	
3 x 2	47 dB	
3 x 3	65 dB	
4 x 1	45 dB	
4 x 2	43 dB	
5 x 1	19 dB	
5 x 3	62 dB	
6 x 2	42 dB	
7 x 3	55 dB	
$f_L f_R$		$f_L = 4.1$ GHz at +10 dBm $f_R = 6.0$ GHz at -10 dBm
1 x 1	0 dB	
1 x 2	56 dB	
2 x 1	31 dB	
2 x 2	48 dB	
3 x 1	16 dB	
3 x 2	51 dB	
3 x 3	57 dB	
4 x 1	43 dB	
4 x 2	44 dB	
5 x 3	54 dB	
7 x 3	67 dB	

\*Typical performance applies to the MINPAC™ model and does not necessarily reflect the performance of the VERSAPAC® models.