

FEATURES

- 5V and 3.3V power supply options
- 300ps typical propagation delay
- Low power
- Differential PECL output
- PNP TTL input for minimal loading
- Flow-through pinouts
- ESD protection of 2000V
- Available in 8-pin SOIC package

DESCRIPTION

The SY10/100ELT20V is a single TTL-to-differential PECL translators. Because PECL (Positive ECL) levels are used, either +5V or +3.3V and ground are required. The small outline 8-lead SOIC package and low skew single gate design make the ELT20V ideal for applications that require the translation of a clock or data signal where minimal space, low power, and low cost are critical.

The ELT20V is available in both ECL standards: the 10ELT is compatible with positive ECL 10H logic levels, while the 100ELT is compatible with positive ECL 100K logic levels.

PIN CONFIGURATION/BLOCK DIAGRAM

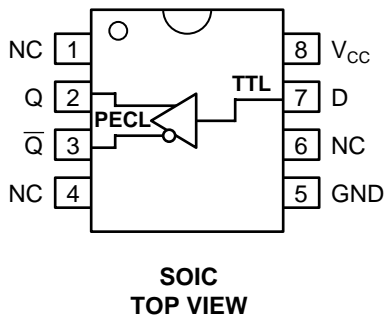

PIN NAMES

Pin	Function
Q	Differential PECL Output
D	TTL Input
V _{CC}	+5V/+3.3V Supply
GND	Ground

ABSOLUTE MAXIMUM RATINGS⁽¹⁾

Symbol	Parameter	Value	Unit
V _{CC}	Power Supply Voltage	-0.5 to +7.0	V
V _I	TTL Input Voltage	-0.5 to V _{CC}	V
I _I	TTL Input Current	-30 to +5.0	mA
I _{OUT}	PECL Output Current -Continuous -Surge	50 100	mA
T _{store}	Storage Temperature	-65 to +150	°C
T _A	Operating Temperature	-40 to +85	°C

TRUTH TABLE

D	Q	\bar{Q}
H	H	L
L	L	H
Open	H	L

NOTE:

- Permanent device damage may occur if ABSOLUTE MAXIMUM RATINGS are exceeded. This is a stress rating only and functional operation is not implied at conditions other than those detailed in the operational sections of this data sheet. Exposure to ABSOLUTE MAXIMUM RATING conditions for extended periods may affect device reliability.

DC ELECTRICAL CHARACTERISTICS

V_{CC} = +3.0V to +5.5V

Symbol	Parameter	T _A = -40°C		T _A = 0°C		T _A = +25°C			T _A = +85°C		Unit	Condition
		Min.	Max.	Min.	Max.	Min.	Typ.	Max.	Min.	Max.		
I _{CC}	Power Supply Current	—	20	—	20	—	—	20	—	20	mA	—

TTL DC ELECTRICAL CHARACTERISTICS

V_{CC} = +3.0V to +5.5V

Symbol	Parameter	T _A = -40°C		T _A = 0°C		T _A = +25°C			T _A = +85°C		Unit	Condition
		Min.	Max.	Min.	Max.	Min.	Typ.	Max.	Min.	Max.		
V _{IH}	Input HIGH Voltage	2.0	—	2.0	—	2.0	—	—	2.0	—	V	—
V _{IL}	Input LOW Voltage	—	0.8	—	0.8	—	—	0.8	—	0.8	V	—
I _{IH}	Input HIGH Current	—	20	—	20	—	—	20	—	20	μA	V _{IN} = 2.7V V _{IN} = V _{CC}
I _{IL}	Input LOW Current	—	-0.2	—	-0.2	—	—	-0.2	—	-0.2	mA	V _{IN} = 0.5V
V _{IK}	Input Clamp Voltage	—	-1.2	—	-1.2	—	—	-1.2	—	-1.2	V	I _{IN} = -18mA

PECL DC ELECTRICAL CHARACTERISTICS

V_{CC} = +3.0V to +5.5V

Symbol	Parameter	T _A = -40°C		T _A = 0°C		T _A = +25°C			T _A = +85°C		Unit	Condition	
		Min.	Max.	Min.	Max.	Min.	Typ.	Max.	Min.	Max.			
V _{OH}	Output HIGH Voltage ⁽¹⁾	10ELT	3920	4110	3980	4160	4020	—	4190	4090	4280	mV	
		100ELT	3915	4120	3975	4120	3975	—	4120	3975	4120		
		100ELT	3915	4120	3975	4120	3975	—	4120	3975	4120		
V _{OL}	Output LOW Voltage ⁽¹⁾	10ELT	3050	3350	3050	3370	3050	—	3370	3050	3405	mV	
		100ELT	3170	3445	3190	3380	3190	—	3380	3190	3380		
		100ELT	3170	3445	3190	3380	3190	—	3380	3190	3380		

NOTES:

- These values are for V_{CC} = 5.0V. Level Specifications will vary 1:1 with V_{CC}.

AC ELECTRICAL CHARACTERISTICS⁽¹⁾

VCC = +3.0V to +5..5V

Symbol	Parameter	TA = -40°C		TA = 0°C		TA = +25°C			TA = +85°C		Unit	Condition
		Min.	Max.	Min.	Max.	Min.	Typ.	Max.	Min.	Max.		
tPLH tPHL	Propagation Delay ⁽¹⁾	100	600	100	600	100	—	600	100	600	ps	50Ω to VCC – 2.0V
tskpp	Part-to-Part Skew ⁽²⁾	—	500	—	500	—	—	500	—	500	ps	50Ω to VCC – 2.0V
fMAX	Maximum Input Frequency	350	—	350	—	350	—	—	350	—	MHz	50Ω to VCC – 2.0V
tr tf	Output Rise/Fall Time (20% to 80%)	200	500	200	500	200	—	500	200	500	ps	50Ω to VCC – 2.0V

NOTE:

1. Input Rise Time < 1.0ns.
2. Guaranteed by design. Not tested in production.

PRODUCT ORDERING INFORMATION

Ordering Code	Package Type	Operating Range	Vcc Range (V)
SY10ELT20ZC	Z8-1	Commercial	+3.0V to +5.5V
SY10ELT20ZCTR	Z8-1	Commercial	+3.0V to +5.5V
SY100ELT20ZC	Z8-1	Commercial	+3.0V to +5.5V
SY100ELT20ZCTR	Z8-1	Commercial	+3.0V to +5.5V

8 LEAD PLASTIC SOIC (Z8-1)

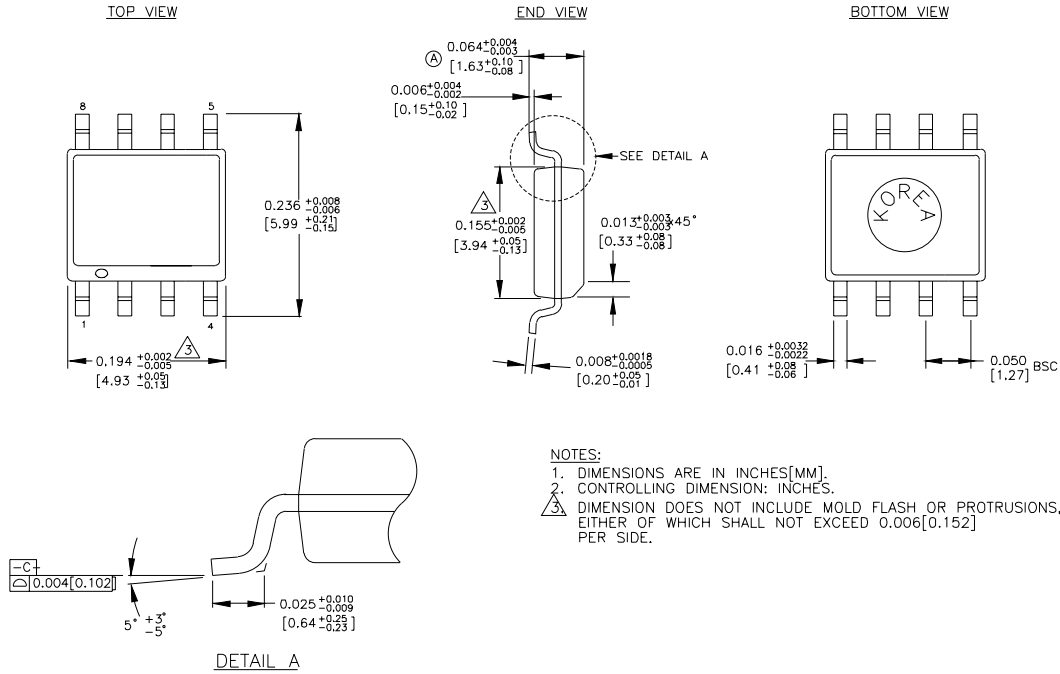

NOTES:
 1. DIMENSIONS ARE IN INCHES[MM].
 2. CONTROLLING DIMENSION: INCHES.
 ⚠ DIMENSION DOES NOT INCLUDE MOLD FLASH OR PROTRUSIONS, EITHER OF WHICH SHALL NOT EXCEED 0.006[0.152] PER SIDE.

MICREL-SYNERGY 3250 SCOTT BOULEVARD SANTA CLARA CA 95054 USA

TEL + 1 (408) 980-9191 FAX + 1 (408) 914-7878 WEB <http://www.synergyssemi.com> <http://www.micrel.com>

This information is believed to be accurate and reliable, however no responsibility is assumed by Micrel for its use nor for any infringement of patents or other rights of third parties resulting from its use. No license is granted by implication or otherwise under any patent or patent right of Micrel Inc.