

Datasheet

1. Features

- Dual ADC with 8-bit Resolution
- 500 Msp/s Sampling Rate per Channel, 1 Gsp/s in interleaved Mode
- Single or 1:2 Demultiplexed Output
- LVDS Output Format (100Ω)
- 500 mVpp Analog Input (Differential Only)
- Differential or Single-ended 50Ω PECL/LVDS Compatible Clock Inputs
- Power Supply: 3.3V (Analog), 3.3V (Digital), 2.25V (Output)
- LQFP144 or LQFP-ep 144L Green packages
- Temperature Range:
 - 0°C < T_{amb} < 70°C (Commercial Grade)
 - -40°C < T_{amb} < 85°C (Industrial Grade)
- 3-wire Serial Interface
 - 16-bit Data, 3-bit Address
 - 1:2 or 1:1 Output Demultiplexer Ratio Selection
 - Full or Partial Standby Mode
 - Analog Gain (±1.5 dB) Digital Control
 - Input Clock Selection
 - Analog Input Switch Selection
 - Binary or Gray Logical Outputs
 - Synchronous Data Ready Reset
 - Data Ready Delay Adjustable on Both Channels
 - interleaving Functions:
 - Offset and Gain (Channel to Channel) Calibration
 - Digital Fine SDA (Fine Sampling Delay Adjust) on One Channel
 - Internal Static or Dynamic Built-In Test (BIT)

2. Performance

- Low Power Consumption: 0.7W per Channel
- Power Consumption in Standby Mode: 120 mW
- 1 GHz Full Power Input Bandwidth (-3 dB)
- SNR = 45 dB Typ (7.2 ENOB), THD = -53 dBc, SFDR = -56 dBc at F_s = 500 Msp/s
F_{in} = 250 MHz
- 2-tone IMD3: -54 dBc (249 MHz, 251 MHz) at 500 Msp/s
- DNL = 0.25 LSB, INL = 0.5 LSB
- Low Bit Error Rate (10⁻¹⁸) at 500 Msp/s

3. Application

- Digital Oscilloscopes
- Communication Receivers (I/Q)
- Direct RF Down Conversion
- High Speed Data Acquisition
- Radar/ECM

Visit our website: www.e2v.com
for the latest version of the datasheet

4. Description

The AT84AD004B is a monolithic dual 8-bit analog-to-digital converter, offering low 1.4W power consumption and excellent digitizing accuracy. It integrates dual on-chip track/holds that provide an enhanced dynamic performance with a sampling rate of up to 500 Msps and an input frequency bandwidth of 1 GHz. The dual concept, the integrated demultiplexer and the easy interleaving mode make this device user-friendly for all dual channel applications, such as direct RF conversion or data acquisition. The *smart* function of the 3-wire serial interface eliminates the need for external components, which are usually necessary for gain and offset tuning and setting of other parameters, leading to space and power reduction as well as system flexibility.

5. Functional Description

The AT84AD004B is a dual 8-bit 500 Msps ADC based on advanced high-speed BiCMOS technology.

Each ADC includes a front-end analog multiplexer followed by a Sample and Hold (S/H), and an 8-bit flash-like architecture core analog-to-digital converter. The output data is followed by a switchable 1:1 or 1:2 demultiplexer and LVDS output buffers (100Ω).

Two over-range bits are provided for adjustment of the external gain control on each channel.

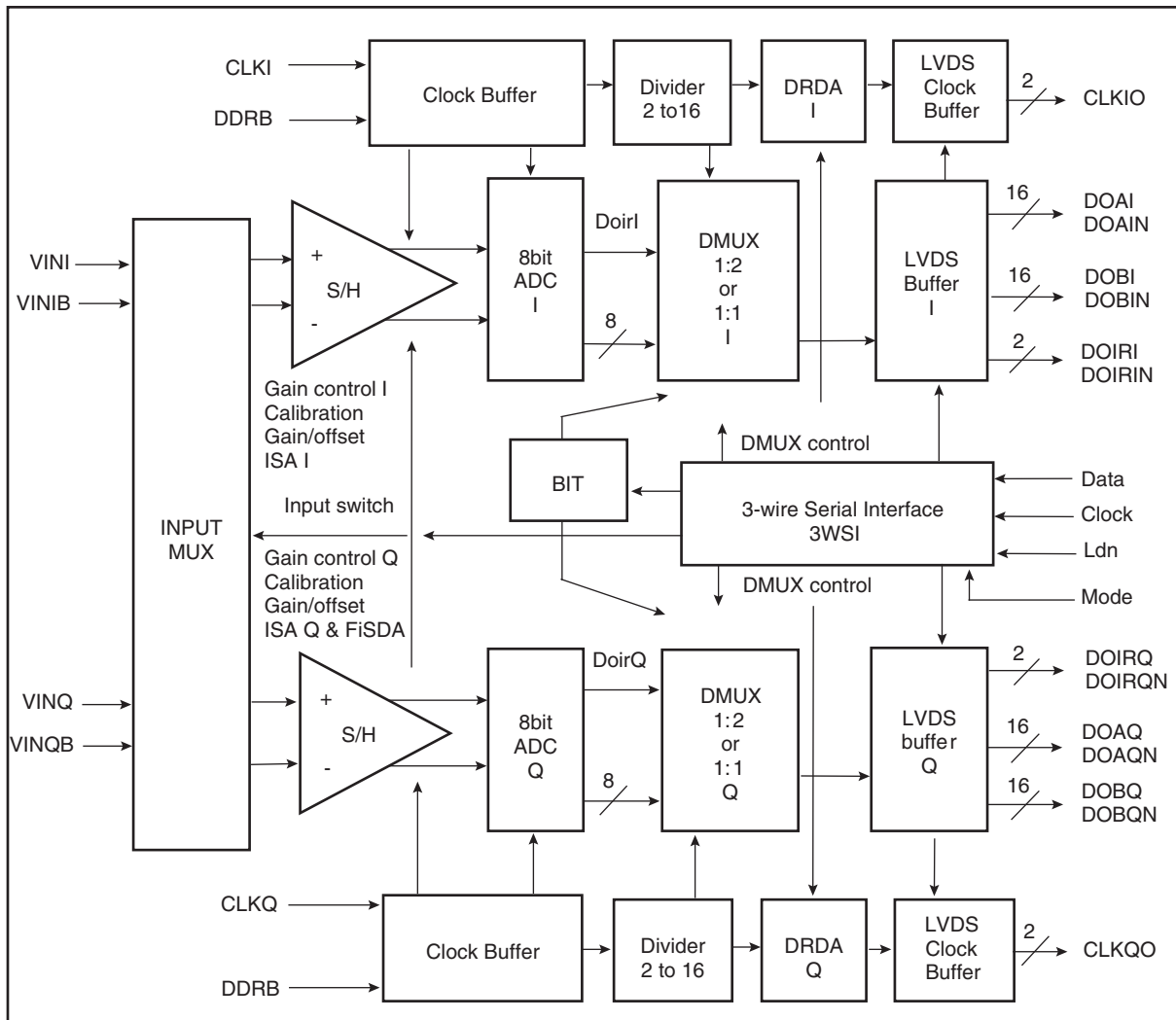
A 3-wire serial interface (3-bit address and 16-bit data) is included to provide several adjustments:

- Analog input range adjustment (± 1.5 dB) with 8-bit data control using a 3-wire bus interface (steps of 0.18 dB)
- Analog input switch: both ADCs can convert the same analog input signal I or Q
- Gray or binary encoder output. Output format: DMUX 1:1 or 1:2 with control of the output frequency on the data ready output signal
- Partial or full standby on channel I or channel Q
- Clock selection:
 - Two independent clocks: CLKI and CLKQ
 - One master clock (CLKI) with the same phase for channel I and channel Q
 - One master clock but with two phases (CLKI for channel I and CLKIB for channel Q)
- ISA: Internal Settling Adjustment on channel I and channel Q
- FiSDA: Fine Sampling Delay Adjustment on channel Q
- Adjustable Data Ready Output Delay on both channels
- Test mode: decimation mode (by 16), Built-in Test

A calibration phase is provided to set the two DC offsets of channel I and channel Q close to code 127.5 and calibrate the two gains. The offset and gain error can also be set externally via the 3-wire serial interface.

The AT84AD004B operates in fully differential mode from the analog inputs up to the digital outputs. The AT84AD004B features a full-power input bandwidth of 1 GHz.

Figure 5-1. Simplified Block Diagram



6. Typical Applications

Figure 6-1. Satellite Receiver Application

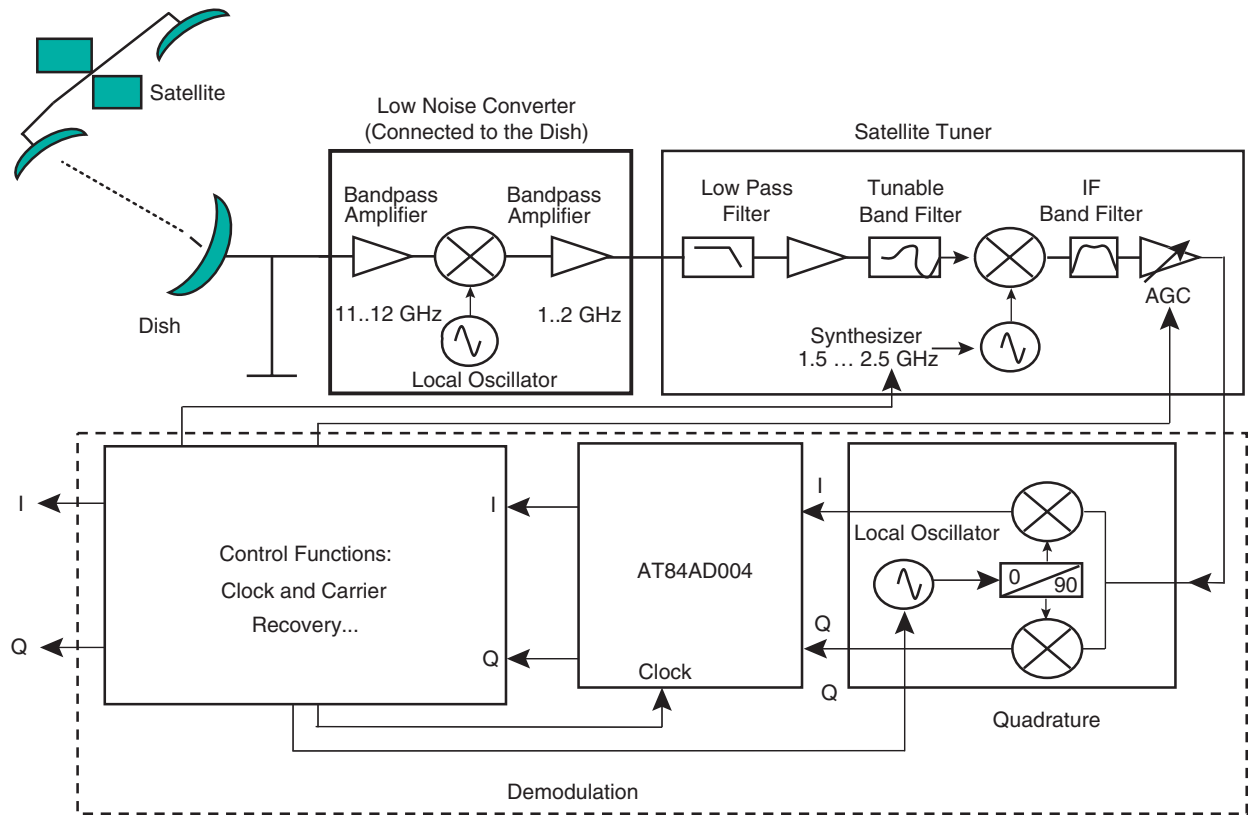
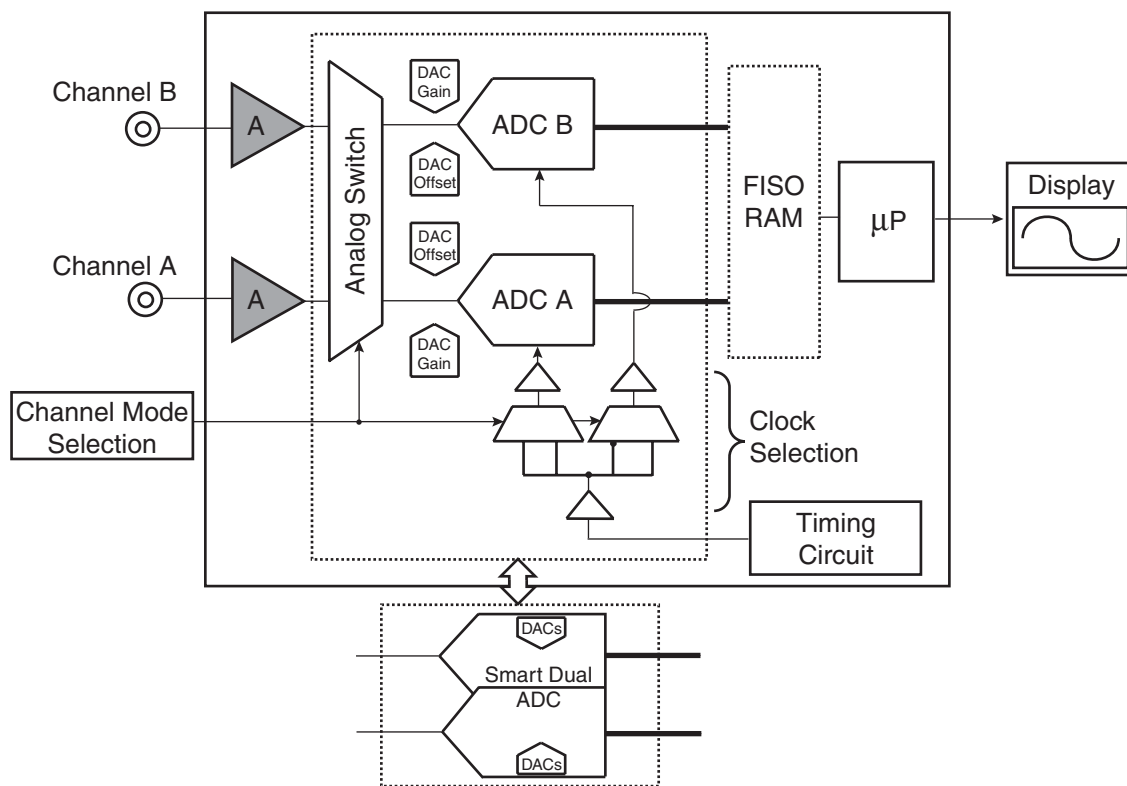


Figure 6-2. Dual Channel Digital Oscilloscope Application



6.1 Absolute Maximum Ratings

Table 6-1. Absolute Maximum Ratings

Parameter	Symbol	Value	Unit
Analog positive supply voltage	V_{CCA}	3.6	V
Digital positive supply voltage	V_{CCD}	3.6	V
Output supply voltage	V_{CCO}	3.6	V
Maximum difference between V_{CCA} and V_{CCD}	V_{CCA} to V_{CCD}	± 0.8	V
Minimum V_{CCO}	V_{CCO}	1.6	V
Analog input voltage	V_{INI} or V_{INIB} V_{INQ} or V_{INQB}	1/-1	V
Digital input voltage	V_D	-0.3 to $V_{CCD} + 0.3$	V
Clock input voltage	V_{CLK} or V_{CLKB}	-0.3 to $V_{CCD} + 0.3$	V
Maximum difference between V_{CLK} and V_{CLKB}	$V_{CLK} - V_{CLKB}$	-2 to 2	V
Maximum junction temperature	T_J	125	$^{\circ}\text{C}$
Storage temperature	T_{stg}	-65 to 150	$^{\circ}\text{C}$
Lead temperature (soldering 10s)	T_{leads}	300	$^{\circ}\text{C}$

Note: Absolute maximum ratings are limiting values (referenced to GND = 0V), to be applied individually, while other parameters are within specified operating conditions. Long exposure to maximum ratings may affect device reliability.

6.2 Recommended Conditions of Use

Table 6-2. Recommended Conditions of Use

Parameter	Symbol	Comments	Recommended Value	Unit
Analog supply voltage	V_{CCA}		3.3	V
Digital supply voltage	V_{CCD}		3.3	V
Output supply voltage	V_{CCO}		2.25	V
Differential analog input voltage (full-scale)	$V_{INI} - V_{INIB}$ or $V_{INQ} - V_{INQB}$		500	mVpp
Differential clock input level	V_{inclk}		600	mVpp
Internal Settling Adjustment (ISA) with a 3-wire serial interface for channel I and channel Q	ISA		0	ps
Operating temperature range	$T_{Ambient}$	Commercial grade Industrial grade	$0 < T_{amb} < 70$ $-40 < T_{amb} < 85$	°C

7. Electrical Operating Characteristics

Unless otherwise specified:

- $V_{CCA} = 3.3V$; $V_{CCD} = 3.3V$; $V_{CCO} = 2.25V$
- $V_{INI} - V_{INIB}$ or $V_{INQ} - V_{INQB} = 500$ mVpp full-scale differential input
- LVDS digital outputs (100Ω)
- T_{amb} (typical) = $25^{\circ}C$
- Full temperature range: $0^{\circ}C < T_{amb} < 70^{\circ}C$ (commercial grade)

Table 7-1. Electrical Operating Characteristics in Nominal Conditions

Parameter	Symbol	Min	Typ	Max	Unit
Resolution			8		Bits
Power Requirements					
Positive supply voltage					
- Analog	V_{CCA}	3.15	3.3	3.45	V
- Digital	V_{CCD}	3.15	3.3	3.45	V
Output digital (LVDS) and serial interface	V_{CCO}	2.0	2.25	2.5	V
Supply current (typical conditions)					
- Analog	I_{CCA}		150	180	mA
- Digital	I_{CCD}		230	275	mA
- Output	I_{CCO}		100	120	mA

Table 7-1. Electrical Operating Characteristics in Nominal Conditions (Continued)

Parameter	Symbol	Min	Typ	Max	Unit
Supply current (1:2 DMUX mode) - Analog - Digital - Output	I_{CCA} I_{CCD} I_{CCO}		150 260 175	180 310 210	mA mA
Supply current (2 input clocks, 1:2 DMUX mode) - Analog - Digital - Output	I_{CCA} I_{CCD} I_{CCO}		150 290 180	180 350 215	mA
Supply current (1 channel only, 1:1 DMUX mode) - Analog - Digital - Output	I_{CCA} I_{CCD} I_{CCO}		80 160 55	95 190 65	mA mA mA
Supply current (1 channel only, 1:2 DMUX mode) - Analog - Digital - Output	I_{CCA} I_{CCD} I_{CCO}		80 170 90	95 205 110	mA mA mA
Supply current (full standby mode) - Analog - Digital - Output	I_{CCA} I_{CCD} I_{CCO}		12 24 3	20 39 7	mA mA mA
Nominal dissipation (1 clock, 1:1 DMUX mode, 2 channels)	P_D		1.4	1.7	W
Nominal dissipation (full standby mode)	stbpd		120		mW
Analog Inputs					
Full-scale differential analog input voltage to obtain full-scale with no gain adjust (mode 0)	$V_{INi} - V_{INiB}$ or $V_{INQ} - V_{INQB}$	450	500	550	mV mV
Analog input capacitance I and Q	C_{IN}			2	pF
Full power input bandwidth (-3 dB)	FPBW		1.0		GHz
Gain flatness (-0.5 dB)			400		MHz
Clock Input					
Logic compatibility for clock inputs and DDRB Reset (pins 124,125,126,127,128,129)		PECL/ECL/LVDS			
PECL/LVDS clock inputs and DDRB input voltages ($V_{CLKI/IN}$ or $V_{CLKQ/QN}$) Differential logical level	$V_{IL} - V_{IH}$		600		mV
Clock input and DDRB input power level		-9	0	6	dBm
Clock input capacitance			2		pF
Digital Outputs					

Table 7-1. Electrical Operating Characteristics in Nominal Conditions (Continued)

Parameter	Symbol	Min	Typ	Max	Unit
Logic compatibility for digital outputs (depending on the value of V_{CCO})	LVDS				
Differential output voltage swings (assuming $V_{CCO} = 2.25V$)	V_{OD}	220	270	350	mV
Output levels (assuming $V_{CCO} = 2.25V$) 100 Ω differentially terminated					
Logic 0 voltage	V_{OL}	1.0	1.1	1.2	V
Logic 1 voltage	V_{OH}	1.25	1.35	1.48	V
Output offset voltage (assuming $V_{CCO} = 2.25V$) 100 Ω differentially terminated	V_{OS}	1125	1250	1340	mV
Output impedance	R_O		50		Ω
Output current (shorted output)				12	mA
Output current (grounded output)			30		mA
Output level drift with temperature			1.3		mV/ $^{\circ}C$
Digital Input (Serial Interface)					
Maximum clock frequency (input clk)	Fclk			50	MHz
Input logical level 0 (clk, mode, data, ldn)		-0.4	0	0.4	V
Input logical level 1 (clk, mode, data, ldn)		$V_{CCO} - 0.4$	$V_{CCO} - 0.4$	$V_{CCO} + 0.4$	V
Output logical level 0 (cal)		-0.4	0	0.4	V
Output logical level 1 (cal)		$V_{CCO} - 0.4$	V_{CCO}	$V_{CCO} + 0.4$	V
Maximum output load (cal)				15	pF

Note: The gain setting is 0 dB, one clock input, no standby mode [full power mode], 1:1 DMUX, calibration off.

Table 7-2. Electrical Operating Characteristics

Parameter	Symbol	Min	Typ	Max	Unit
DC Accuracy					
No missing code		Guaranteed over specified temperature range			
Differential non-linearity	DNL		0.25	0.6	LSB
Integral non-linearity	INL		0.5	1	LSB
Gain error (single channel I or Q) with calibration		-2	0	2	%
Input offset matching (single channel I or Q) with calibration		-2	0	2	LSB
Gain error drift against temperature			0.062		LSB/ $^{\circ}C$
Gain error drift against V_{CCA}			0.064		LSB/mV
Mean output offset code with calibration		126	127.5	129	LSB

Table 7-2. Electrical Operating Characteristics

Parameter	Symbol	Min	Typ	Max	Unit
Transient Performance					
Bit Error Rate Fs = 500 Msps Fin = 250 MHz	BER		10 ⁻¹⁸		Error/ sample
ADC settling time channel I or Q (between 10% - 90% of output response) V _{Ini} - V _{iniB} = 500 mVpp	TS		170		ps

Note: The gain setting is 0 dB, two clock inputs, no standby mode [full power mode], 1:2 DMUX, calibration on.

Table 7-3. AC Performance

Parameter	Symbol	Min	Typ	Max	Unit
AC Performance					
Signal-to-noise Ratio					
Fs = 500 Msps Fin = 20 MHz	SNR	44	46		dBc
Fs = 500 Msps Fin = 250 MHz		43	45		dBc
Fs = 500 Msps Fin = 500 MHz		42	44		dBc
Effective Number of Bits					
Fs = 500 Msps Fin = 20 MHz	ENOB	7	7.4		Bits
Fs = 500 Msps Fin = 250 MHz		6.9	7.2		Bits
Fs = 500 Msps Fin = 500 MHz		6.7	7.0		Bits
Total Harmonic Distortion (First 9 Harmonics)					
Fs = 500 Msps Fin = 20 MHz	ITHDI	48	55		dBc
Fs = 500 Msps Fin = 250 MHz		47	53		dBc
Fs = 500 Msps Fin = 500 MHz		47	53		dBc
Spurious Free Dynamic Range					
Fs = 500 Msps Fin = 20 MHz	ISFDRI	50	57		dBc
Fs = 500 Msps Fin = 250 MHz		49	56		dBc
Fs = 500 Msps Fin = 500 MHz		49	56		dBc
Two-tone Inter-modulation Distortion (Single Channel)					
F _{IN1} = 249 MHz, F _{IN2} = 251 MHz at Fs = 500 Msps	IMD		-54		dBc
Phase matching using auto-calibration and FiSDA in interleaved mode (channel I and Q) Fin = 250 MHz Fs = 500 Msps	dφ	-0.7	0	0.7	°
Crosstalk channel I versus channel Q Fin = 250 MHz, Fs = 500 Msps ⁽²⁾	Cr		-55		dB

- Notes: 1. Differential input [-1 dBFS analog input level], gain setting is 0 dB, two input clock signals, no standby mode, 1:1 DMUX, ISA = 0 ps.
 2. Measured on the AT84AD004BTD-EB Evaluation Board

Table 7-4. AC Performances Over Full Industrial Temperature Range ($-40^{\circ}\text{C} < T_{\text{amb}} < 85^{\circ}\text{C}$)

Parameter	Symbol	Min	Typ	Max	Unit
AC Performance					
Signal-to-noise Ratio					
Fs = 500 Msps Fin = 500 MHz		41	44		dBc
Effective Number of Bits					
Fs = 500 Msps Fin = 500 MHz		6.5	7.0		Bits
Total Harmonic Distortion (First 9 Harmonics)					
Fs = 500 Msps Fin = 500 MHz		43	53		dBc
Spurious Free Dynamic Range					
Fs = 500 Msps Fin = 500 MHz		45	56		dBc

Table 7-5. AC Performances in Interleaved Mode

Parameter	Symbol	Min	Typ	Max	Unit
Interleaved Mode					
Maximum equivalent clock frequency $F_{\text{int}} = 2 \times F_{\text{s}}$ Where F_{s} = external clock frequency	F_{int}	1			Gsps
Minimum clock frequency	F_{int}		20		Msps
Differential non-linearity in interleaved mode	intDNL		0.25		LSB
Integral non-linearity in interleaved mode	intINL		0.5		LSB
Signal-to-noise Ratio in interleaved Mode					
Fint = 1 Gsps Fin = 20 MHz	iSNR		45		dBc
Fint = 1 Gsps Fin = 250 MHz			44		dBc
Effective Number of Bits in interleaved Mode					
Fint = 1 Gsps Fin = 20 MHz	iENOB		7.3		Bits
Fint = 1 Gsps Fin = 250 MHz			7.1		Bits
Total Harmonic Distortion in interleaved Mode					
Fint = 1 Gsps Fin = 20 MHz	liTHDI		54		dBc
Fint = 1 Gsps Fin = 250 MHz			53		dBc
Spurious Free Dynamic Range in interleaved Mode					

Table 7-5. AC Performances in Interleaved Mode

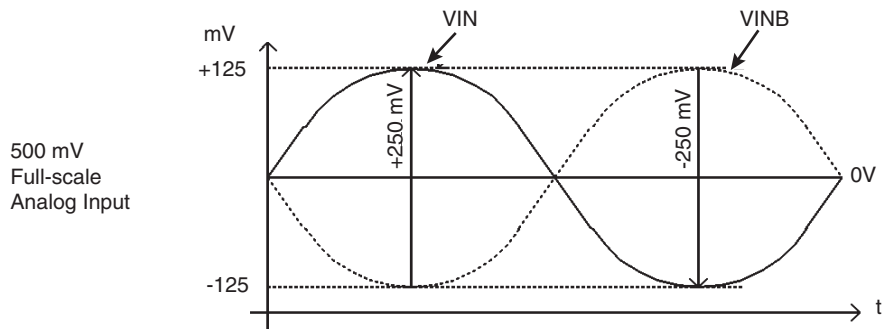
Parameter	Symbol	Min	Typ	Max	Unit
F _{int} = 1 Gsps Fin = 20 MHz	liSFDRl		56		dBc
F _{int} = 1 Gsps Fin = 250 MHz			55		dBc
Two-tone Inter-modulation Distortion (Single Channel) in interleaved Mode					
F _{IN1} = 249 MHz , F _{IN2} = 251 MHz at F _{int} = 1 Gsps	iIMD		-54		dBc

Note: One analog input on both cores, clock I samples the analog input on the rising and falling edges. The calibration phase is necessary. The gain setting is 0 dB, one input clock I, no standby mode, 1:1 DMUX, FiSDA adjustment.

Table 7-6. Switching Performances

Parameter	Symbol	Min	Typ	Max	Unit
Switching Performance and Characteristics - See "Timing Diagrams" on page 12.					
Maximum operating clock frequency	F _S	500			MspS
Minimum clock frequency (no transparent mode)	F _S		10		MspS
Minimum clock frequency (with transparent mode)				1	
Minimum clock pulse width [high] (No transparent mode)	TC1	0.4	1	50	ns
Minimum clock pulse width [low] (No transparent mode)	TC2	0.4	1	50	ns
Aperture delay: nominal mode with ISA & FiSDA	TA		1		ns
Aperture uncertainty	Jitter		0.4		ps (rms)
Data output delay between input clock and data	TDO		3.8		ns
Data Ready Output Delay	TDR		3		ns
Data Ready Reset to Data Ready	TRDR		2		ns
Data Output Delay with Data Ready	TD2		1/2 F _S +Tdrda		ps
Data Ready (CLKO) Delay Adjust (140 ps steps)	Tdrda range		-560 to 420		ps
Output skew		50		100	ps
Output rise/fall time for DATA (20% - 80%)	TR/TF	300	350	500	ps
Output rise/fall time for DATA READY (20% - 80%)	TR/TF	300	350	500	ps
Data pipeline delay (nominal mode)	TPD	3 (port B) 3.5 (port A, 1:1 DMUX mode) 4 (port A, 1:2 DMUX mode)			Clock cycles
Data pipeline delay (nominal mode) in S/H transparent mode		2.5 (port B) 3 (port A, 1:1 DMUX mode) 3.5 (port A, 1:2 DMUX mode)			
DDRb recommended pulse width		1			ns

Figure 7-1. Differential Inputs Voltage Span (Full-scale)



The analog input full-scale range is 0.5V peak-to-peak (Vpp), or -2 dBm into the 50Ω (100Ω differential) termination resistor. In differential mode input configuration, which means 0.25V on each input, or ±125 mV around common mode voltage.

7.1 Timing Diagrams

Figure 7-2. Timing Diagram, ADC I or ADC Q, 1:2 DMUX Mode, Clock I for ADC I, Clock Q for ADC Q

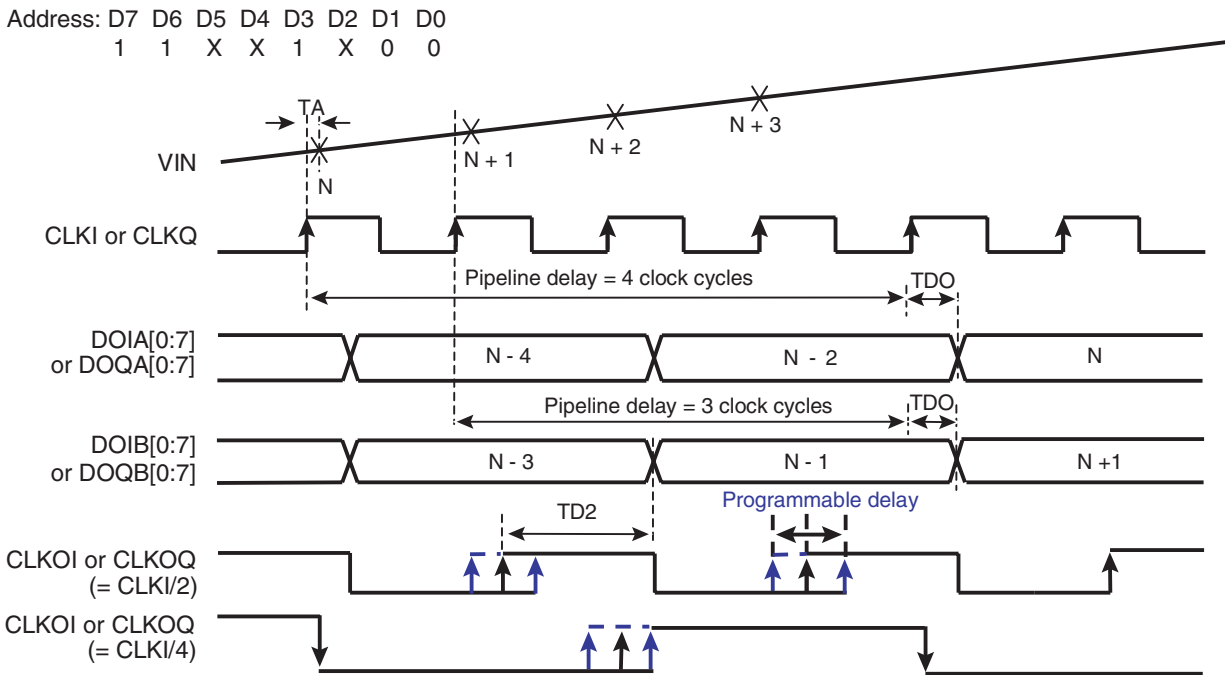
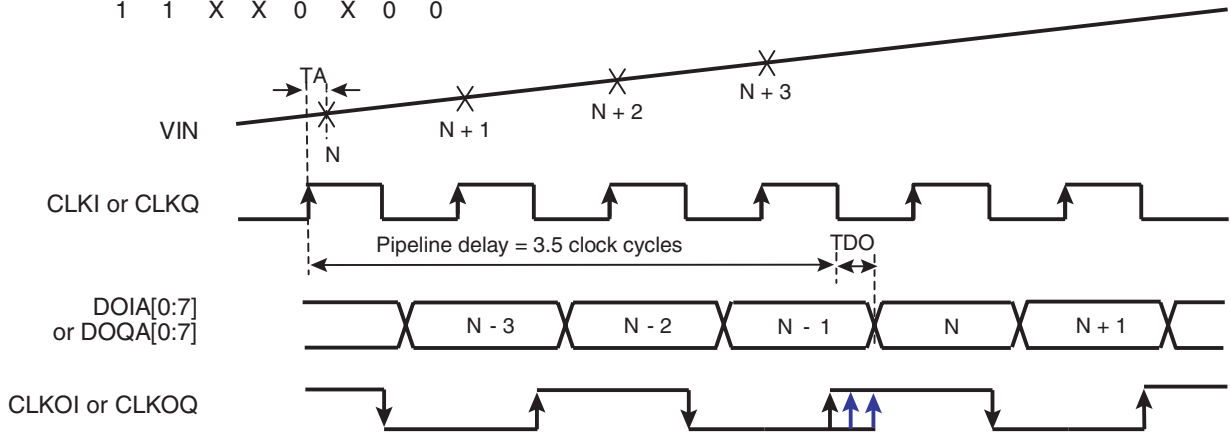


Figure 7-3. 1:1 DMUX Mode, Clock I = ADC I, Clock Q = ADC Q

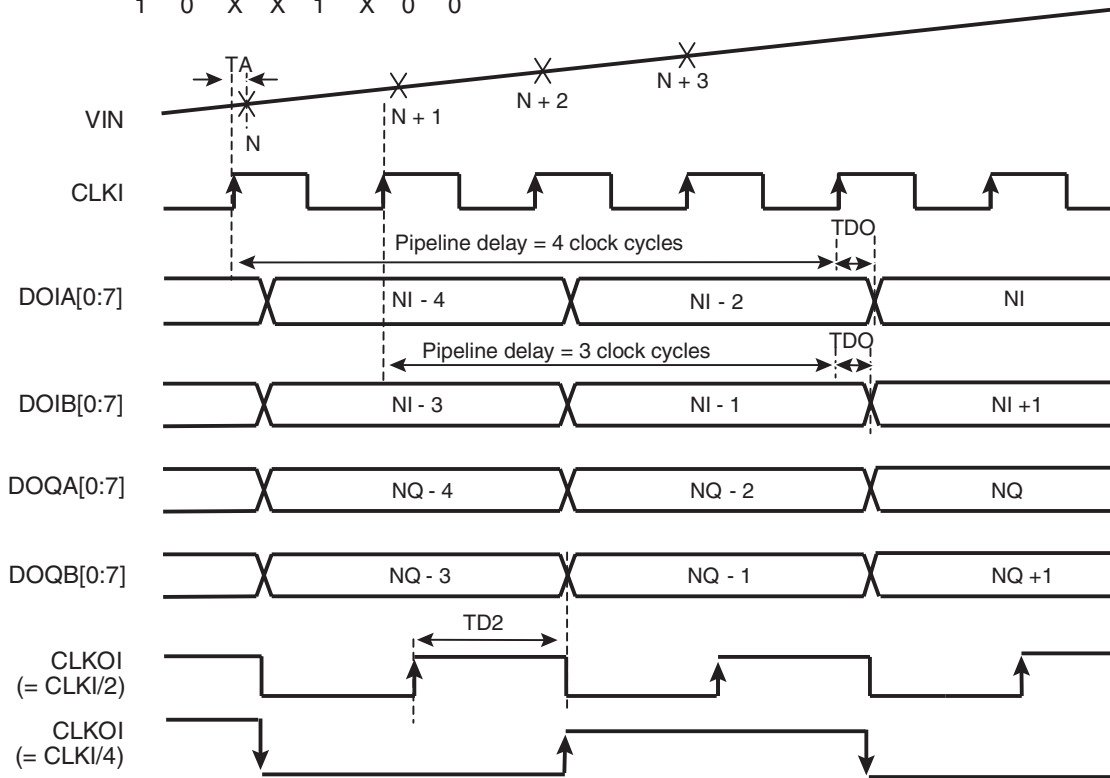
Address: D7 D6 D5 D4 D3 D2 D1 D0
 1 1 X X 0 X 0 0



$DOIB[0:7]$ and $DOQB[0:7]$ are high impedance

Figure 7-4. 1:2 DMUX Mode, Clock I = ADC I, Clock I = ADC Q

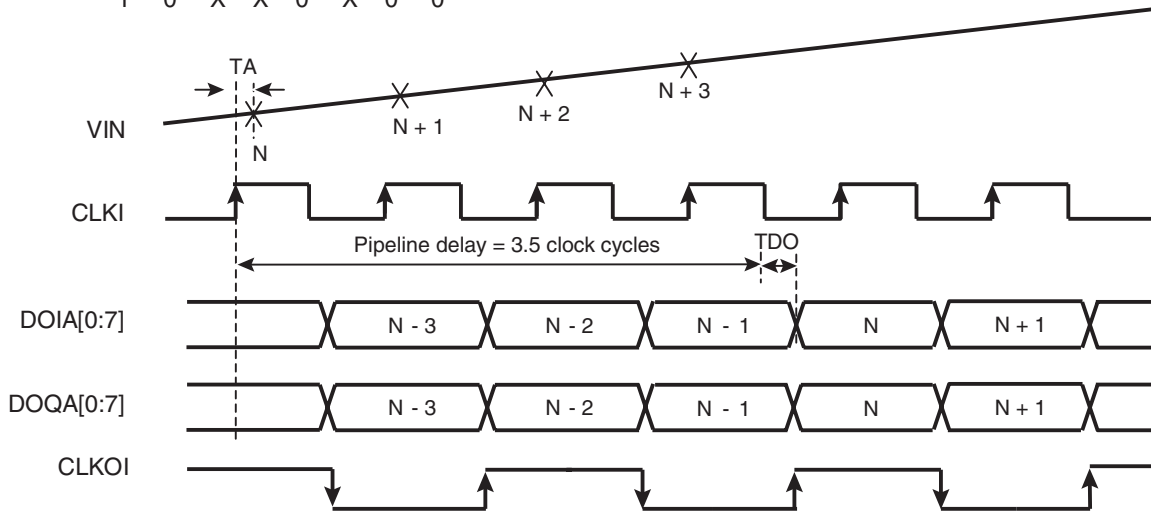
Address: D7 D6 D5 D4 D3 D2 D1 D0
 1 0 X X 1 X 0 0



$CLKOQ$ is high impedance

Figure 7-5. 1:1 DMUX Mode, Clock I = ADC I, Clock I = ADC Q

Address: D7 D6 D5 D4 D3 D2 D1 D0
 1 0 X X 0 X 0 0



DOIB[0:7] and DOQB[0:7] are high impedance
 CLKOQ is high impedance

Figure 7-6. 1:2 DMUX Mode, Clock I = ADC I, Clock IN = ADC Q

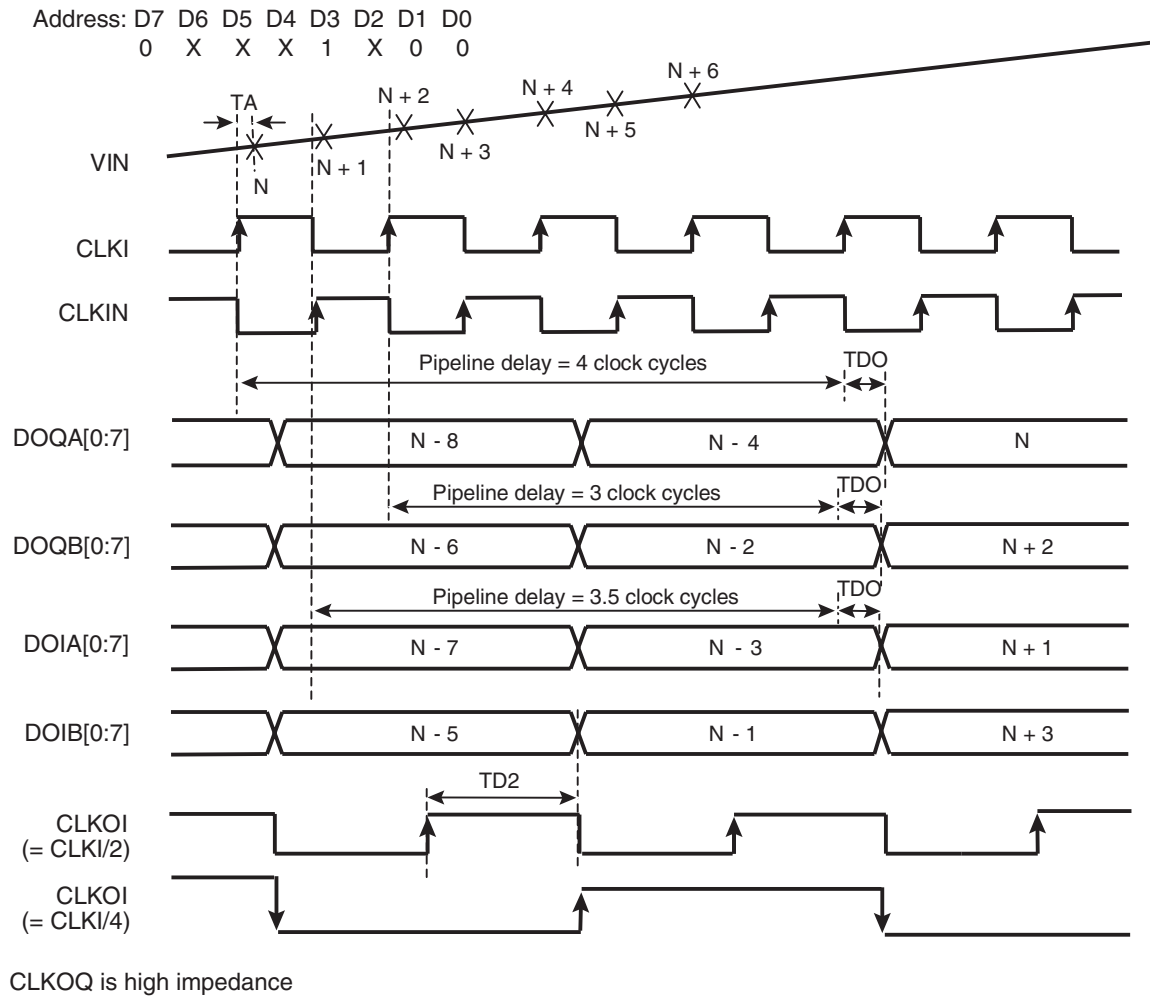
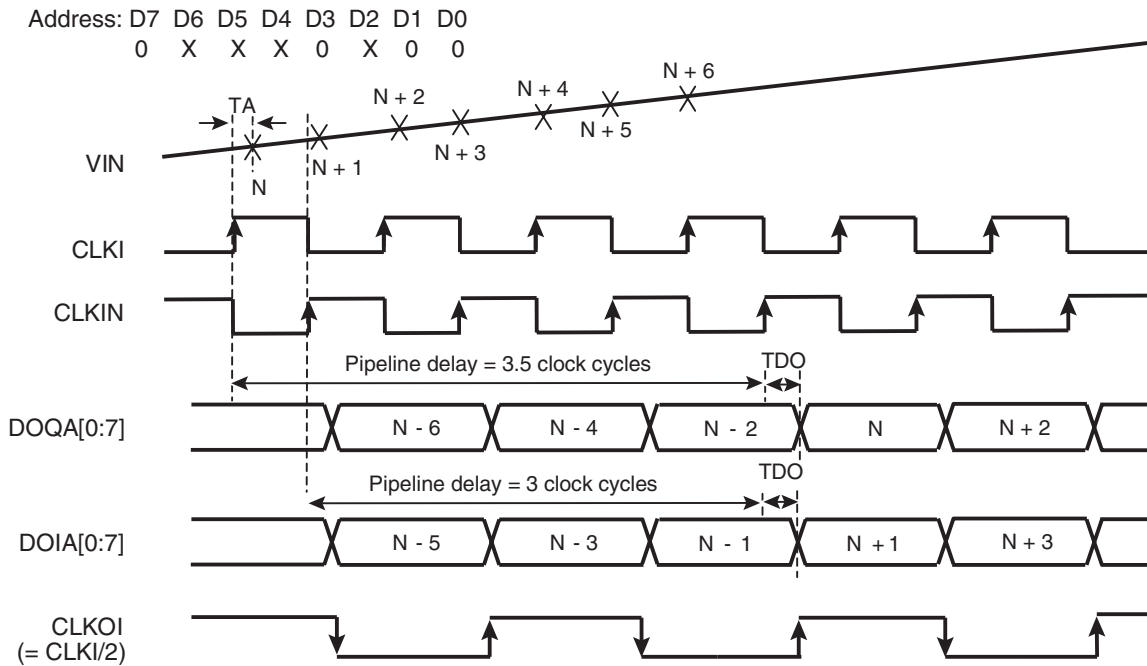
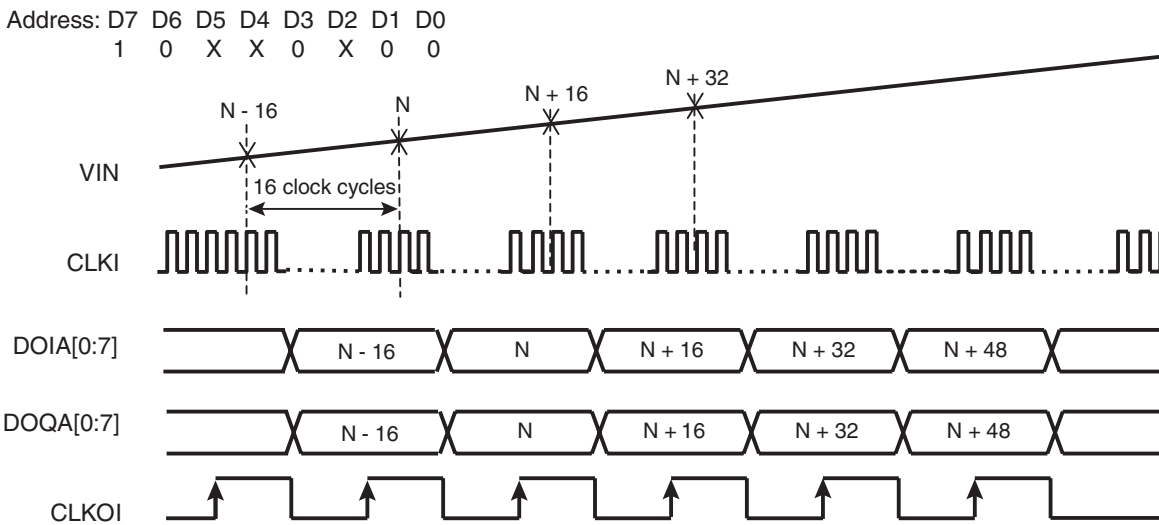


Figure 7-7. 1:1 DMUX Mode, Clock I = ADC I, Clock IN = ADC Q



DOIB[0:7] and DOQB[0:7] are high impedance
 CLKOQ is high impedance

Figure 7-8. 1:1 DMUX Mode, Decimation Mode Test (1:16 Factor)



DOIB[0:7] and DOQB[0:7] are high impedance
 CLKOQ is high impedance

Notes: 1. Frequency(CLKOI) = Frequency(Data) = Frequency(CLKI)/16.

Figure 7-9. Data Ready Reset

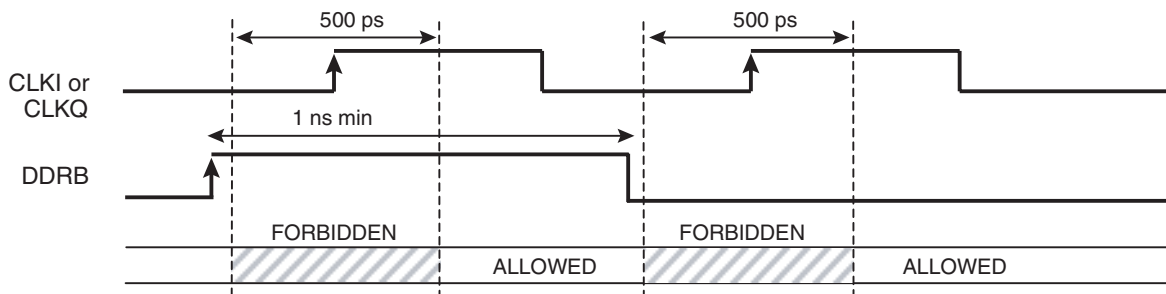
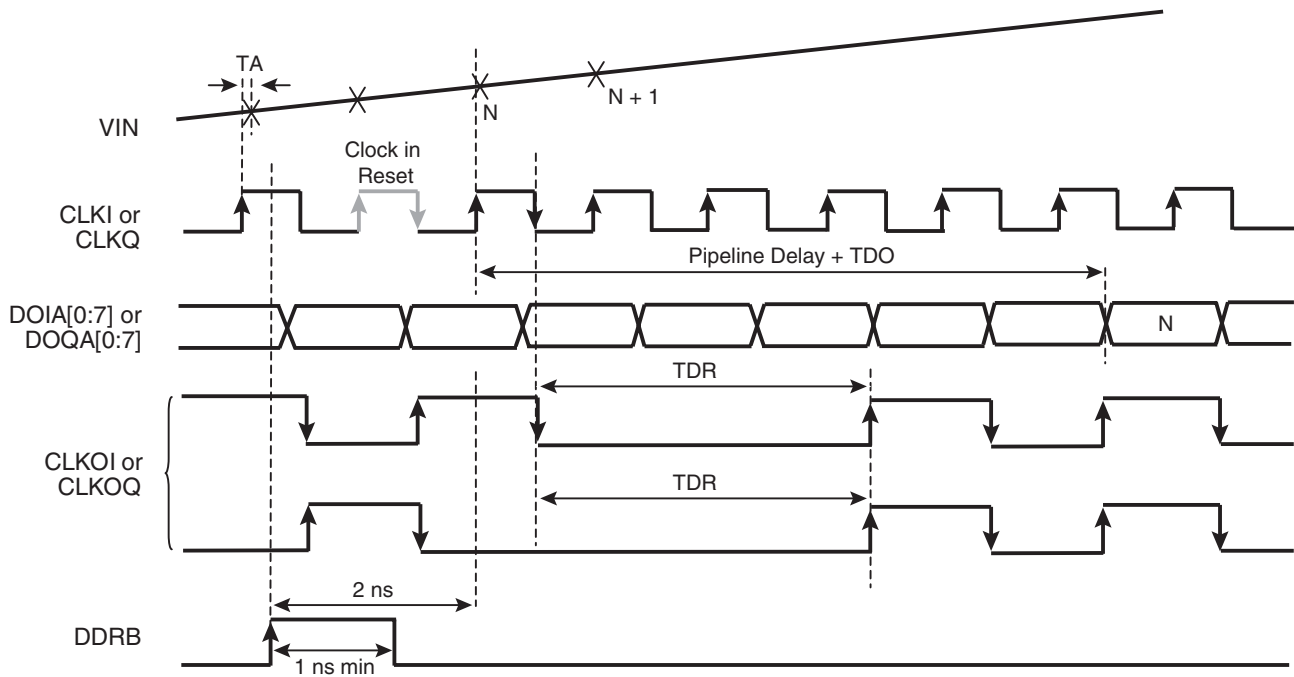
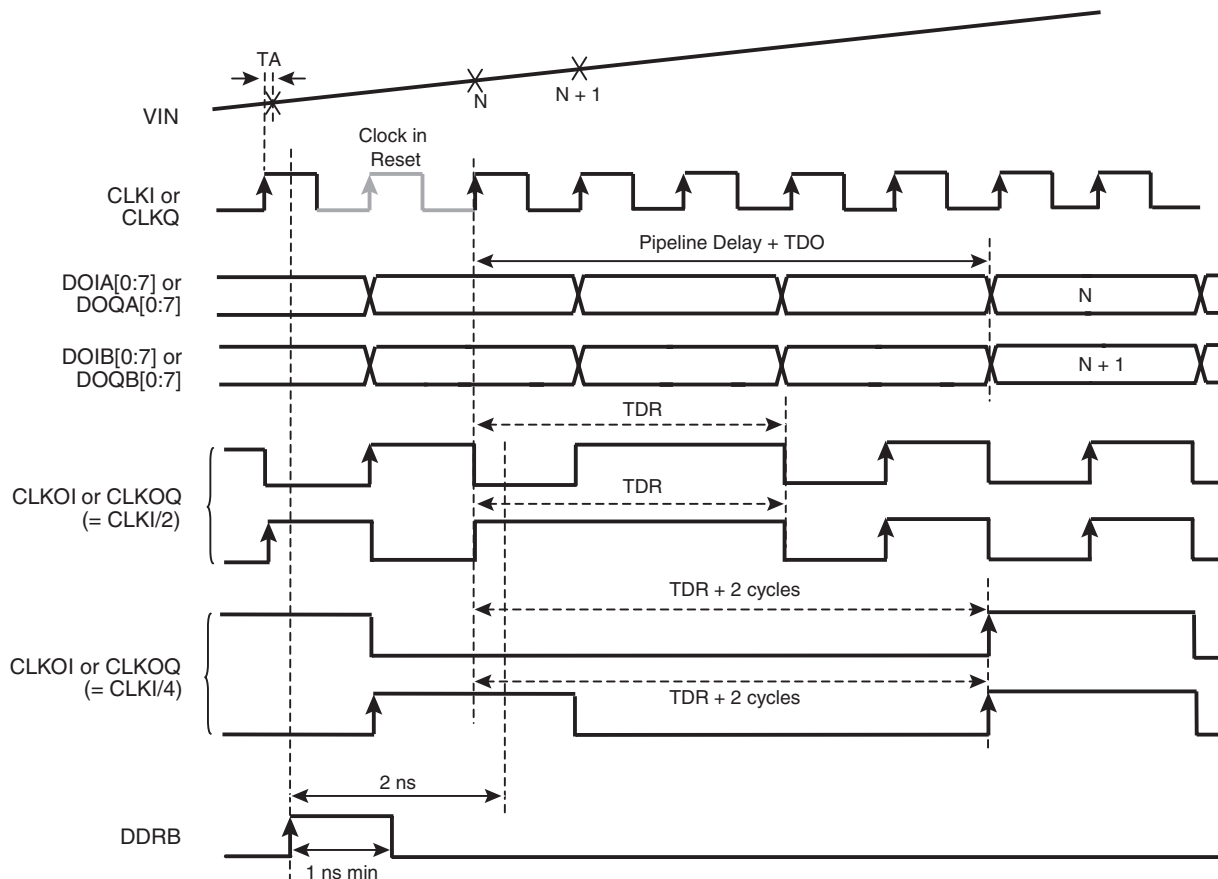


Figure 7-10. Data Ready Reset 1:1 DMUX Mode



Note: The Data Ready Reset is taken into account only 2 ns after it is asserted. The output clock first completes its cycle (if the reset occurs when it is high, it goes low only when its half cycle is complete; if the reset occurs when it is low, it remains low) and then only, remains in reset state (frozen to a low level in 1:1 DMUX mode). The next falling edge of the input clock after reset makes the output clock return to normal mode (after TDR).

Figure 7-11. Data Ready Reset 1:2 DMUX Mode

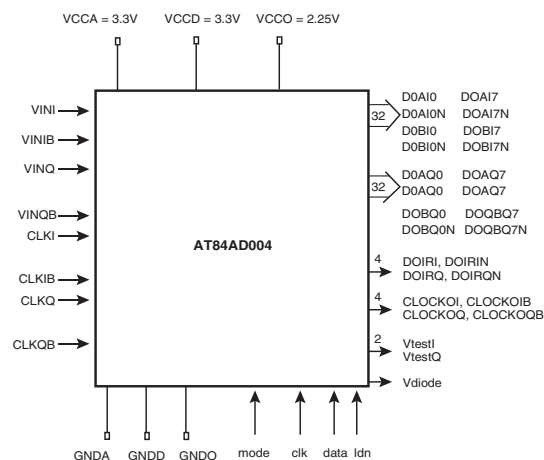


- Notes:
1. In 1:2 DMUX, Fs/2 mode:
The Data Ready Reset is taken into account only 2 ns after it is asserted. The output clock first completes its cycle (if the reset occurs when it is low, it goes high only when its half cycle is complete; if the reset occurs when it is high, it remains high) and then only, remains in reset state (frozen to a high level in 1:2 DMUX Fs/2 mode). The next rising edge of the input clock after reset makes the output clock return to normal mode (after TDR).
 2. In 1:2 DMUX, Fs/4 mode:
The Data Ready Reset is taken into account only 2 ns after it is asserted. The output clock first completes its cycle (if the reset occurs when it is high, it goes low only when its half cycle is complete; if the reset occurs when it is low, it remains low) and then only, remains in reset state (frozen to a low level in 1:2 DMUX Fs/4 mode). The next rising edge of the input clock after reset makes the output clock return to normal mode (after TDR).

7.2 Functions Description

Table 7-7. Description of Functions

Name	Function
V _{CCA}	Positive analog power supply
V _{CCD}	Positive digital power supply
V _{CCO}	Positive output power supply
GNDA	Analog ground
GNDD	Digital ground
GNDO	Output ground
V _{INI} , V _{INIB}	Differential analog inputs I
V _{INQ} , V _{INQB}	Differential analog inputs Q
CLKOI, CLKOIN, CLKOQ, CLKOQN	Differential output data ready I and Q
CLKI, CLKIN, CLKQ, CLKQN	Differential clock inputs I and Q
DDRB, DDRBN	Synchronous data ready reset I and Q
Mode	Bit selection for 3-wire bus or nominal setting
Clk	Input clock for 3-wire bus interface
Data	Input data for 3-wire bus
Ldn	Beginning and end of register line for 3-wire bus interface
<D0AI0:DOAI7> <D0AI0N:DOAI7N> <D0BI0:DOBI7> <D0BI0N:DOBI7N>	Differential output data port channel I
<D0AQ0:DOAQ7> <D0AQ0N:DOAQ7N> <D0BQ0:DOBQ7> <D0BQ0N:DOBQ7N>	Differential output data port channel Q
DOIRI, DOIRIN, DOIRQ, DOIRQN	Differential output IN range data I and Q
VtestQ	Test voltage output for ADC Q (to be left open)
VtestI	Test voltage output for ADC I (to be left open)
Cal	Output bit status internal calibration
Vdiode	Test diode voltage for T _j measurement



7.3 Digital Output Coding (Nominal Settings)

Table 7-8. Digital Output Coding (Nominal Setting)

Differential Analog Input	Voltage Level	Digital Output I or Q (Binary Coding)	Out-of-range Bit
> 250 mV	> Positive full-scale + 1/2 LSB	1 1 1 1 1 1 1 1	1
250 mV 248 mV	Positive full-scale + 1/2 LSB Positive full-scale - 1/2 LSB	1 1 1 1 1 1 1 1 1 1 1 1 1 1 1 0	0 0
1 mV -1 mV	Bipolar zero + 1/2 LSB Bipolar zero - 1/2 LSB	1 0 0 0 0 0 0 0 0 1 1 1 1 1 1 1	0 0
-248 mV -250 mV	Negative full-scale + 1/2 LSB Negative full-scale - 1/2 LSB	0 0 0 0 0 0 0 1 0 0 0 0 0 0 0 0	0 0
< -250 mV	< Negative full-scale - 1/2 LSB	0 0 0 0 0 0 0 0	1

8. Pin Description

Table 8-1. AT84AD004B Pin Description

Symbol	Pin number	Function
GNDA, GNDD, GNDO	10, 12, 22, 24, 36, 38, 40, 42, 44, 46, 51, 54, 59, 61, 63, 65, 67, 69, 85, 87, 97, 99, 109, 111, 130, 142, 144	Ground pins. To be connected to external ground plane
V _{CCA}	41, 43, 45, 60, 62, 64	Analog positive supply: 3.3V typical
V _{CCD}	9, 21, 37, 39, 66, 68, 88, 100, 112, 123, 141	3.3V digital supply
V _{CCO}	11, 23, 86, 98, 110, 143	2.25V output and 3-wire serial interface supply
V _{INI}	57, 58	In-phase (+) analog input signal of the sample & hold differential preamplifier channel I
V _{INIB}	55, 56	Inverted phase (-) of analog input signal (V _{INI})
V _{INQ}	47, 48	In-phase (+) analog input signal of the sample & hold differential preamplifier channel Q
V _{INQB}	49, 50	Inverted phase (-) of analog input signal (V _{INQ})
CLKI	124	In-phase (+) clock input signal
CLKIN	125	Inverted phase (-) clock input signal (CLKI)

Table 8-1. AT84AD004B Pin Description (Continued)

Symbol	Pin number	Function
CLKQ	129	In-phase (+) clock input signal
CLKQN	128	Inverted phase (-) clock input signal (CLKQ)
DDRB	126	Synchronous data ready reset I and Q
DDRBN	127	Inverted phase (-) of input signal (DDRB)
DOAI0, DOAI1, DOAI2, DOAI3, DOAI4, DOAI5, DOAI6, DOAI7	117, 113, 105, 101, 93, 89, 81, 77	In-phase (+) digital outputs first phase demultiplexer (channel I) DOAI0 is the LSB. DOAI7 is the MSB
DOAI0N, DOAI1N, DOAI2N, DOAI3N, DOAI4N, DOAI5N, DOAI6N, DOAI7N	118, 114, 106, 102, 94, 90, 82, 78	Inverted phase (-) digital outputs first phase demultiplexer (channel I) DOAI0N is the LSB. DOAI7N is the MSB
DOBI0, DOBI1, DOBI2, DOBI3, DOBI4, DOBI5, DOBI6, DOBI7	119, 115, 107, 103, 95, 91, 83, 79	In-phase (+) digital outputs second phase demultiplexer (channel I) DOBI0 is the LSB. DOBI7 is the MSB
DOBI0N, DOBI1N, DOBI2N, DOBI3N, DOBI4N, DOBI5N, DOBI6N, DOBI7N	120, 116, 108, 104, 96, 92, 84, 80	Inverted phase (-) digital outputs second phase demultiplexer (channel I) DOBI0N is the LSB. DOBI7N is the MSB
DOAQ0, DOAQ1, DOAQ2, DOAQ3, DOAQ4, DOAQ5, DOAQ6, DOAQ7	136, 140, 4, 8, 16, 20, 28, 32	In-phase (+) digital outputs first phase demultiplexer (channel Q) DOAI0 is the LSB. DOAQ7 is the MSB
DOAQ0N, DOAQ1N, DOAQ2N, DOAQ3N, DOAQ4N, DOAQ5N, DOAQ6N, DOAQ7N	135, 139, 3, 7, 15, 19, 27, 31	Inverted phase (-) digital outputs first phase demultiplexer (channel Q) DOAI0N is the LSB. DOAQ7N is the MSB
DOBQ0, DOBQ1, DOBQ2, DOBQ3, DOBQ4, DOBQ5, DOBQ6, DOBQ7	134, 138, 2, 6, 14, 18, 26, 30	In-phase (+) digital outputs second phase demultiplexer (channel Q) DOBQ0 is the LSB. DOBQ7 is the MSB
DOBQ0N, DOBQ1N, DOBQ2N, DOBQ3N, DOBQ4N, DOBQ5N, DOBQ6N, DOBQ7N	133, 137, 1, 5, 13, 17, 25, 29	Inverted phase (-) digital outputs second phase demultiplexer (channel Q) DOBQ0N is the LSB. DOBQ7N is the MSB
DOIRI	75	In-phase (+) out-of-range bit input (I phase) combined demultiplexer out-of-range is high on the leading edge of code 0 and code 256
DOIRIN	76	Inverted phase of output signal DOIRI
DOIRQ	34	In-phase (+) out-of-range bit input (Q phase) combined demultiplexer out-of-range is high on the leading edge of code 0 and code 256
DOIRQN	33	Inverted phase of output signal DOIRQ
MODE	74	Bit selection for 3-wire bus interface or nominal setting
CLK	73	Input clock for 3-wire bus interface
DATA	72	Input data for 3-wire bus

9. Typical Characterization Results

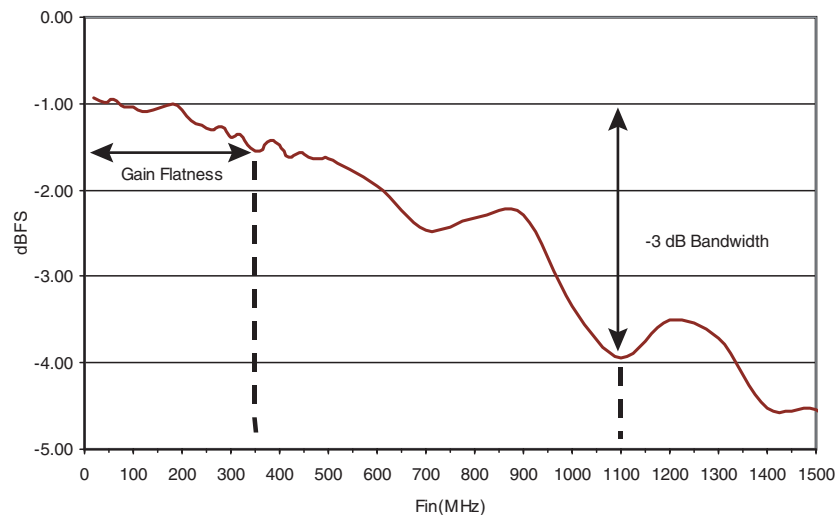
Nominal conditions (unless otherwise specified):

- $V_{CCA} = 3.3V$; $V_{CCD} = 3.3V$; $V_{CCO} = 2.25V$
- $V_{INI} - V_{INB}$ or V_{INQ} to $V_{INQB} = 500$ mVpp full-scale differential input
- LVDS digital outputs (100Ω)
- T_{amb} (typical) = $25^{\circ}C$
- Full temperature range: $0^{\circ}C < T_{amb} < 70^{\circ}C$ (commercial grade)
or $-40^{\circ}C < T_{amb} < 85^{\circ}C$ (industrial grade)

9.1 Typical Full Power Input Bandwidth

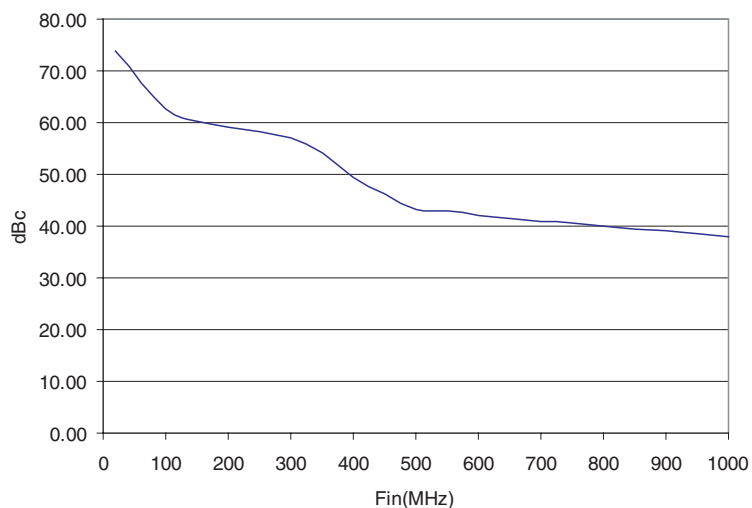
- $F_s = 500$ Msps
- $P_{clock} = 0$ dBm
- $P_{in} = -1$ dBFS
- Gain flatness (± 0.5 dB) from DC to > 350 MHz
- Full power input bandwidth at -3 dB > 1 GHz

Figure 9-1. Full Power Input Bandwidth



9.2 Typical Crosstalk

Figure 9-2. Crosstalk ($F_s = 500$ Msp/s)



Note: Measured on the AT84AD004BTD-EB Evaluation Board.

9.3 Typical DC, INL and DNL Patterns

1:2 DMUX mode, $F_s/4$ DR type

Figure 9-3. Typical INL ($F_s = 50$ Msp/s, $F_{in} = 1$ MHz, Saturated Input)

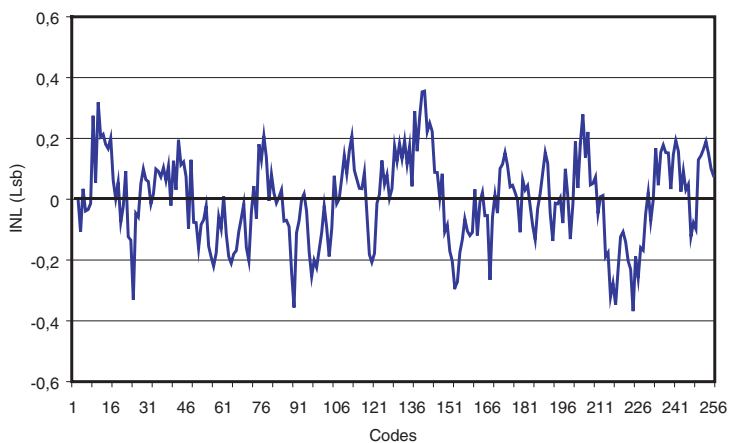
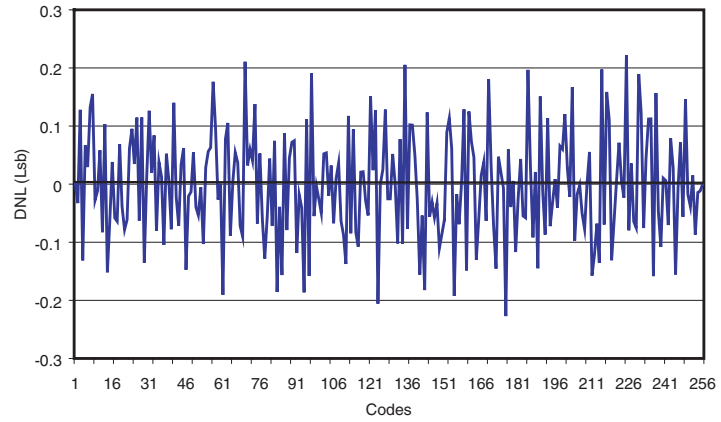


Figure 9-4. Typical DNL ($F_s = 50$ Mps, $F_{in} = 1$ MHz, Saturated Input)

9.4 Typical Dynamic Performances Versus Sampling Frequency

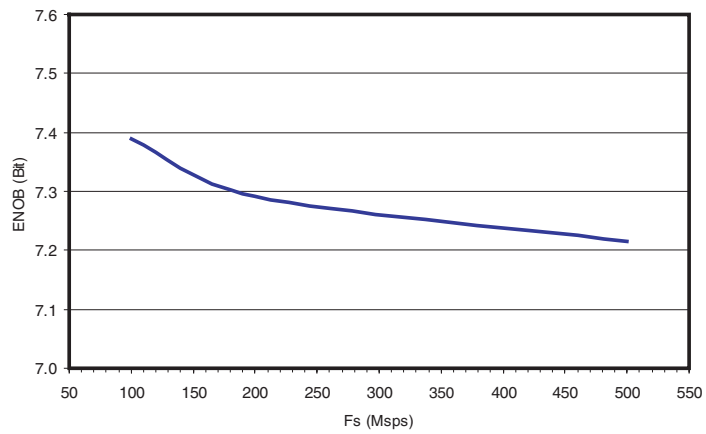
Figure 9-5. ENOB Versus Sampling Frequency in Nyquist Conditions ($F_{in} = F_s/2$)

Figure 9-6. SFDR Versus Sampling Frequency in Nyquist Conditions ($F_{in} = F_s/2$)

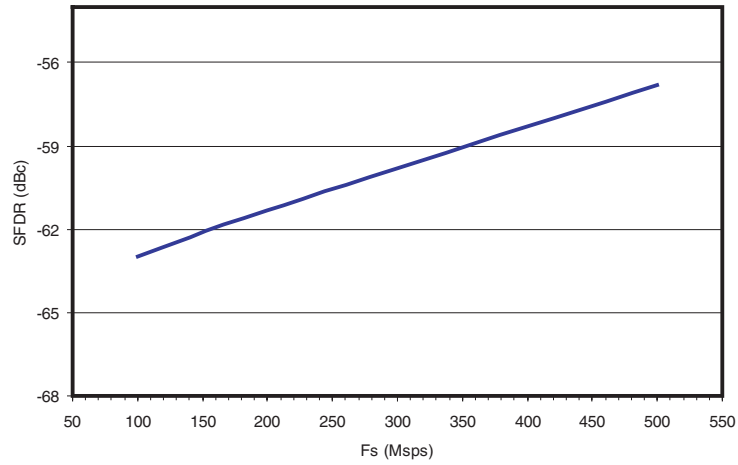


Figure 9-7. THD Versus Sampling Frequency in Nyquist Conditions ($F_{in} = F_s/2$)

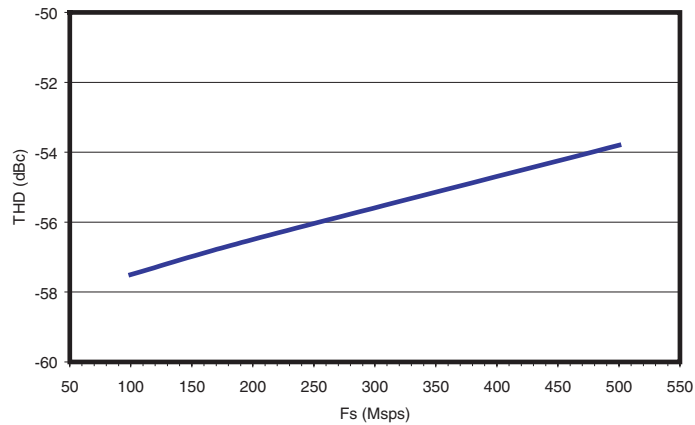
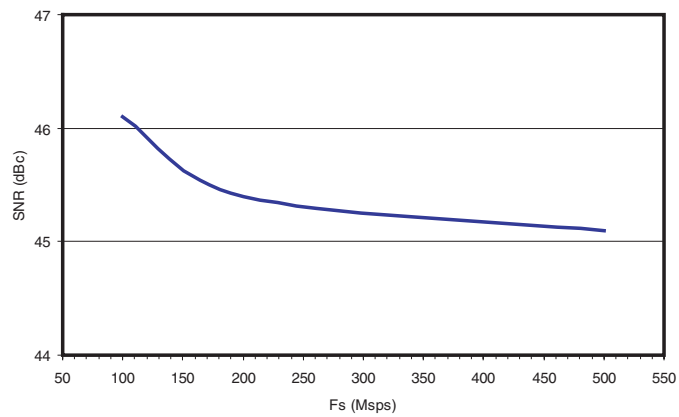


Figure 9-8. SNR Versus Sampling Frequency in Nyquist Conditions ($F_{in} = F_s/2$)



9.5 Typical Dynamic Performances Versus Input Frequency

Figure 9-9. ENOB Versus Input Frequency ($F_s = 500$ Msp/s)

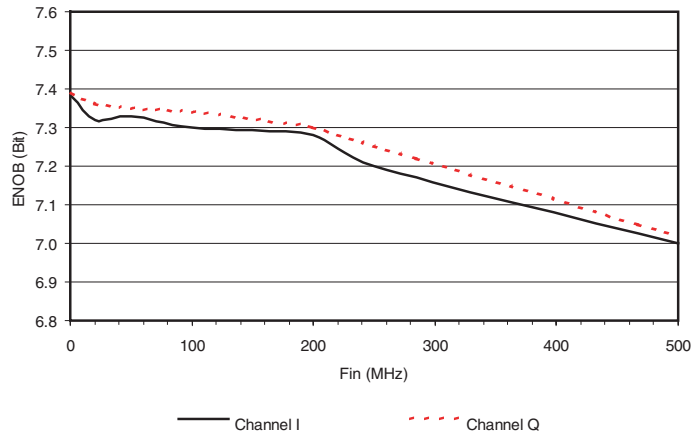


Figure 9-10. SFDR Versus Input Frequency ($F_s = 500$ Msp/s)

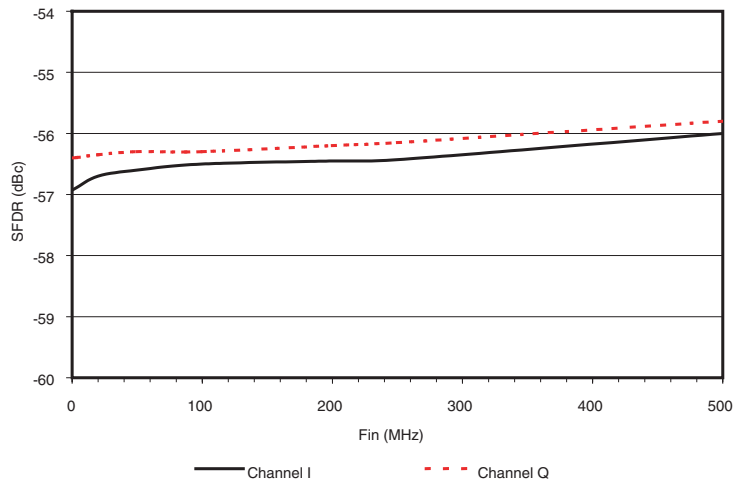


Figure 9-11. THD Versus Input Frequency (Fs = 500 Msps)

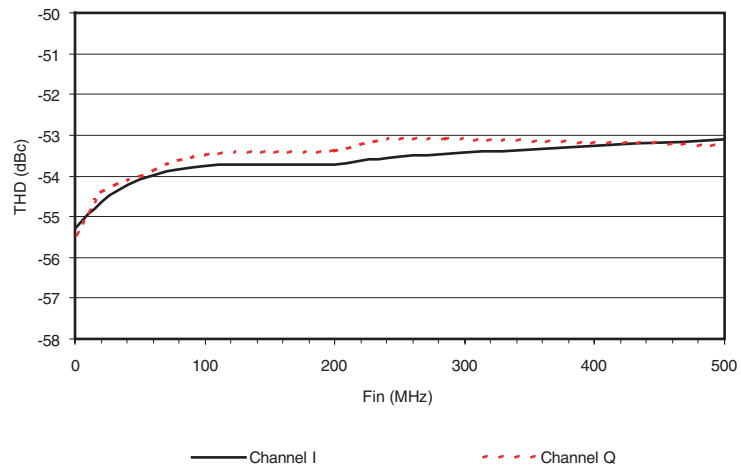
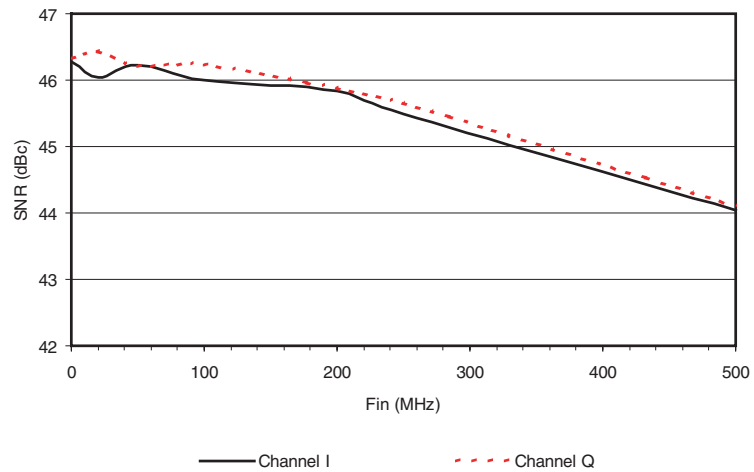


Figure 9-12. SNR Versus Input Frequency (Fs = 500 Msps)



9.6 Typical Signal Spectrum

Figure 9-13. $F_s = 500$ Msp/s and $F_{in} = 20$ MHz (1:2 DMUX, $F_s/4$ DR Type
 $F_iSDA = -35$ ps, $ISA = 0$ ps)

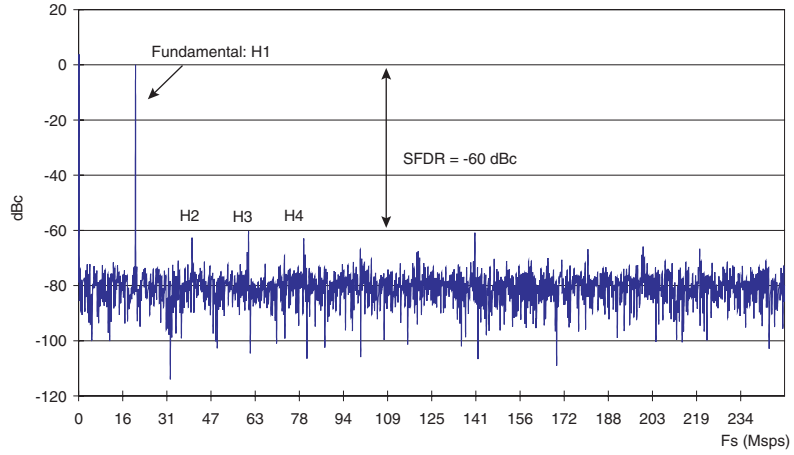


Figure 9-14. $F_s = 500$ Msp/s and $F_{in} = 250$ MHz (1:2 DMUX, $F_s/4$ DR Type
 $F_iSDA = -35$ ps, $ISA = 0$ ps)

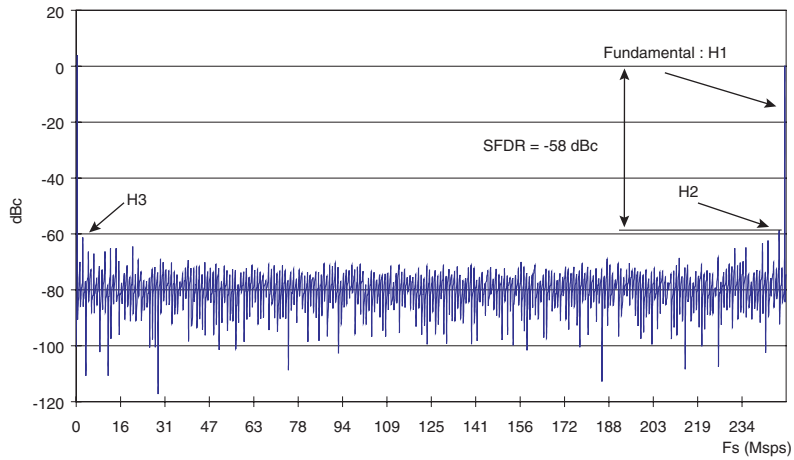
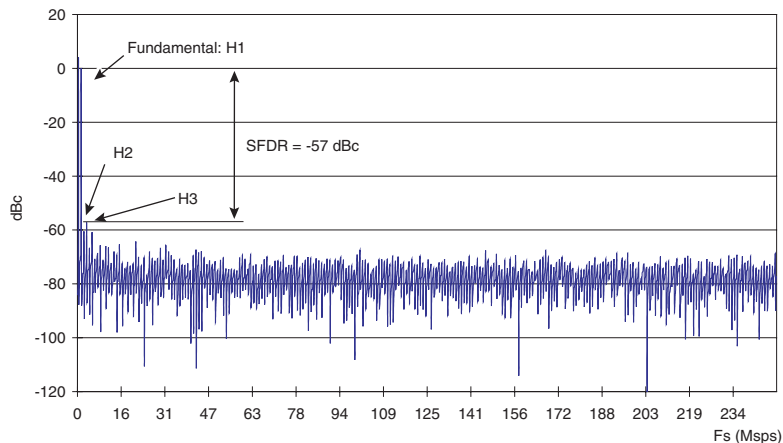
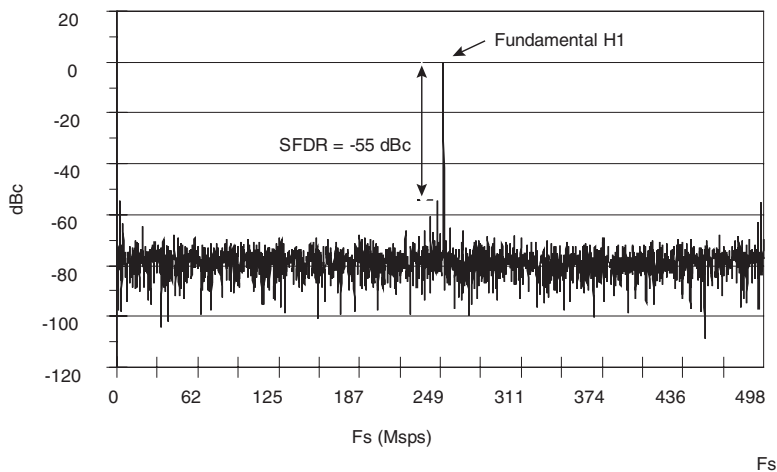


Figure 9-15. $F_s = 500$ Msp and $F_{in} = 500$ MHz (1:2 DMUX, $F_s/4$ DR Type
 $F_iSDA = -35$ ps, $ISA = 0$ ps)



Note: The spectra are given with respect to the output clock frequency observed by the acquisition system (Figures 27 to 29).

Figure 9-16. $F_s = 500$ Msp and $F_{in} = 250$ MHz (Interleaving Mode $F_{int} = 1$ Gsp
 1:1 DMUX, $F_iSDA = -35$ ps, $ISA = 0$ ps)



9.7 Typical Performance Sensitivity Versus Power Supplies and Temperature

Figure 9-17. ENOB Versus V_{CCA} ($F_s = 500$ Msps, $F_{in} = 250$ MHz, 1:2 DMUX, $F_s/4$ DR Type, $ISA = 0$ ps)

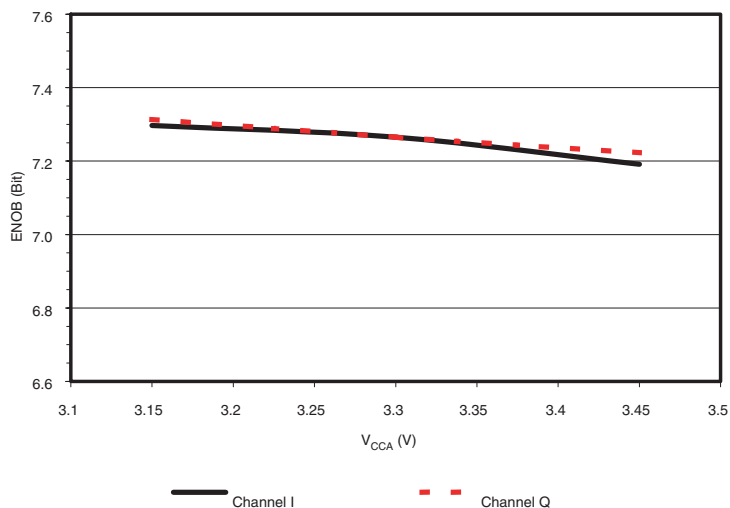


Figure 9-18. SFDR Versus V_{CCA} ($F_s = 500$ Msps, $F_{in} = 250$ MHz, 1:2 DMUX, $F_s/4$ DR Type, $ISA = 0$ ps)

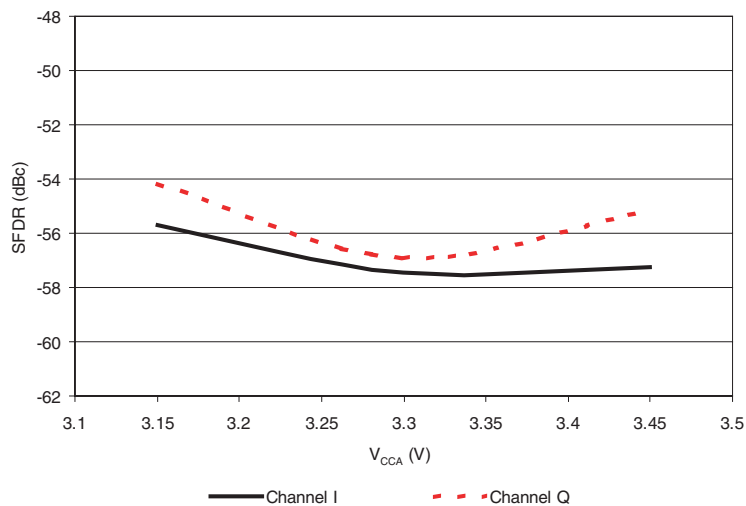


Figure 9-19. THD Versus V_{CCA} ($F_s = 500$ Mps, $F_{in} = 250$ MHz, 1:2 DMUX, $F_s/4$ DR Type, $ISA = 0$ ps)

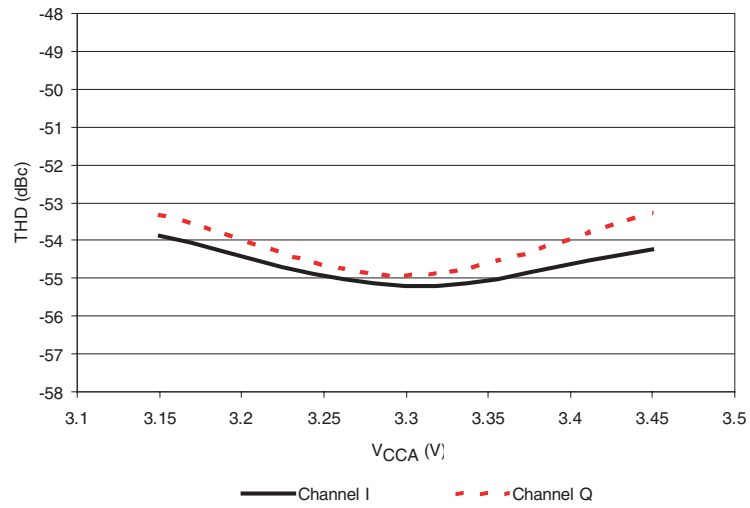


Figure 9-20. SNR Versus V_{CCA} ($F_s = 500$ Mps, $F_{in} = 250$ MHz, 1:2 DMUX, $F_s/4$ DR Type, $ISA = 0$ ps)

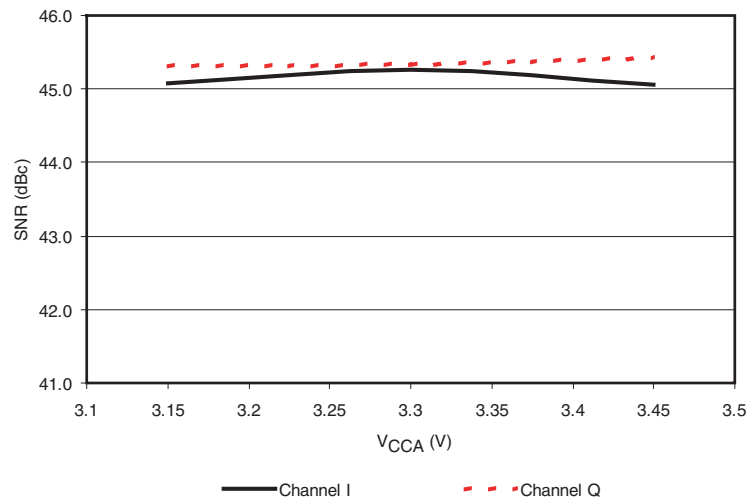


Figure 9-21. ENOB Versus Ambient Temperature ($F_s = 500$ Msps, $F_{in} = 250$ MHz, 1:2 DMUX, $F_s/4$ DR Type)

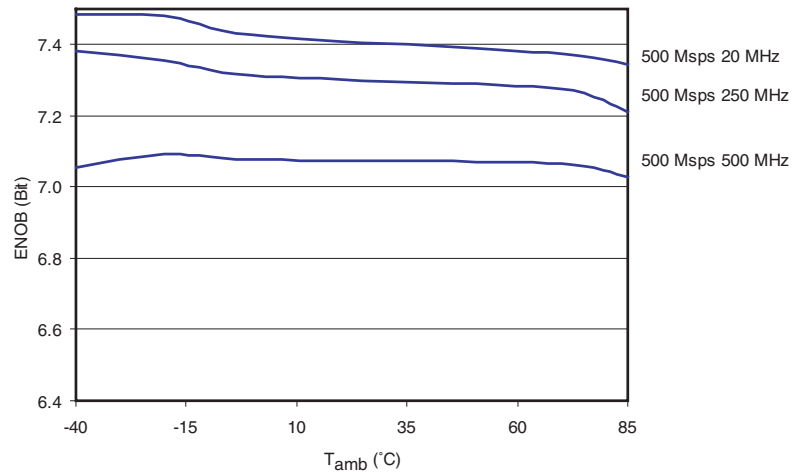


Figure 9-22. SFDR Versus Ambient Temperature ($F_s = 500$ Msps, $F_{in} = 250$ MHz, 1:2 DMUX, $F_s/4$ DR Type)

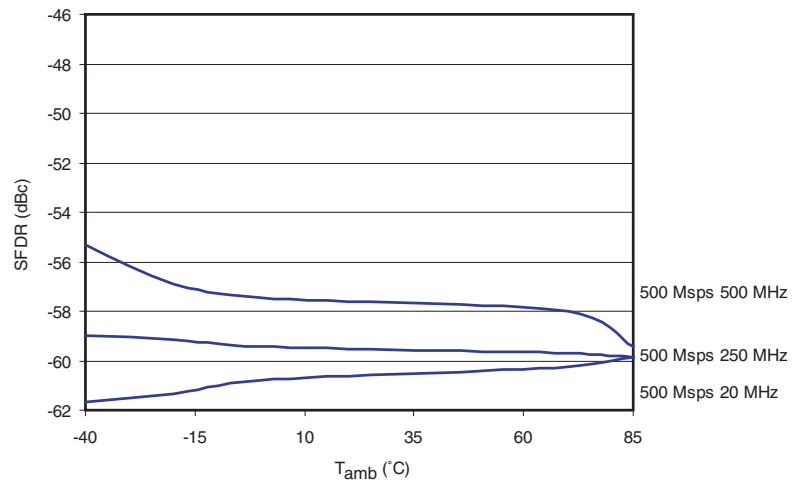


Figure 9-23. THD Versus Ambient Temperature (Fs = 500 Msps, Fin = 250 MHz, 1:2 DMUX, Fs/4 DR Type)

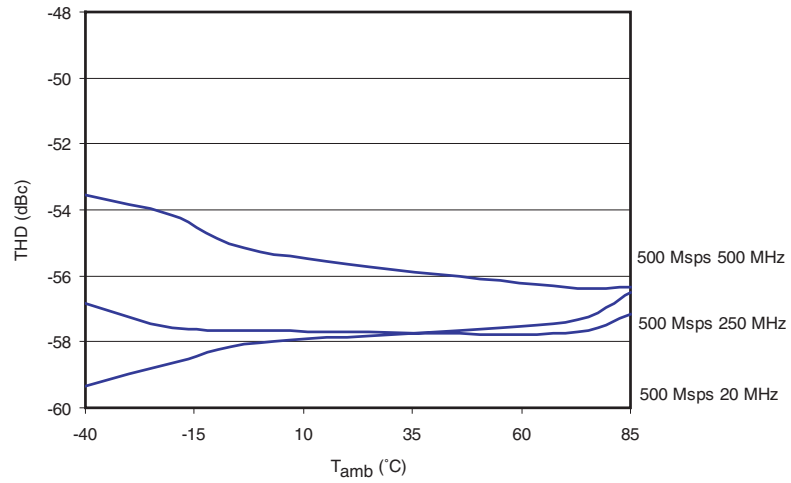
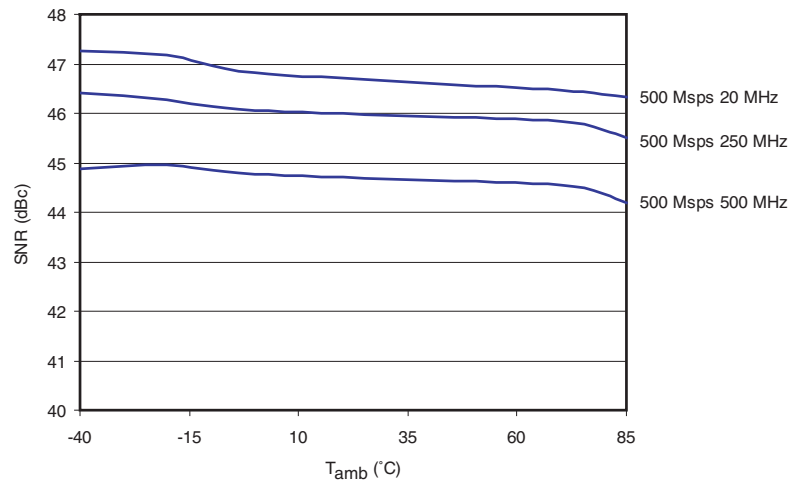


Figure 9-24. SNR Versus Ambient Temperature (Fs = 500 Msps, Fin = 250 MHz, 1:2 DMUX, Fs/4 DR Type)



10. Test and Control Features

10.1 3-wire Serial Interface Control Setting

Table 10-1. 3-wire Serial Interface Control Settings

Mode	Characteristics
Mode = 1 (2.25V)	3-wire serial bus interface activated
Mode = 0 (0V)	3-wire serial bus interface deactivated Nominal setting: Dual channel I and Q activated One clock I 0 dB gain DMUX mode 1:1 DRDA I & Q = 0 ps ISA I & Q = 0 ps FiSDA Q = 0 ps Binary output Decimation test mode OFF Calibration setting OFF Data Ready = $F_s / 2$

10.1.1 3-wire Serial Interface and Data Description

The 3-wire bus is activated with the control bit mode set to 1. The length of the word is 19 bits: 16 for the data and 3 for the address. The maximum clock frequency is 50 MHz.

Table 10-2. 3-wire Serial Interface Address Setting Description

Address	Setting
000	Standby Gray/binary mode 1:1 or 1:2 DMUX mode Analog input MUX Clock selection Auto-calibration Decimation test mode Data Ready Delay Adjust
001	Analog gain adjustment Data7 to Data0: gain channel I Data15 to Data8: gain channel Q Code 00000000: -1.5 dB Code 10000000: 0 dB Code 11111111: 1.5 dB Steps: 0.011 dB
010	Offset compensation Data7 to Data0: offset channel I Data15 to Data8: offset channel Q Data7 and Data15: sign bits Code 11111111b: 31.75 LSB Code 10000000b: 0 LSB Code 00000000b: 0 LSB Code 01111111b: -31.75 LSB Steps: 0.25 LSB Maximum correction: ± 31.75 LSB
011	Gain compensation Data6 to Data0: channel I/Q (Q is matched to I) Code 11111111b: -0.315 dB Code 10000000b: 0 dB Code 00000000b: 0 dB Code 01111111b: 0.315 dB Steps: 0.005 dB Data6: sign bit
100	Internal Settling Adjustment (ISA) Data2 to Data0: channel I Data5 to Data3: channel Q Data15 to Data6: 1000010000

Table 10-3. 3-wire Serial Interface Data Setting Description

Setting for Address: 000	D15	D14	D13	D12	D11	D10	D9 ⁽¹⁾	D8	D7	D6	D5	D4	D3	D2	D1	D0
Full standby mode	X	X	X	X	X	X	0	X	X	X	X	X	X	X	1	1
Standby channel I ⁽²⁾	X	X	X	X	X	X	0	X	X	X	X	X	X	X	0	1
Standby channel Q ⁽³⁾	X	X	X	X	X	X	0	X	X	X	X	X	X	X	1	0
No standby mode	X	X	X	X	X	X	0	X	X	X	X	X	X	X	0	0
Binary output mode	X	X	X	X	X	X	0	X	X	X	X	X	X	1	X	X
Gray output mode	X	X	X	X	X	X	0	X	X	X	X	X	X	0	X	X
DMUX 1:2 mode	X	X	X	X	X	X	0	X	X	X	X	X	1	X	X	X
DMUX 1:1 mode	X	X	X	X	X	X	0	X	X	X	X	X	0	X	X	X
Analog selection mode Input I → ADC I Input Q → ADC Q	X	X	X	X	X	X	0	X	X	X	1	1	X	X	X	X
Analog selection mode Input I → ADC I Input I → ADC Q	X	X	X	X	X	X	0	X	X	X	1	0	X	X	X	X
Analog selection mode Input Q → ADC I Input Q → ADC Q	X	X	X	X	X	X	0	X	X	X	0	X	X	X	X	X
Clock Selection mode CLKI → ADC I CLKQ → ADC Q	X	X	X	X	X	X	0	X	1	1	X	X	X	X	X	X
Clock selection mode CLKI → ADC I CLKI → ADC Q	X	X	X	X	X	X	0	X	1	0	X	X	X	X	X	X
Clock selection mode CLKI → ADC I CLKIN → ADC Q	X	X	X	X	X	X	0	X	0	X	X	X	X	X	X	X
Decimation OFF mode	X	X	X	X	X	X	0	0	X	X	X	X	X	X	X	X
Decimation ON mode	X	X	X	X	X	X	0	1	X	X	X	X	X	X	X	X
Keep last calibration calculated value ⁽⁴⁾ No calibration phase	X	X	X	X	0	1	0	X	X	X	X	X	X	X	X	X
No calibration phase ⁽⁵⁾ No calibration value	X	X	X	X	0	0	0	X	X	X	X	X	X	X	X	X
Start a new calibration phase	X	X	X	X	1	1	0	X	X	X	X	X	X	X	X	X

Table 10-3. 3-wire Serial Interface Data Setting Description (Continued)

Setting for Address: 000	D15	D14	D13	D12	D11	D10	D9 ⁽¹⁾	D8	D7	D6	D5	D4	D3	D2	D1	D0
Control wait bit calibration ⁽⁶⁾	X	X	a	b	X	X	0	X	X	X	X	X	X	X	X	X
In 1:2 DMUX FDataReady I & Q = Fs/2	X	0	X	X	X	X	0	X	X	X	X	X	X	X	X	X
In 1:2 DMUX FDataReady I & Q = Fs/4	X	1	X	X	X	X	0	X	X	X	X	X	X	X	X	X

- Notes:
- D9 must be set to "0"
 - Mode standby channel I: use analog input I Vini, Vinib and Clocki.
 - Mode standby channel Q: use analog input Q Vinq, Vinqb and Clockq.
 - Keep last calibration calculated value - no calibration phase: D11 = 0 and D10 = 1. No new calibration is required. The values taken into account for the gain and offset are either from the last calibration phase or are default values (reset values).
 - No calibration phase - no calibration value: D11 = 0 and D10 = 0. No new calibration phase is required. The gain and offset compensation functions can be accessed externally by writing in the registers at address 010 for the offset compensation and at address 011 for the gain compensation.
 - The control wait bit gives the possibility to change the internal setting for the auto-calibration phase:
For high clock rates (= 500 Msps) use a = b = 1.
For clock rates > 250 Msps and < 500 Msps use a = 1 and b = 0.
For clock rates > 125 Msps and < 250 Msps use a = 0 and b = 1.
For low clock rates < 125 Msps use a = 0 and b = 0.

10.1.2 3-wire Serial Interface Timing Description

The 3-wire serial interface is a synchronous write-only serial interface made of three wires:

- sclk: serial clock input
- sldn: serial load enable input
- sdata: serial data input

The 3-wire serial interface gives write-only access to as many as 8 different internal registers of up to 16 bits each. The input format is always fixed with 3 bits of register address followed by 16 bits of data. The data and address are entered with the Most Significant Bit (MSB) first.

The write procedure is fully synchronous with the rising clock edge of "sclk" and described in the write chronogram (Figure 10-1 on page 40).

- "sldn" and "sdata" are sampled on each rising clock edge of "sclk" (clock cycle).
- "sldn" must be set to 1 when no write procedure is performed.
- A minimum of one rising clock edge (clock cycle) with "sldn" at 1 is required for a correct start of the write procedure.
- A write starts on the first clock cycle with "sldn" at 0. "sldn" must stay at 0 during the complete write procedure.
- During the first 3 clock cycles with "sldn" at 0, 3 bits of the register address from MSB (a[2]) to LSB (a[0]) are entered.
- During the next 16 clock cycles with "sldn" at 0, 16 bits of data from MSB (d[15]) to LSB (d[0]) are entered.

- An additional clock cycle with “sldn” at 0 is required for parallel transfer of the serial data d[15:0] into the addressed register with address a[2:0]. This yields 20 clock cycles with “sldn” at 0 for a normal write procedure.
- A minimum of one clock cycle with “sldn” returned at 1 is requested to close the write procedure and make the interface ready for a new write procedure. Any clock cycle where “sldn” is at 1 *before* the write procedure is completed interrupts this procedure and no further data transfer to the internal registers is performed.
- Additional clock cycles with “sldn” at 0 *after* the parallel data transfer to the register (done at the 20th consecutive clock cycle with “sldn” at 0) do not affect the write procedure and are ignored.

It is possible to have only one clock cycle with “sldn” at 1 between two following write procedures.

- 16 bits of data must always be entered even if the internal addressed register has less than 16 bits. Unused bits (usually MSBs) are ignored. Bit signification and bit positions for the internal registers are detailed in [Table 10-2 on page 36](#).

To reset the registers, the Pin mode can be used as a reset pin for chip initialization, even when the 3-wire serial interface is used.

Figure 10-1. Write Chronogram

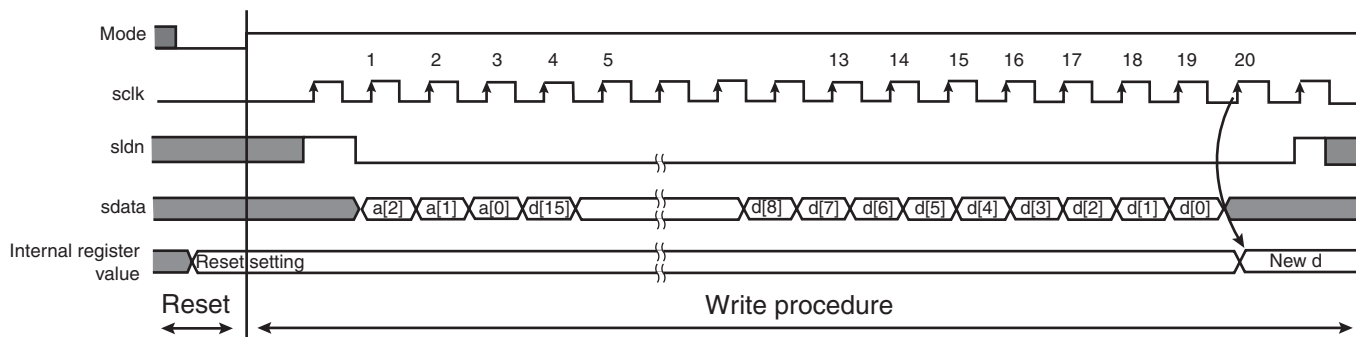


Figure 10-2. Timing Definition

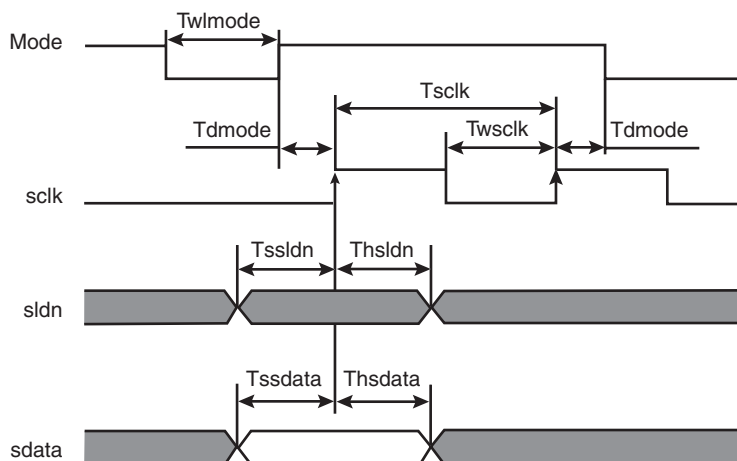


Table 10-4. Timing Description

Name	Parameter	Value			Unit
		Min	Typ	Max	
Tsclk	Sclk period	20			ns
Twsclk	High or low time of sclk	5			ns
Tssldn	Setup time of sldn before rising edge of sclk	4			ns
Thsldn	Hold time of sldn after rising edge of sclk	2			ns
Tssdata	Setup time of sdata before rising edge of sclk	4			ns
Thsdata	Hold time of sdata after rising edge of sclk	2			ns
Twlmode	Minimum low pulse width of mode	5			ns
Tdmode	Minimum delay between an edge of mode and the rising edge of sclk	10			ns

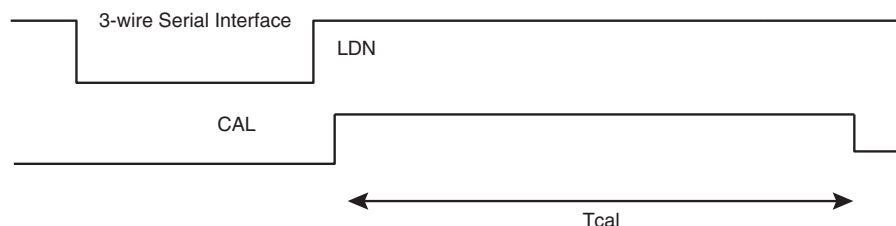
10.1.3 Calibration Description

The AT84AD004B offers the possibility of reducing offset and gain matching between the two ADC cores. An internal digital calibration may start right after the 3-wire serial interface has been loaded (using data D12 of the 3-wire serial interface with address 000).

The beginning of calibration disables the two ADCs and a standard data acquisition is performed. The output bit CAL goes to a high level during the entire calibration phase. When this bit returns to a low level, the two ADCs are calibrated with offset and gain and can be used again for a standard data acquisition.

If only one channel is selected (I or Q) the offset calibration duration is divided by two and no gain calibration between the two channels is necessary.

Figure 10-3. Internal Timing Calibration



The Tcal duration is a multiple of the clock frequency ClockI (master clock). Even if a dual clock scheme is used during calibration, ClockQ will not be used.

The control wait bits (D13 and D14) give the possibility of changing the calibration's setting depending on the clock's frequency:

- For high clock rates ($= 500$ Msps) use $a = b = 1$, $T_{cal} = 10112$ clock I periods.
- For clock rates > 250 Msps and < 500 Msps use $a = 1$, $b = 0$, $T_{cal} = 6016$ clock I periods.
- For clock rates > 125 Msps and < 250 Msps use $a = 0$, $b = 1$, $T_{cal} = 3968$ clock I periods.
- For low clock rates (< 125 Msps) use $a = 0$, $b = 0$, $T_{cal} = 2944$ clock I periods.

The calibration phase is necessary when using the AT84AD004B in interleaved mode, where one analog input is sampled at both ADC cores on the common input clock's rising and falling edges. This operation is equivalent to converting the analog signal at twice the clock frequency

Table 10-5. Matching Between Channels

Parameter	Value			Unit
	Min	Typ	Max	
Gain error (single channel I or Q) without calibration		0		%
Gain error (single channel I or Q) with calibration	-2	0	2	%
Offset error (single channel I or Q) without calibration		0		LSB
Offset error (single channel I or Q) with calibration	-2	0	2	LSB
Mean offset code without calibration (single channel I or Q)		127.5		
Mean offset code with calibration (single channel I or Q)	126	127.5	129	

During the ADC's auto-calibration phase, the dual ADC is set with the following:

- Decimation mode ON
- 1:1 DMUX mode
- Binary mode

Any external action applied to any signal of the ADC's registers is inhibited during the calibration phase.

10.1.4 Gain and Offset Compensation Functions

It is also possible for the user to have external access to the ADC's gain and offset compensation functions:

- Offset compensation between I and Q channels (at address 010)
- Gain compensation between I and Q channels (at address 011)

To obtain manual access to these two functions, which are used to set the offset to middle code 127.5 and to match the gain of channel Q with that of channel I (if only one channel is used, the gain compensation does not apply), it is necessary to set the ADC to "manual" mode by writing 0 at bits D11 and D10 of address 000.

10.1.5 Built-in Test (BIT)

A Built-in Test (BIT) function is available to allow rapid testing of the device's I/O by either applying a defined static pattern to the ADC or by generating a dynamic ramp at the ADC's output. This function is controlled via the 3-wire bus interface at address 101.

- The BIT is active when Data0 = 1 at address 110.
- The BIT is inactive when Data0 = 0 at address 110.
- The Data1 bit allows choosing between static mode (Data1 = 0) and dynamic mode (Data1 = 1).

When the static BIT is selected (Data1 = 0), it is possible to write any 8-bit pattern by defining the Data9 to Data2 bits. Port B then outputs an 8-bit pattern equal to *Data9 ... Data2*, and Port A outputs an 8-bit pattern equal to *NOT (Data9 ... Data2)*.

Example:

Address = 110

Data =

D15	D14	D13	D12	D11	D10	D9	D8	D7	D6	D5	D4	D3	D2	D1	D0
X	X	X	X	X	X	0	1	0	1	0	1	0	1	0	1

One should then obtain 01010101 on Port B and 10101010 on Port A.

When the dynamic mode is chosen (Data1 = 1) port B outputs a rising ramp while Port A outputs a decreasing one.

Note: In dynamic mode, use the DRDA function to align the edges of CLK0 with the middle of the data.

10.1.6 Decimation Mode

The decimation mode is provided to enable rapid testing of the ADC. In decimation mode, one data out of 16 is output, thus leading to a maximum output rate of 31.25 Msps.

Note: Frequency (CLKO) = frequency (Data) = Frequency (CLKI)/16.

10.2 Die Junction Temperature Monitoring Function

A die junction temperature measurement setting is included on the board for junction temperature monitoring.

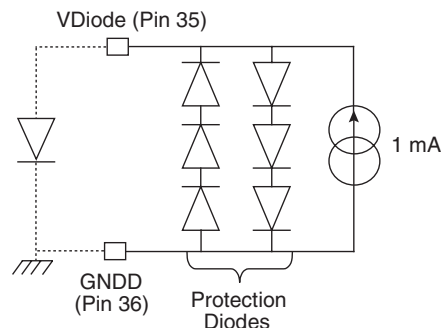
The measurement method forces a 1 mA current into a diode-mounted transistor.

Caution should be given to respecting the polarity of the current.

In any case, one should make sure the maximum voltage compliance of the current source is limited to a maximum of 1V or use a resistor serial-mounted with the current source to avoid damaging the transistor device (this may occur if the current source is reverse-connected).

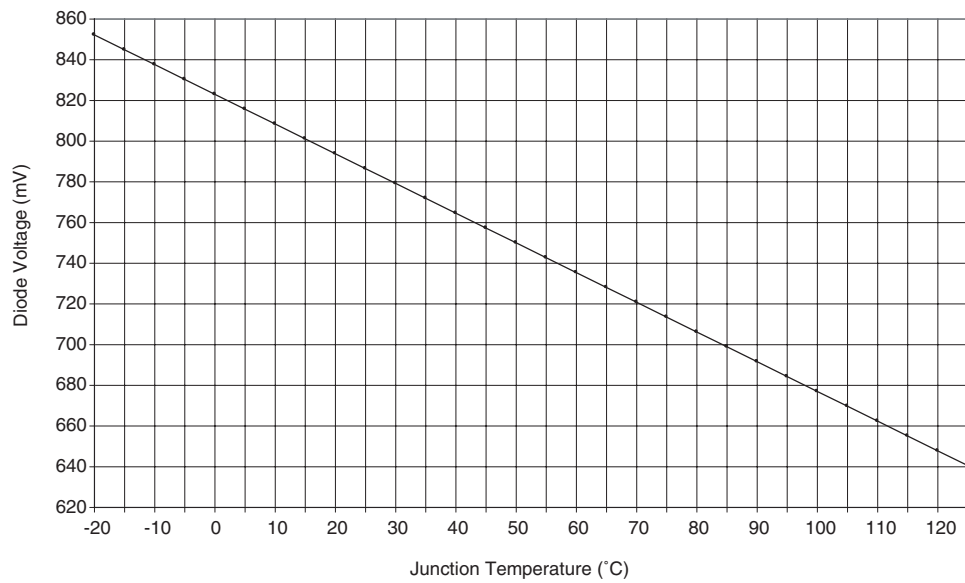
The measurement setup is illustrated in [Figure 10-4](#).

Figure 10-4. Die Junction Temperature Monitoring Setup



The VBE diode's forward voltage in relation to the junction temperature (in steady-state conditions) is shown in [Figure 10-5](#).

Figure 10-5. Diode Characteristics Versus T_J



10.3 VtestI, VtestQ

VtestI and VtestQ pins are for internal test use only. These two signals must be left open.

11. Equivalent Input/Output Schematics

Figure 11-1. Simplified Input Clock Model

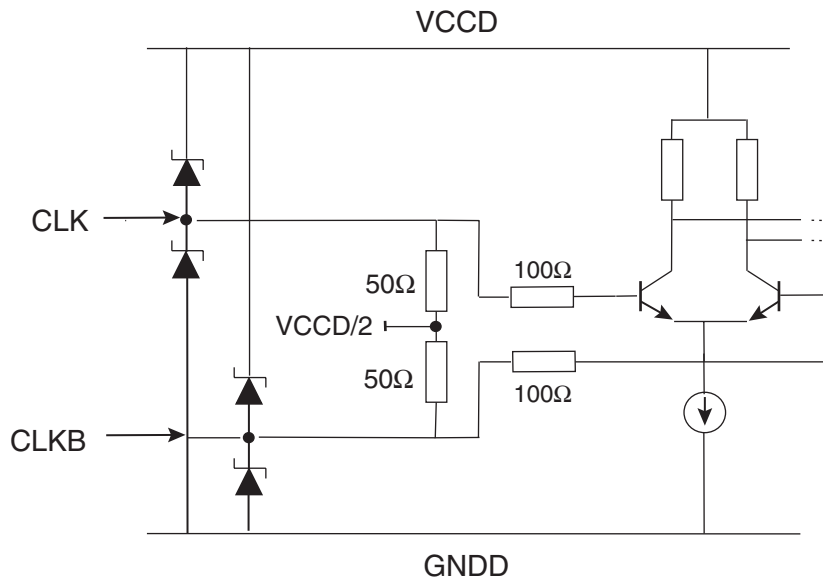


Figure 11-2. Simplified Data Ready Reset Buffer Model

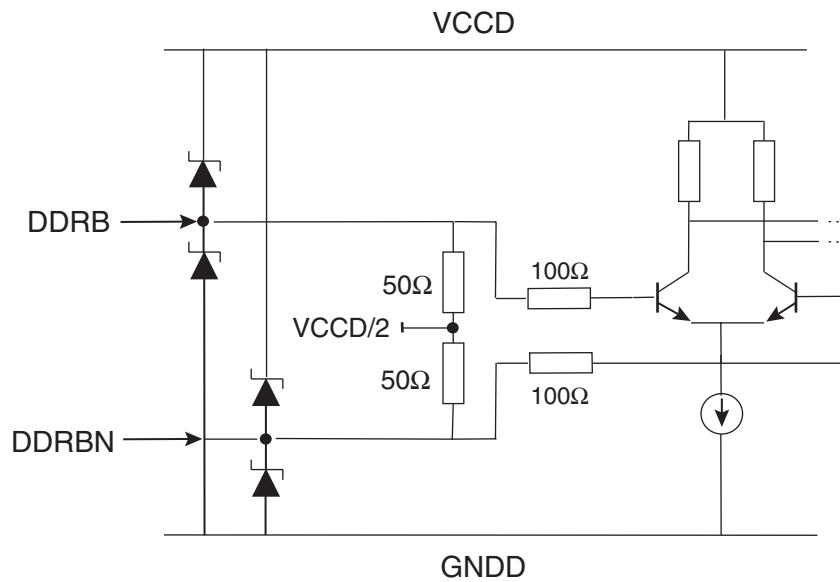


Figure 11-3. Analog Input Model

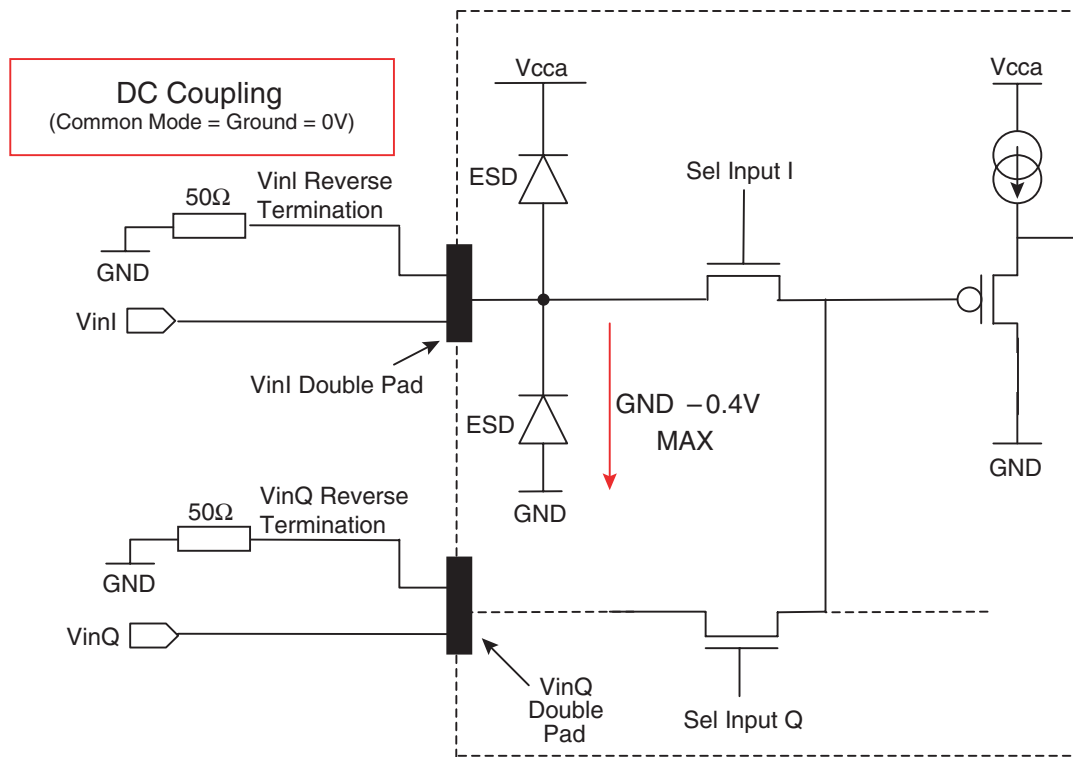
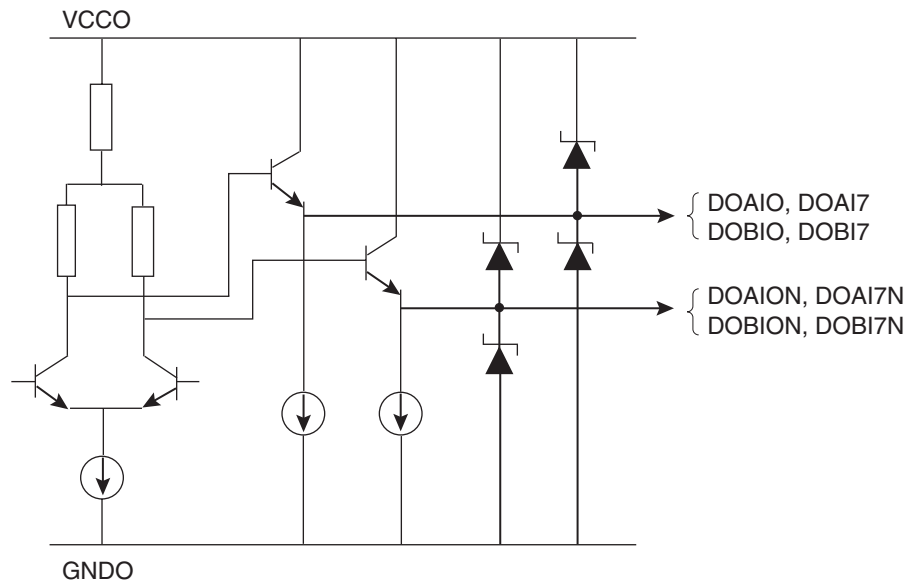


Figure 11-4. Data Output Buffer Model



12. Definitions of Terms

Table 12-1. Definitions of Terms

Abbreviation	Definition	Description
BER	Bit Error Rate	The probability of an error occurring on the output at a maximum sampling rate.
DNL	Differential Non-Linearity	The differential non-linearity for an output code <i>i</i> is the difference between the measured step size of code <i>i</i> and the ideal LSB step size. DNL (<i>i</i>) is expressed in LSBs. DNL is the maximum value of all DNL (<i>i</i>). A DNL error specification of less than 1 LSB guarantees that there are no missing output codes and that the transfer function is monotonic
ENOB	Effective Number of Bits	$ENOB = \frac{SINAD - 1,76 + 20 \log \left[\frac{A}{F_s/2} \right]}{6,02}$ Where A is the actual input amplitude and <i>F_s</i> is the full scale range of the ADC under test
FPBW	Full Power Input Bandwidth	The analog input frequency at which the fundamental component in the digitally reconstructed output waveform has fallen by 3 dB with respect to its low frequency value (determined by FFT analysis) for input at full-scale -1 dB (-1 dBFS)
IMD	Inter-Modulation Distortion	The two tones intermodulation distortion (IMD) rejection is the ratio of either of the two input tones to the worst third order intermodulation products
INL	Integral Non-Linearity	The integral non-linearity for an output code <i>i</i> is the difference between the measured input voltage at which the transition occurs and the ideal value of this transition. INL (<i>i</i>) is expressed in LSBs and is the maximum value of all INL (<i>i</i>)
JITTER	Aperture uncertainty	The sample-to-sample variation in aperture delay. The voltage error due to jitters depends on the slew rate of the signal at the sampling point
NPR	Noise Power Ratio	The NPR is measured to characterize the ADC's performance in response to broad bandwidth signals. When applying a notch-filtered broadband white noise signal as the input to the ADC under test, the Noise Power Ratio is defined as the ratio of the average out-of-notch to the average in-notch power spectral density magnitudes for the FFT spectrum of the ADC output sample test
ORT	Overtoltage Recovery Time	The time to recover a 0.2% accuracy at the output, after a 150% full-scale step applied on the input is reduced to midscale
PSRR	Power Supply Rejection Ratio	The ratio of input offset variation to a change in power supply voltage
SFDR	Spurious Free Dynamic Range	The ratio expressed in dB of the RMS signal amplitude, set at 1 dB below full-scale, to the RMS value of the highest spectral component (peak spurious spectral component). The peak spurious component may or may not be a harmonic. It may be reported in dB (related to the converter -1 dB full-scale) or in dBc (related to the input signal level)
SINAD	Signal to Noise and Distortion Ratio	The ratio expressed in dB of the RMS signal amplitude, set to 1 dB below full-scale (-1 dBFS) to the RMS sum of all other spectral components including the harmonics, except DC
SNR	Signal to Noise Ratio	The ratio expressed in dB of the RMS signal amplitude, set to 1 dB below full-scale, to the RMS sum of all other spectral components excluding the first 9 harmonics
SSBW	Small Signal Input Bandwidth	The analog input frequency at which the fundamental component in the digitally reconstructed output waveform has fallen by 3 dB with respect to its low frequency value (determined by FFT analysis) for input at full-scale -10 dB (-10 dBFS)
TA	Aperture delay	The delay between the rising edge of the differential clock inputs (CLK, CLKB) [zero crossing point] and the time at which VIN and VINB are sampled
TC	Encoding Clock period	TC1 = minimum clock pulse width (high) TC = TC1 + TC2 TC2 = minimum clock pulse width (low)

Table 12-1. Definitions of Terms (Continued)

Abbreviation	Definition	Description
TD1	Time Delay from Data Transition to Data Ready	The general expression is $TD1 = TC1 + TDR - TDO$ with $TC = TC1 + TC2 = 1$ encoding clock period
TD2	Time Delay from Data Ready to Data	The general expression is $TD2 = TC2 + TDR - TDO$ with $TC = TC1 + TC2 = 1$ encoding clock period
TDO	Digital Data Output Delay	The delay from the rising edge of the differential clock inputs (CLK, CLKB) [zero crossing point] to the next point of change in the differential output data (zero crossing) with a specified load
TDR	Data Ready Output Delay	The delay from the falling edge of the differential clock inputs (CLK, CLKB) [zero crossing point] to the next point of change in the differential output data (zero crossing) with a specified load
TF	Fall Time	The time delay for the output data signals to fall from 20% to 80% of delta between the low and high levels
THD	Total Harmonic Distortion	The ratio expressed in dB of the RMS sum of the first 9 harmonic components to the RMS input signal amplitude, set at 1 dB below full-scale. It may be reported in dB (related to the converter -1 dB full-scale) or in dBc (related to the input signal level)
TPD	Pipeline Delay	The number of clock cycles between the sampling edge of an input data and the associated output data made available (not taking into account the TDO)
TR	Rise Time	The time delay for the output data signals to rise from 20% to 80% of delta between the low and high levels
TRDR	Data Ready Reset Delay	The delay between the falling edge of the Data Ready output asynchronous reset signal (DDRB) and the reset to digital zero transition of the Data Ready output signal (DR)
TS	Settling Time	The time delay to rise from 10% to 90% of the converter output when a full-scale step function is applied to the differential analog input
VSWR	Voltage Standing Wave Ratio	The VSWR corresponds to the ADC input insertion loss due to input power reflection. For example, a VSWR of 1.2 corresponds to a 20 dB return loss (99% power transmitted and 1% reflected)

13. Using the AT84AD004B Dual 8-bit 500 Msps ADC

13.1 Decoupling, Bypassing and Grounding of Power Supplies

The following figures show the recommended bypassing, decoupling and grounding schemes for the dual 8-bit 500 Msps ADC power supplies.

Figure 13-1. V_{CCD} and V_{CCA} Bypassing and Grounding Scheme

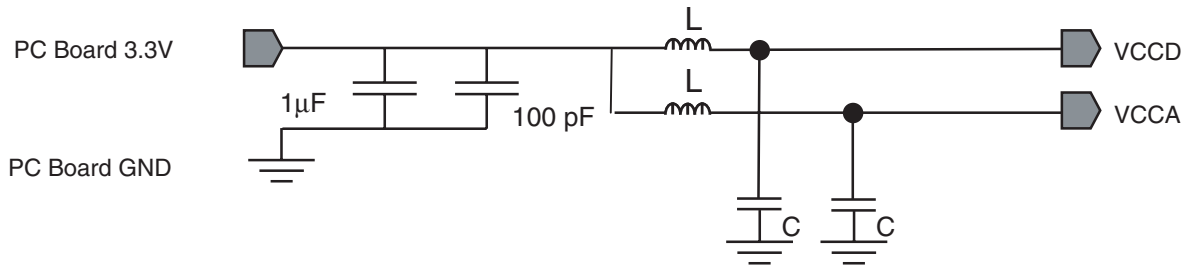
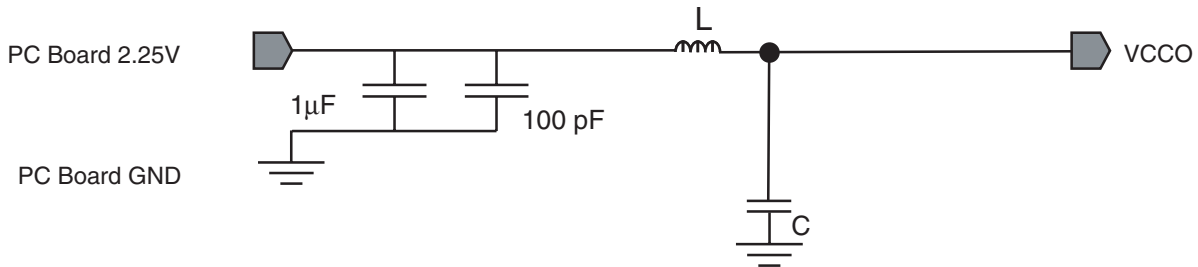
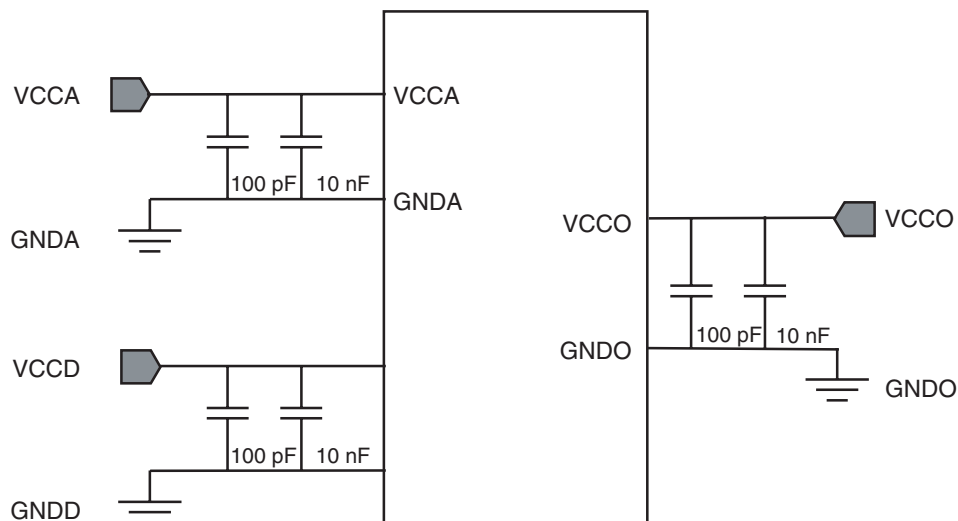


Figure 13-2. V_{CCO} Bypassing and Grounding Scheme



Note: L and C values must be chosen in accordance with the operating frequency of the application.

Figure 13-3. Power Supplies Decoupling Scheme



Note: The bypassing capacitors (1 μ F and 100 pF) should be placed as close as possible to the board connectors, whereas the decoupling capacitors (100 pF and 10 nF) should be placed as close as possible to the device.

13.2 Analog Input Implementation

The analog inputs of the dual ADC have been designed with a double pad implementation as illustrated in Figure 13-4. The reverse pad for each input should be tied to ground via a 50Ω resistor.

The analog inputs must be used in differential mode only.

Figure 13-4. Termination Method for the ADC Analog Inputs in DC Coupling Mode

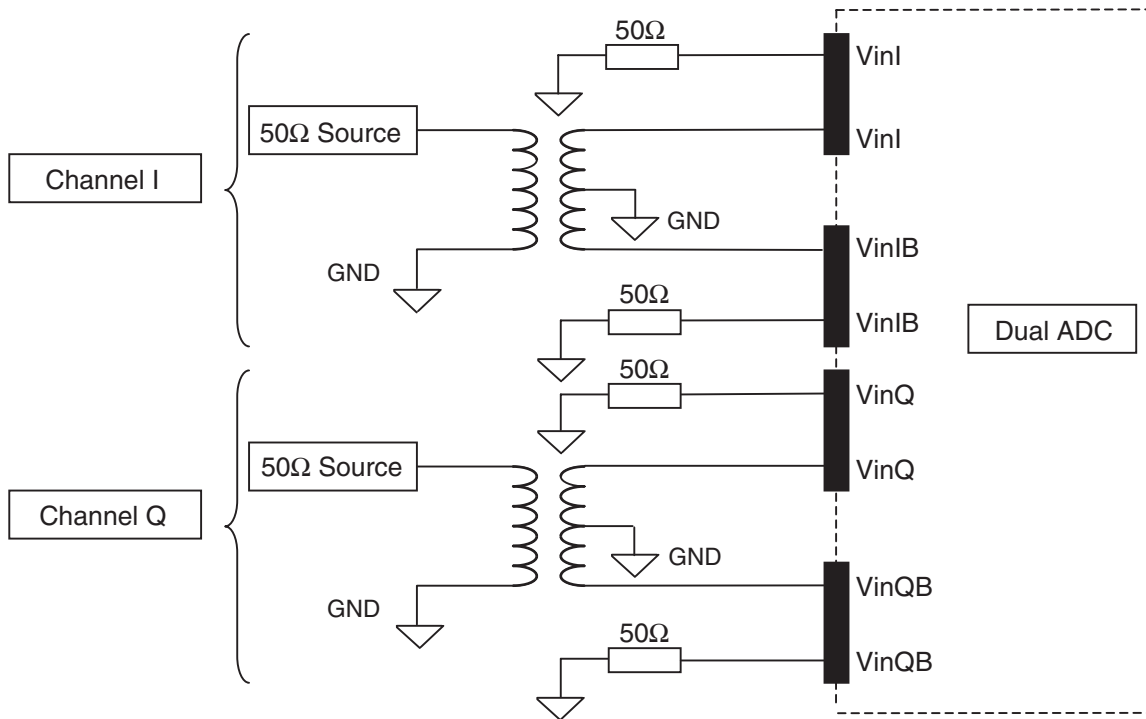
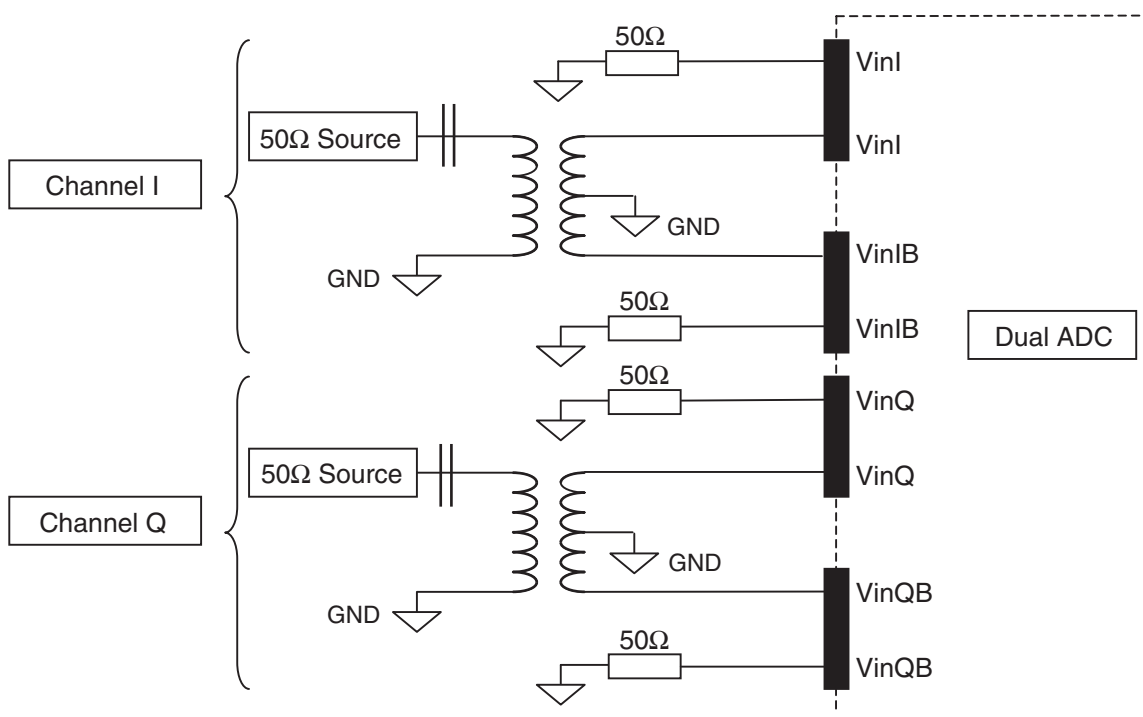


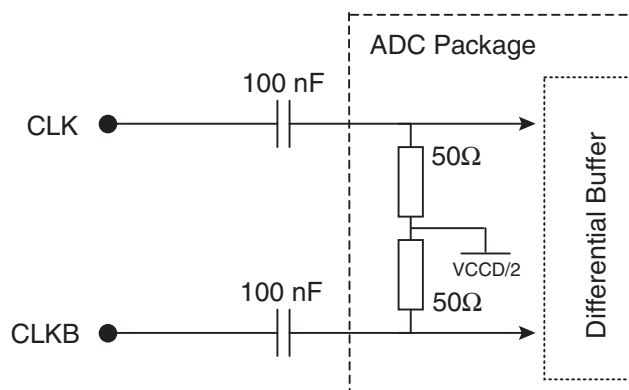
Figure 13-5. Termination Method for the ADC Analog Inputs in AC Coupling Mode



13.3 Clock Implementation

The ADC features two different clocks (I or Q) that must be implemented as shown in [Figure 13-6](#). Each path must be AC coupled with a 100 nF capacitor.

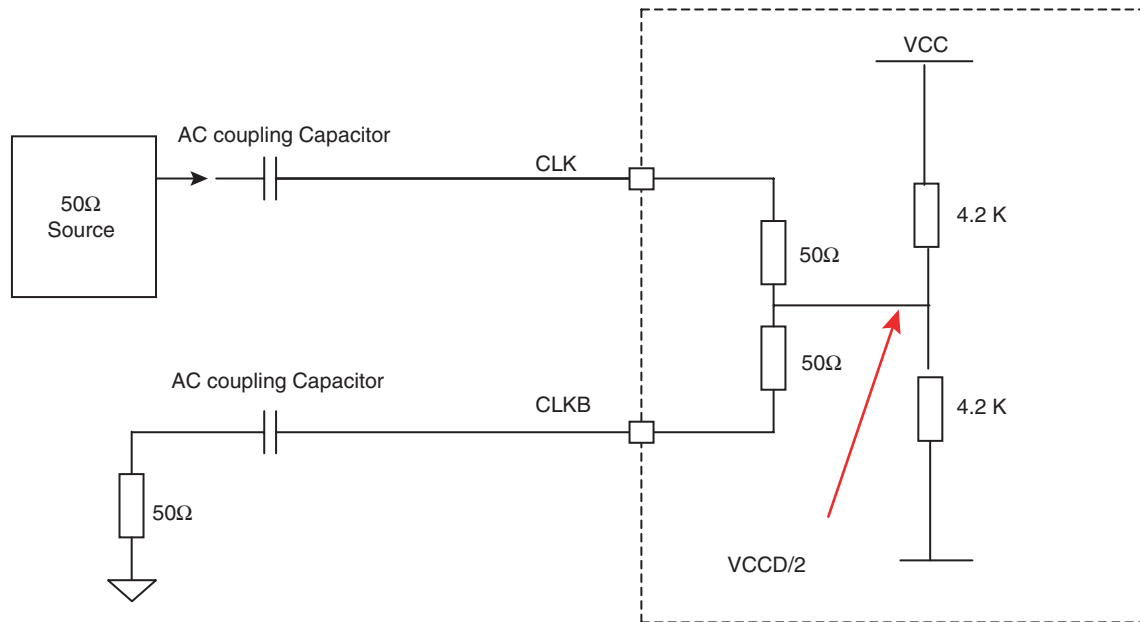
Figure 13-6. Differential Termination Method for Clock I or Clock Q



Note: When only clock I is used, it is not necessary to add the capacitors on the CLKQ and CLKQN signal paths; they may be left floating.

DDRB may be implemented as described in the following figure. A pull-up resistor is implemented to maintain the DDRB signal inactive in normal mode. The Data Ready Reset command (it may be a pulse) is active on the high level.

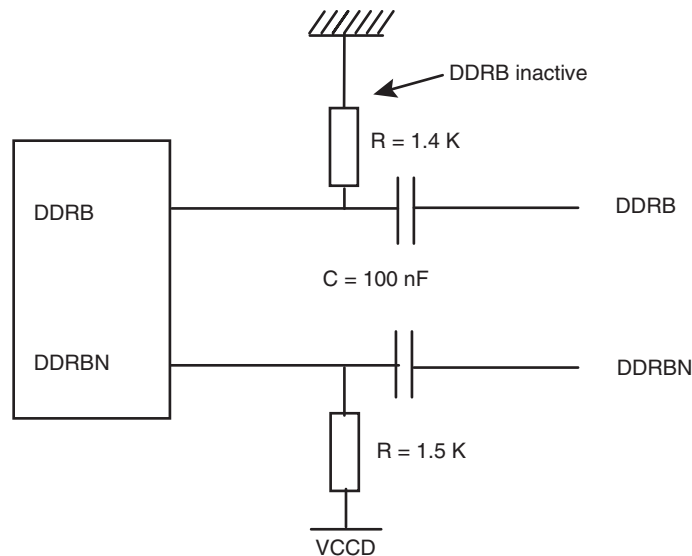
Figure 13-7. Single-ended Termination Method for Clock I or Clock Q



13.4 Reset Implementation

DDRB may be implemented as described in the following figure. A pull-up resistor is implemented to maintain the DDRB signal inactive in normal mode. The Data Ready Reset command (it might be a pulse) is active on the high level.

Figure 13-8. Reset Implementation



13.5 Output Termination in 1:1 Ratio

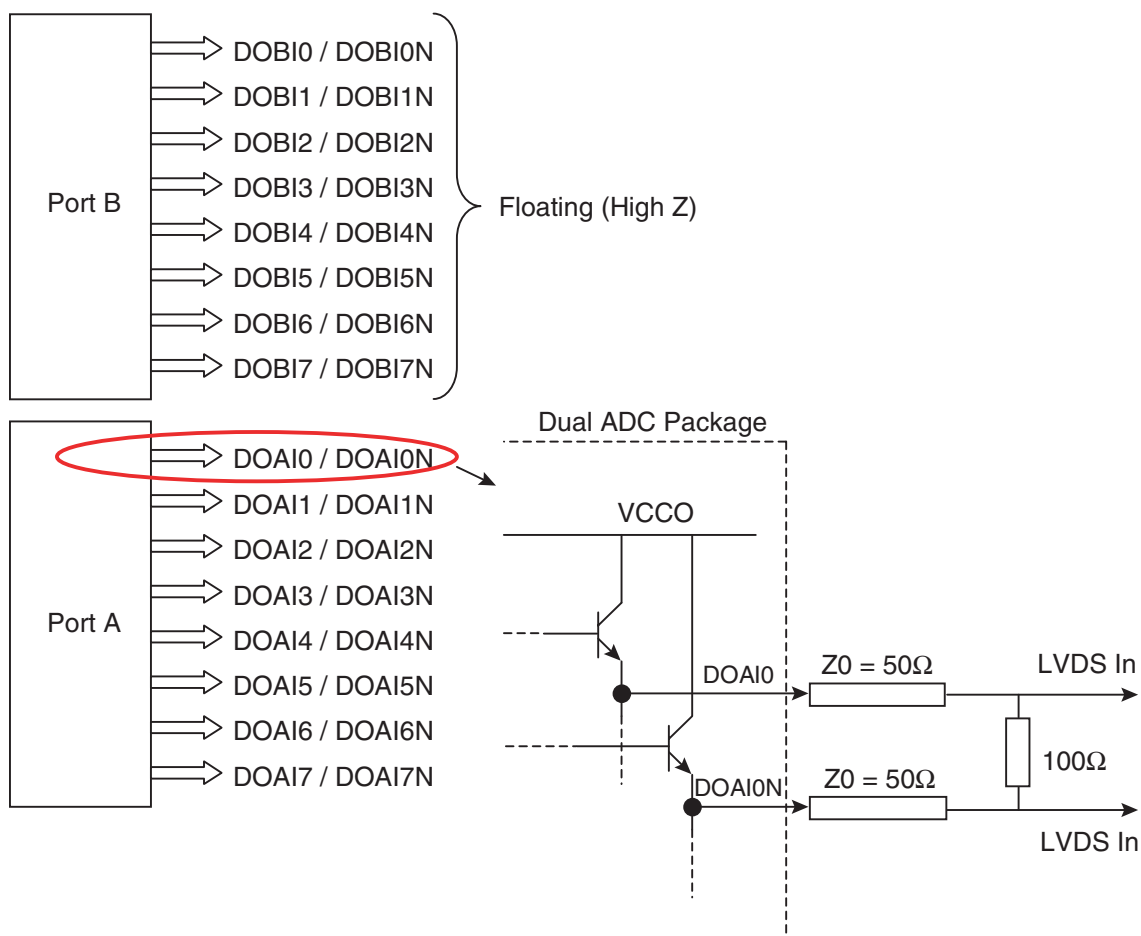
When using the integrated DMUX in 1:1 ratio, the valid port is port A. Port B remains unused.

Port A functions in LVDS mode and the corresponding outputs (DOAI or DOAQ) have to be 100Ω differentially terminated as shown in [Figure 13-9 on page 53](#).

The pins corresponding to Port B (DOBI or DOBQ pins) must be left floating (in high impedance state).

[Figure 13-9 on page 53](#) is an example of a 1:1 ratio of the integrated DMUX for channel I (the same applies to channel Q).

Figure 13-9. Example of Termination for Channel I Used in DMUX 1:1 Ratio (Port B Unused)

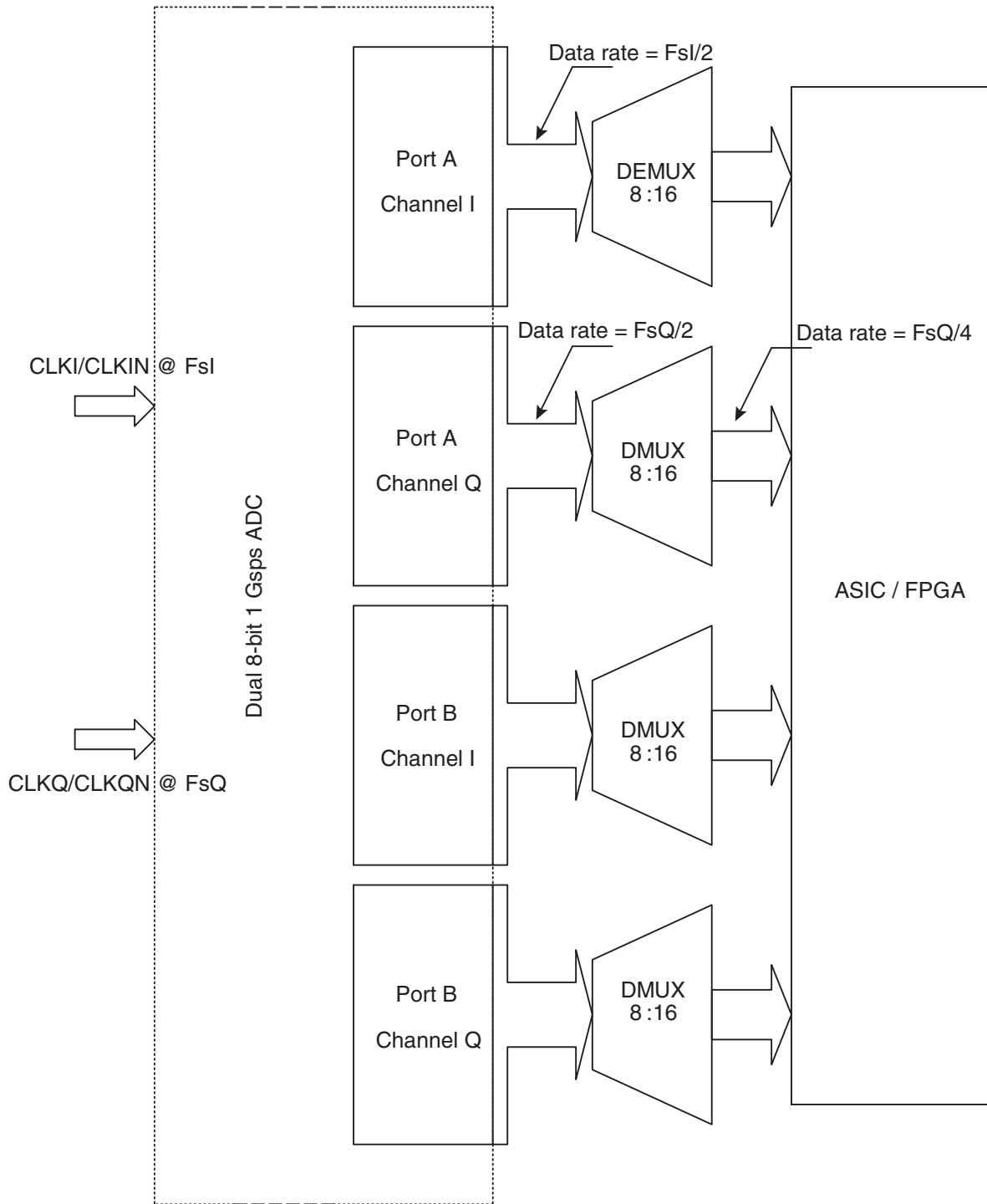


Note: If the outputs are to be used in single-ended mode, it is recommended that the true and false signals be terminated with a 50Ω resistor.

13.6 Using the Dual ADC With and ASIC/FPGA Load

[Figure 13-10 on page 55](#) illustrates the configuration of the dual ADC (1:2 DMUX mode, independent I and Q clocks) driving an LVDS system (ASIC/FPGA) with potential additional DMUXes used to halve the speed of the dual ADC outputs.

Figure 13-10. Dual ADC and ASIC/FPGA Load Block Diagram



Note: The demultiplexers may be internal to the ASIC/FPGA system.

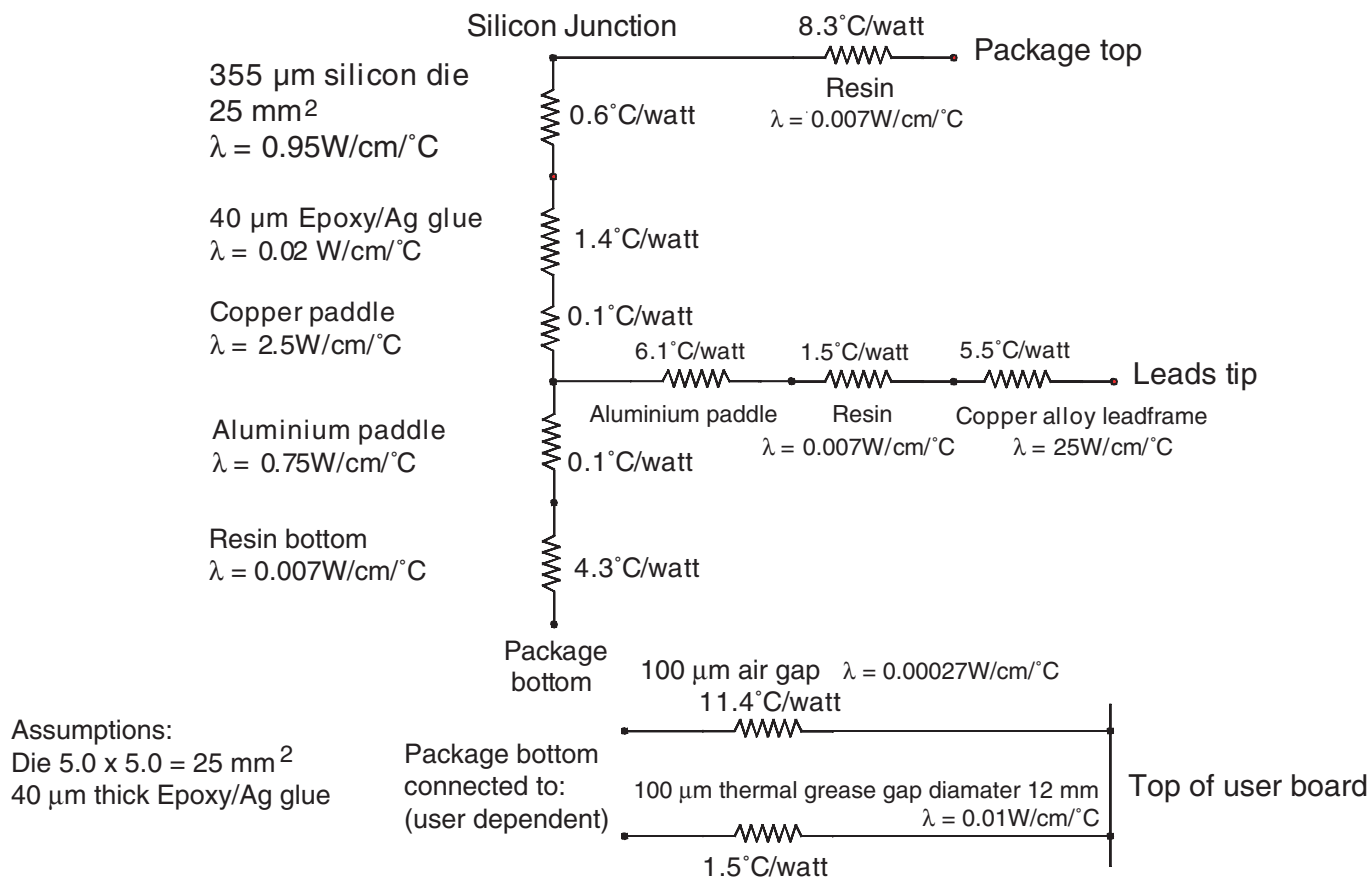
14. Thermal Characteristics

14.1 Simplified Thermal Model for LQFP 144 (20 x 20 x 1.4 mm)

The following model has been extracted from the ANSYS FEM simulations.

Assumptions: no air, no convection and no board.

Figure 14-1. Simplified Thermal Model for LQFP Package



Note: The above are typical values with an assumption of uniform power dissipation over 2.5 x 2.5 mm² of the top surface of the die.

14.1.0.1 Thermal Resistance from Junction to Bottom of Leads

Assumptions: no air, no convection and no board.

The thermal resistance from the junction to the bottom of the leads is 15.2°C/W typical.

14.1.0.2 Thermal Resistance from Junction to Top of Case

Assumptions: no air, no convection and no board.

The thermal resistance from the junction to the top of the case is 8.3°C/W typical.

14.1.0.3 Thermal Resistance from Junction to Bottom of Case

Assumptions: no air, no convection and no board.

The thermal resistance from the junction to the bottom of the case is 6.4°C/W typical.

14.1.0.4 Thermal Resistance from Junction to Bottom of Air Gap

The thermal resistance from the junction to the bottom of the air gap (bottom of package) is 17.9°C/W typical.

14.1.0.5 Thermal Resistance from Junction to Ambient

The thermal resistance from the junction to ambient is 25.2°C/W typical.

Note: In order to keep the ambient temperature of the die within the specified limits of the device grade (that is T_{amb} max = 70°C in commercial grade and 85°C in industrial grade) and the die junction temperature below the maximum allowed junction temperature of 105°C, it is necessary to operate the dual ADC in air flow conditions (1m/s recommended).

In still air conditions, the junction temperature is indeed greater than the maximum allowed T_J .

- $T_J = 25.2^\circ\text{C/W} \times 1.4\text{W} + T_{amb} = 35.28 + 70 = 105.28^\circ\text{C}$ for commercial grade devices

- $T_J = 25.2^\circ\text{C/W} \times 1.4\text{W} + T_{amb} = 35.28 + 85 = 125.28^\circ\text{C}$ for industrial grade devices

14.1.0.6 Thermal Resistance from Junction to Board

The thermal resistance from the junction to the board is 13°C/W typical.

14.2 LQFP-ep 144L Green Package Thermal Characteristics

14.2.1 Thermal Resistance from Junction to Ambient

Simulations (JEDEC JESD51 standard) were held with the following assumptions:

- Board with 76.2 mm x 114.3 mm dimensions
- Still air
- Exposed pad (5.8 x 5.8 mm) soldered to the board

The thermal resistance from the junction to ambient is 25.0 °C/W.

Note: When the exposed pad is not soldered to the board, the R_{thj-a} becomes 58.8°C/W.

14.2.2 Exposed Pad Board layout Recommendation

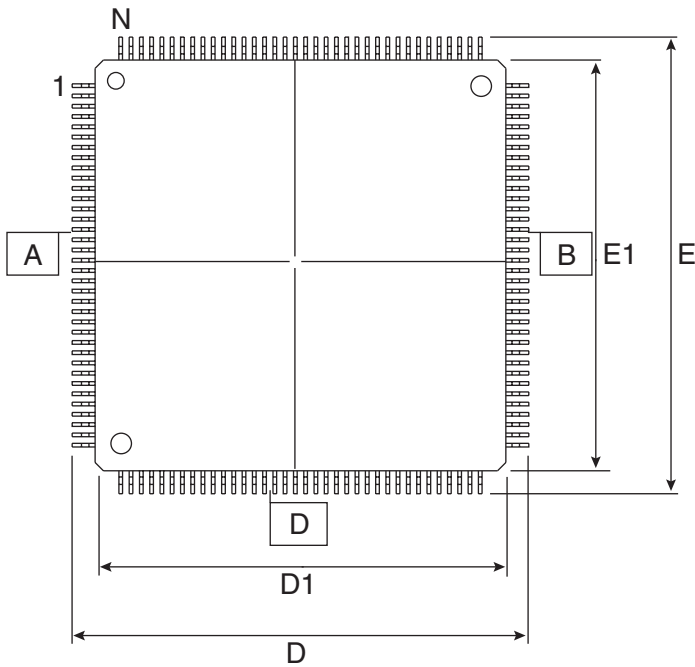
It is recommended to solder the exposed pad of the LQFP-ep 144L package to the board via a 5.8 x 5.8 mm ground pad.

15. Ordering Information

Part Number	Package	Temperature Range	Screening	Comments
AT84AD004BCTD	LQFP 144	C grade $0^{\circ}\text{C} < T_{\text{amb}} < 70^{\circ}\text{C}$	Standard	
AT84AD004BVTD	LQFP 144	V grade $-40^{\circ}\text{C} < T_{\text{amb}} < 85^{\circ}\text{C}$	Standard	
AT84AD004BCTDW	LQFP-ep 144L green (RoHS compliant)	C grade $0^{\circ}\text{C} < T_{\text{amb}} < 70^{\circ}\text{C}$	Standard	Please contact your local e2v sales office
AT84AD004BVTDW	LQFP-ep 144L green (RoHS compliant)	V grade $-40^{\circ}\text{C} < T_{\text{amb}} < 85^{\circ}\text{C}$	Standard	Please contact your local e2v sales office
AT84AD004TD-EB	LQFP 144	Ambient	Prototype	Evaluation kit

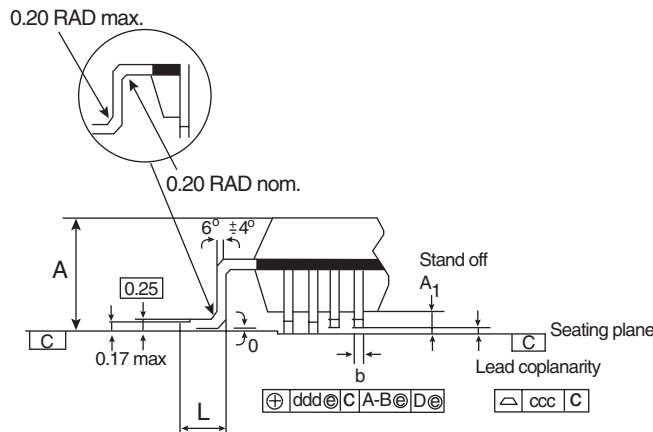
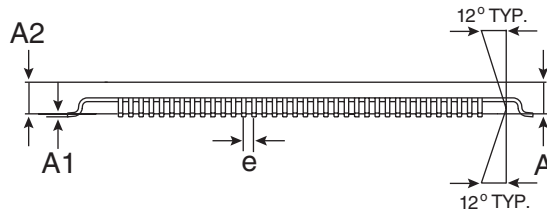
16. Packaging Information

Figure 16-1. LQFP 144 Package



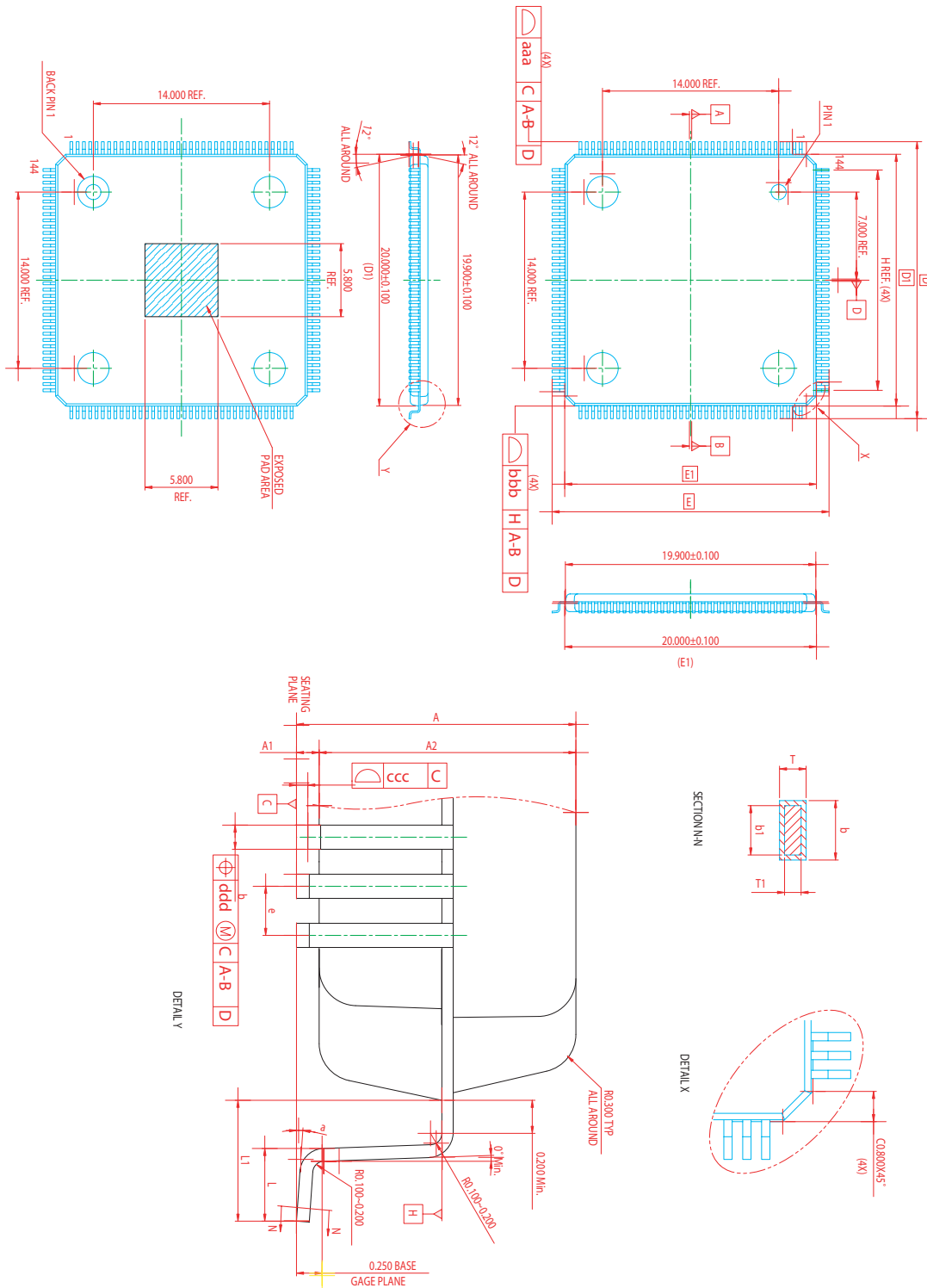
Body +2.00 mm footprint			
Dims.	Tols.	Leads	144L
A	max.		1.60
A1			0.05 min./0.15 max.
A2	+/- 0.05		1.40
D	+/-0.20		22.00
D1	+/-0.10		20.00
E	+/-0.20		22.00
E1	+/-0.10		20.00
L	+0.15/-0.10		0.60
e	basic		0.50
b	+/-0.05		0.22
ddd			0.08
ccc	max.		0.08
o			0°- 5°

- Notes:
1. All dimensions are in millimeters
 2. Dimensions shown are nominal with tolerances as indicated
 3. L/F: etfec 64T copper or equivalent
 4. Foot length: "L" is measured at gauge plane at 0.25 mm above the seating plane



Note: Thermally enhanced package: LQFP 144, 20 x 20 x 1.4 mm.

Figure 16-2. LQFP-ep 144L Green Package



DIMENSION LIST (FOOTPRINT: 2.00)

S/N	SYM	DIMENSIONS	REMARKS
1	A	MAX. 1.600	OVERALL HEIGHT
2	A1	0.100±0.050	STANDOFF
3	A2	1.400±0.050	PKG THICKNESS
4	D	22.000±0.200	LEAD TIP TO TIP
5	D1	20.000±0.100	PKG LENGTH
6	E	22.000±0.200	LEAD TIP TO TIP
7	E1	20.000±0.100	PKG WIDTH
8	L	0.600±0.150	FOOT LENGTH
9	L1	1.000 REF.	LEAD LENGTH
10	T	0.150 ^{+0.050} _{0.060}	LEAD THICKNESS
11	T1	0.127±0.030	LEAD BASE METAL THICKNESS
12	a	0°~7°	FOOT ANGLE
13	b	0.220±0.050	LEAD WIDTH
14	b1	0.200±0.030	LEAD BASE METAL WIDTH
15	e	0.500 BASE	LEAD PITCH
16	H (REF.)	(17.500)	CUM. LEAD PITCH
17	aaa	0.200	PROFILE OF LEAD TIPS
18	bbb	0.200	PROFILE OF MOLD SURFACE
19	ccc	0.080	FOOT COPLANARITY
20	ddd	0.080	FOOT POSITION

NOTES:

S/N	DESCRIPTION	SPECIFICATION	
1	GENERAL TOLERANCE.	DISTANCE	±0.100
		ANGLE	±2.5°
2	MATTE FINISH ON PACKAGE BODY SURFACE EXCEPT EJECTION AND PIN 1 MARKING.	Ra0.8~2.0um	
3	ALL MOLDED BODY SHARP CORNER RADII UNLESS OTHERWISE SPECIFIED.	MAX. R0.200	
4	PACKAGE/LEADFRAME MISALIGNMENT (X, Y):	MAX. 0.127	
5	TOP/BTM PACKAGE MISALIGNMENT (X, Y):	MAX. 0.127	
6	DRAWING DOES NOT INCLUDE PLASTIC OR METAL PROTRUSION OR CUTTING BURR.		
7	COMPLIANT TO JEDEC STANDARD:	MS-026	

FOR HIGH DENSITY STRIP LAYOUT

Table of Contents

1	Features	1
2	Performance	1
3	Application	1
4	Description	2
5	Functional Description	2
6	Typical Applications	4
6.1	Absolute Maximum Ratings	5
6.2	Recommended Conditions of Use	6
7	Electrical Operating Characteristics	6
7.1	Timing Diagrams	12
7.2	Functions Description	19
7.3	Digital Output Coding (Nominal Settings)	20
8	Pin Description	20
9	Typical Characterization Results	23
9.1	Typical Full Power Input Bandwidth	23
9.2	Typical Crosstalk	24
9.3	Typical DC, INL and DNL Patterns	24
9.4	Typical Dynamic Performances Versus Sampling Frequency	25
9.5	Typical Dynamic Performances Versus Input Frequency	27
9.6	Typical Signal Spectrum	29
9.7	Typical Performance Sensitivity Versus Power Supplies and Temperature	31
10	Test and Control Features	35
10.1	3-wire Serial Interface Control Setting	35
10.2	Die Junction Temperature Monitoring Function	43
10.3	VtestI, VtestQ	44
11	Equivalent Input/Output Schematics	45
12	Definitions of Terms	47
13	Using the AT84AD004B Dual 8-bit 500 Msps ADC	49
13.1	Decoupling, Bypassing and Grounding of Power Supplies	49

13.2	Analog Input Implementation	50
13.3	Clock Implementation	51
13.4	Reset Implementation	52
13.5	Output Termination in 1:1 Ratio	53
13.6	Using the Dual ADC With and ASIC/FPGA Load	54
14	<i>Thermal Characteristics</i>	56
14.1	Simplified Thermal Model for LQFP 144 (20 x 20 x 1.4 mm)	56
14.2	LQFP-ep 144L Green Package Thermal Characteristics	57
15	<i>Ordering Information</i>	58
16	<i>Packaging Information</i>	59



How to reach us

Home page: www.e2v.com

Sales Office:

United Kingdom

e2v
106 Waterhouse Lane
Chelmsford
Essex CM1 2QU
Tel +44 (0)1245 493 493
Fax +44 (0)1245 492 492

USA

e2v
4 Westchester Plaza
Elmsford
NY 10523-1482
Tel +1 914 592 6050
Fax +1 914 592 5148

France

e2v
16 Burospace
F-91 572 Bievres Cedex
Tel +33 (0) 1 6019 5500
Fax +33 (0) 1 6019 5529

Product Contact:

e2v
Avenue de Rochepleine
BP 123 - 38521 Saint-Egrève Cedex
France
Tel. +33 (0)4 76 58 30 00

Hotline:

hotline-bdc@e2v.com

Whilst e2v has taken care to ensure the accuracy of the information contained herein it accepts no responsibility for the consequences of any use thereof and also reserves the right to change the specification of goods without notice. e2v accepts no liability beyond that set out in its standard conditions of sale in respect of infringement of third party patents arising from the use of tubes or other devices in accordance with information contained herein.