

8-BIT D/A CONVERTERS

The KDA0808 series is an 8-bit monolithic digital-to-analog converter featuring a full-scale output current settling time of 150ns while dissipating only 33mW with $\pm 5V$ supply voltages. No reference current (I_{ref}) trimming is required for most applications since the full scale output current error is typically $\pm 1LSB$ of $255I_{ref}/256$. Linearity errors of better than $\pm 0.19\%$ assure 8-bit monotonicity and linearity while a zero-level output current of less than $4\mu A$ provides a 0.19% zero linearity error for $I_{ref} \geq 2mA$. The power supply currents of the KDA0808 series are independent of bit codes and exhibit essentially constant device characteristics over the entire supply voltage range. The KDA0808 will interface directly with popular TTL, DTL or CMOS logic levels, and is a direct replacement for the MC1408/MC1508/DAC0808.

16-DIP-300A

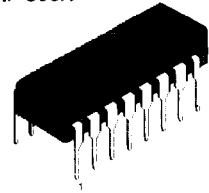

16-SOP-225

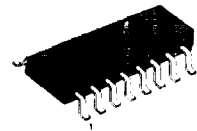

FEATURES

- Relative accuracy: $\pm 0.19\%$ error max (KDA0808)
- Full scale current error: $\pm 1LSB$ typ
- $\pm 1LSB$ non-linearity available (KDA0807)
- Fast settling time: 150ns typ
- Noninverting digital inputs are TTL and CMOS compatible
- Power supply voltage range: $\pm 4.5 \sim \pm 18V$
- Low power consumption: 33mW at $\pm 5V$

ORDERING INFORMATION

Device	Package	Temperature Range	Nonlinearity
KDA0808CN/CD	16DIP/16SOP	0 ~ +70°C	$\pm 0.19\%$ FS
KDA0807CN/CD			$\pm 0.39\%$ FS

BLOCK DIAGRAM

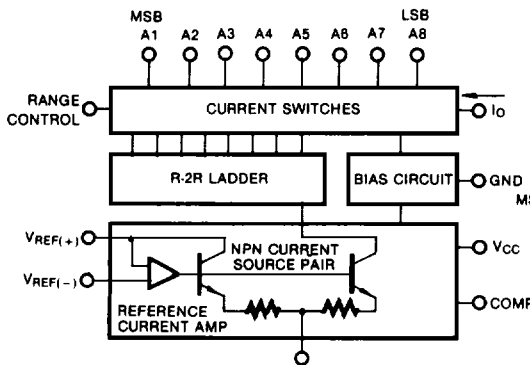

PIN CONFIGURATION

Dual-in-line Package

Small Outline Package

