

MOS INTEGRATED CIRCUIT MC-421000A32, 421000A36 SERIES

1 M-WORD BY 32-BIT, 1 M-WORD BY 36-BIT DYNAMIC RAM MODULE FAST PAGE MODE

Description

The MC-421000A32 series is a 1 048 576 words by 32 bits dynamic RAM module on which 8 pieces of 4 M DRAM : μ PD424400 are assembled.

The MC-421000A36 series is a 1 048 576 words by 36 bits dynamic RAM module on which 8 pieces of 4 M DRAM : μ PD424400 and 4 pieces of 1 M DRAM : μ PD421000 are assembled.

These modules provide high density and large quantities of memory in a small space without utilizing the surface-mounting technology on the printed circuit board.

Decoupling capacitors are mounted on power supply line for noise reduction.

Features

- 1 048 576 words by 32 bits organization (MC-421000A32 series)
- 1 048 576 words by 36 bits organization (MC-421000A36 series)
- Fast access and cycle time

Family	Access time (MAX.)	R/W cycle time (MIN.)	Power consumption (MAX.)	
			Active	Standby
MC-421000A32-60	60 ns	120 ns	5 040 mW	42 mW (CMOS level input)
MC-421000A32-70	70 ns	140 ns	4 200 mW	
MC-421000A32-80	80 ns	160 ns	3 780 mW	
MC-421000A32-10	100 ns	190 ns	3 360 mW	
MC-421000A36-60	60 ns	120 ns	6 510 mW	63 mW (CMOS level input)
MC-421000A36-70	70 ns	140 ns	5 880 mW	
MC-421000A36-80	80 ns	160 ns	5 250 mW	
MC-421000A36-10	100 ns	190 ns	4 620 mW	

- 1 024 refresh cycles/16 ms
- CAS before $\overline{\text{RAS}}$ refresh, $\overline{\text{RAS}}$ only refresh, Hidden refresh
- 72-pin single in-line memory module (Pin pitch = 1.27 mm)
- Single +5.0 V \pm 5 % power supply
- Access time can be distinguished with characteristics of PD-pins(PD0 to PD3)

The information in this document is subject to change without notice.

Ordering Information

[MC-421000A32 series]

Part number	Access time (MAX.)	Package	Mounted devices
MC-421000A32B-60	60 ns	72-pin Single In-line Memory Module (Socket Type) Edge connector : Solder coating (HAL)	8 pieces of μ PD424400LA (300 mil SOJ) (Single side)
MC-421000A32B-70	70 ns		
MC-421000A32B-80	80 ns		
MC-421000A32B-10	100 ns		
MC-421000A32F-60	60 ns	72-pin Single In-line Memory Module (Socket Type) Edge connector : Gold plating	
MC-421000A32F-70	70 ns		
MC-421000A32F-80	80 ns		
MC-421000A32F-10	100 ns		

[MC-421000A36 series]

Part number	Access time (MAX.)	Package	Mounted devices
MC-421000A36BE-60	60 ns	72-pin Single In-line Memory Module (Socket Type) Edge connector : Solder coating (HAL)	8 pieces of μ PD424400LA (300 mil SOJ) 4 pieces of μ PD421000LA (300 mil SOJ) (Double side)
MC-421000A36BE-70	70 ns		
MC-421000A36BE-80	80 ns		
MC-421000A36BE-10	100 ns		
MC-421000A36FE-60	60 ns	72-pin Single In-line Memory Module (Socket Type) Edge connector : Gold plating	
MC-421000A36FE-70	70 ns		
MC-421000A36FE-80	80 ns		
MC-421000A36FE-10	100 ns		
MC-421000A36BJ-60	60 ns	72-pin Single In-line Memory Module (Socket Type) Edge connector : Solder coating (HAL)	8 pieces of μ PD424400LA (300 mil SOJ) 4 pieces of μ PD421000LA (300 mil SOJ) (Single side)
MC-421000A36BJ-70	70 ns		
MC-421000A36BJ-80	80 ns		
MC-421000A36BJ-10	100 ns		
MC-421000A36FJ-60	60 ns	72-pin Single In-line Memory Module (Socket Type) Edge connector : Gold plating	
MC-421000A36FJ-70	70 ns		
MC-421000A36FJ-80	80 ns		
MC-421000A36FJ-10	100 ns		

Quality Grade

Standard

Please refer to "Quality grade on NEC Semiconductor Devices" (Document number IEI-1209) published by NEC Corporation to know the specification of quality grade on the devices and its recommended applications.

Pin Configurations

[MC-421000A32 series]

72-pin Single In-line Memory Module Socket Type (Edge connector: Solder Coating, Gold Plating)

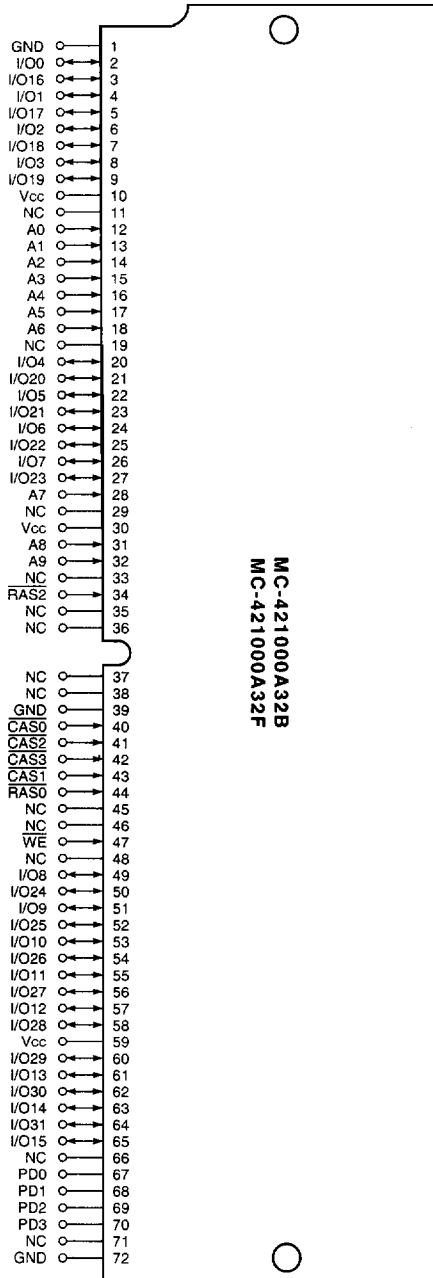

- A0-A9 : Address Inputs
- I/O0-I/O31 : Data Inputs/Outputs
- CAS0-CAS3 : Column Address Strobe
- RAS0, RAS2 : Row Address Strobe
- WE : Write Enable
- Vcc : Power Supply
- GND : Ground
- NC : No connection

The internal connection of PD pins (PD0 - PD3) depends on access time.

Pin Name	Pin No.	Access Time			
		60 ns	70 ns	80 ns	100 ns
PD0	67	GND	GND	GND	GND
PD1	68	GND	GND	GND	GND
PD2	69	NC	GND	NC	GND
PD3	70	NC	NC	GND	GND

[MC-421000A36 series]

72-pin Single In-line Memory Module Socket Type (Edge connector: Solder Coating, Gold Plating)

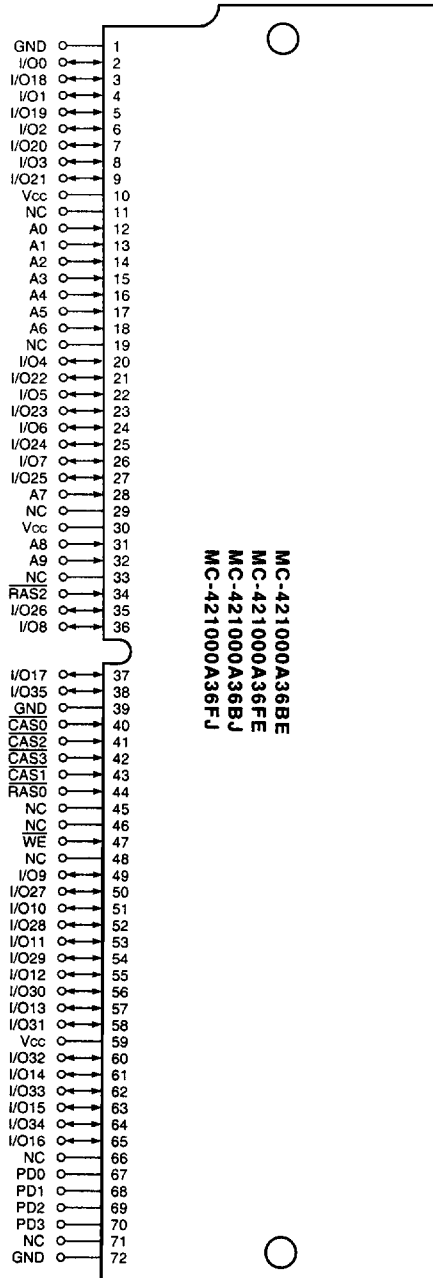

- A0-A9 : Address Inputs
- I/O0-I/O35 : Data Inputs/Outputs
- CAS0-CAS3 : Column Address Strobe
- RAS0, RAS2 : Row Address Strobe
- WE : Write Enable
- Vcc : Power Supply
- GND : Ground
- NC : No connection

The internal connection of PD pins (PD0 - PD3) depends on access time.

Pin Name	Pin No.	Access Time			
		60 ns	70 ns	80 ns	100 ns
PD0	67	GND	GND	GND	GND
PD1	68	GND	GND	GND	GND
PD2	69	NC	GND	NC	GND
PD3	70	NC	NC	GND	GND

Block Diagram

[MC-421000A32 series]

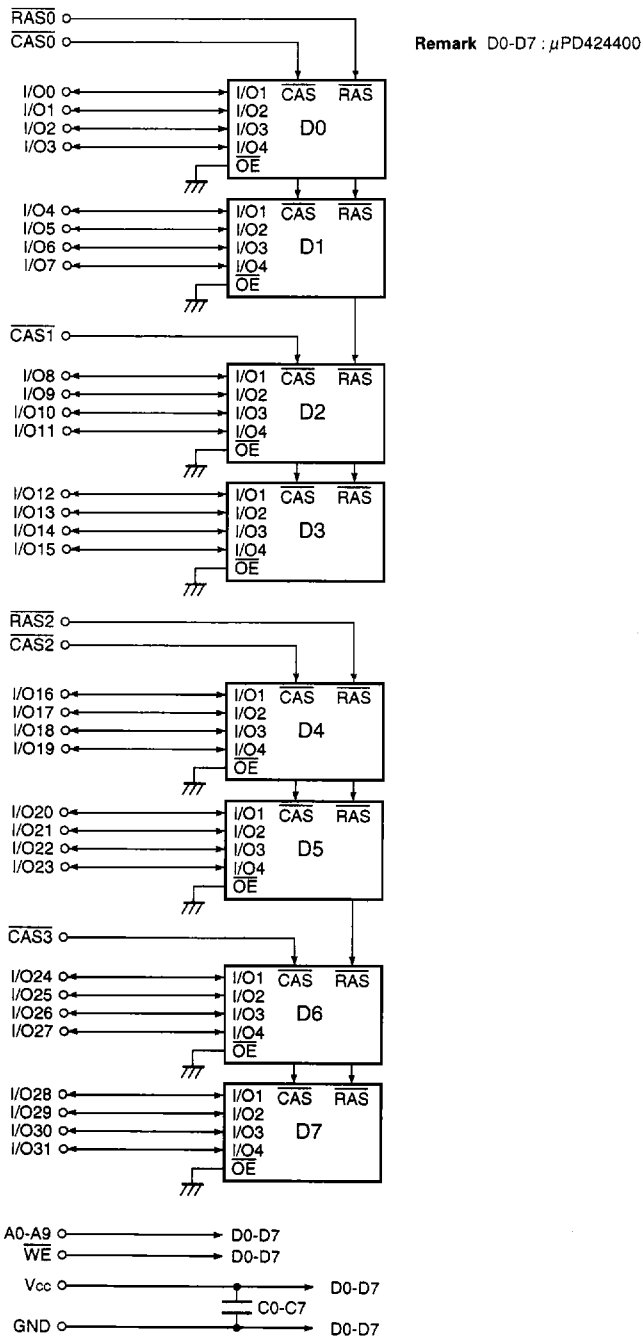

[MC-421000A36 series]

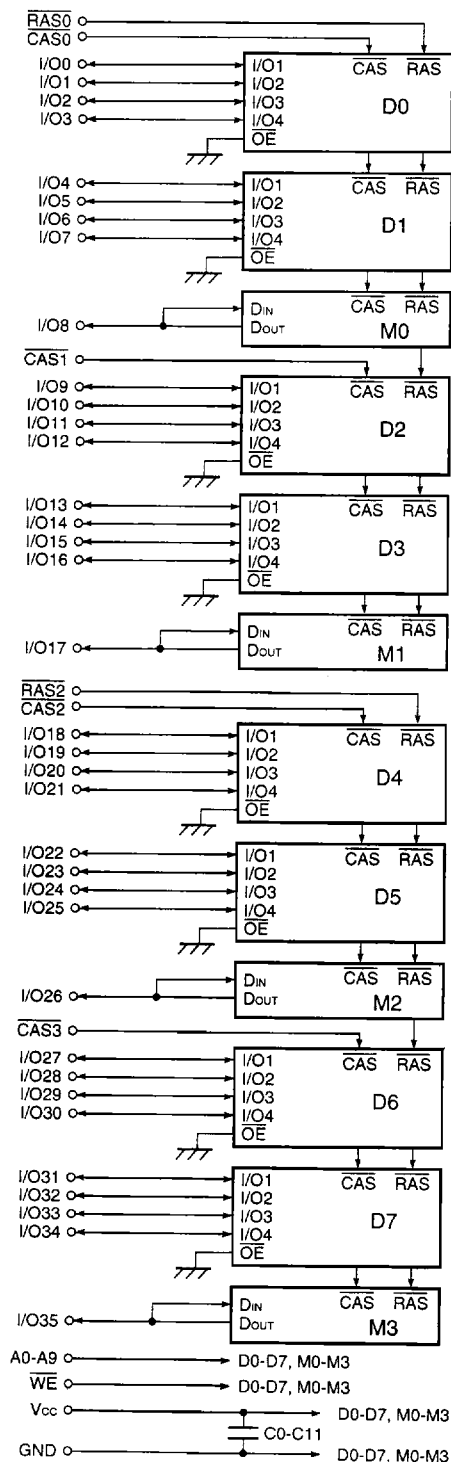

Remark D0-D7 : μ PD424400
M0-M3 : μ PD421000

Electrical Specifications Notes 1, 2

Absolute Maximum Ratings

Parameter	Symbol	Condition	Rating	Unit
Voltage on any pin relative to GND	V _r		-1.0 to +7.0	V
Supply voltage	V _{cc}		-1.0 to +7.0	V
Output current	I _o		50	mA
Power dissipation	P _d	MC-421000A32	8	W
		MC-421000A36	12	
Operating temperature	T _{opt}		0 to +70	°C
Storage temperature	T _{stg}		-55 to +125	°C

Caution Exposing the device to stress above those listed in Absolute Maximum Ratings could cause permanent damage. The device is not meant to be operated under conditions outside the limits described in the operational section of this specification. Exposure to Absolute Maximum Rating conditions for extended periods may affect device reliability.

Recommended Operating Conditions

Parameter	Symbol	Condition	MIN.	TYP.	MAX.	Unit
Supply voltage	V _{cc}		4.75	5.0	5.25	V
High level input voltage	V _{IH}		2.4		V _{cc} +1.0	V
Low level input voltage	V _{IL}		-1.0		+0.8	V
Ambient temperature	T _a		0		70	°C

Capacitance (T_a = +25 °C, f = 1 MHz)

[MC-421000A32 series]

Parameter	Symbol	Test Condition	MIN.	TYP.	MAX.	Unit
Input capacitance	C ₁	A0 - A9			68	pF
	C ₂	\overline{WE}			76	
	C ₃	$\overline{RAS0}, \overline{RAS2}$			43	
	C ₄	$\overline{CAS0} - \overline{CAS3}$			29	
Data Input/Output capacitance	C _{I/O}	I/O0 - I/O31			17	pF

[MC-421000A36 series]

Parameter	Symbol	Test Condition	MIN.	TYP.	MAX.	Unit
Input capacitance	C ₁	A0 - A9			88	pF
	C ₂	\overline{WE}			104	
	C ₃	$\overline{RAS0}, \overline{RAS2}$			57	
	C ₄	$\overline{CAS0} - \overline{CAS3}$			36	
Data Input/Output capacitance	C _{I/O1}	I/O0 - I/O7, I/O9 - I/O16, I/O18 - I/O25, I/O27 - I/O34			17	pF
	C _{I/O2}	I/O8 - I/O17, I/O26, I/O35			22	

DC Characteristics (Recommended Operating Conditions unless otherwise noted)
[MC-421000A32 series]

Parameter	Symbol	Test condition	MIN.	MAX.	Unit	Notes
Operating current	I _{CC1}	$\overline{\text{RAS}}, \overline{\text{CAS}}$ Cycling $\text{trc} = \text{trc}(\text{MIN.})$ $I_o = 0 \text{ mA}$	trAC = 60 ns	960	mA	3,4,7
			trAC = 70 ns	800		
			trAC = 80 ns	720		
			trAC = 100 ns	640		
Standby current	I _{CC2}	$\overline{\text{RAS}}, \overline{\text{CAS}} \geq V_{IH}(\text{MIN.})$ $I_o = 0 \text{ mA}$		16	mA	
		$\overline{\text{RAS}}, \overline{\text{CAS}} \geq V_{CC} - 0.2 \text{ V}$ $I_o = 0 \text{ mA}$		8		
$\overline{\text{RAS}}$ only refresh current	I _{CC3}	$\overline{\text{RAS}}$ Cycling $\overline{\text{CAS}} \geq V_{IH}(\text{MIN.})$ $\text{trc} = \text{trc}(\text{MIN.})$ $I_o = 0 \text{ mA}$	trAC = 60 ns	960	mA	3,4, 5,7
			trAC = 70 ns	800		
			trAC = 80 ns	720		
			trAC = 100 ns	640		
Operating current (Fast page mode)	I _{CC4}	$\overline{\text{RAS}} \leq V_{IL}(\text{MAX.}), \overline{\text{CAS}}$ Cycling $\text{tpc} = \text{tpc}(\text{MIN.})$ $I_o = 0 \text{ mA}$	trAC = 60 ns	720	mA	3,4,6
			trAC = 70 ns	640		
			trAC = 80 ns	560		
			trAC = 100 ns	480		
$\overline{\text{CAS}}$ before $\overline{\text{RAS}}$ refresh current	I _{CC5}	$\overline{\text{RAS}}$ Cycling $\text{trc} = \text{trc}(\text{MIN.})$ $I_o = 0 \text{ mA}$	trAC = 60 ns	960	mA	3,4
			trAC = 70 ns	800		
			trAC = 80 ns	720		
			trAC = 100 ns	640		
Input leakage current	I _{I(L)}	$V_i = 0 \text{ to } 5.5 \text{ V}$ all other pins not under test = 0 V	-10	+10	μA	
Output leakage current	I _{O(L)}	$V_o = 0 \text{ to } 5.5 \text{ V}$ Output is disabled (Hi-Z)	-10	+10	μA	
High level output voltage	V _{OH}	$I_o = -5.0 \text{ mA}$	2.4		V	
Low level output voltage	V _{OL}	$I_o = +4.2 \text{ mA}$		0.4	V	

[MC-421000A36 series]

Parameter	Symbol	Test condition	MIN.	MAX.	Unit	Notes
Operating current	I _{CC1}	$\overline{\text{RAS}}, \overline{\text{CAS}}$ Cycling $\text{trc} = \text{trc}(\text{MIN.})$ $\text{I}_o = 0 \text{ mA}$	trac = 60 ns	1 240	mA	3,4,7
			trac = 70 ns	1 120		
			trac = 80 ns	1 000		
			trac = 100 ns	880		
Standby current	I _{CC2}	$\overline{\text{RAS}}, \overline{\text{CAS}} \geq V_{\text{IH}}(\text{MIN.})$ $\text{I}_o = 0 \text{ mA}$		24	mA	
		$\overline{\text{RAS}}, \overline{\text{CAS}} \geq V_{\text{CC}} - 0.2 \text{ V}$ $\text{I}_o = 0 \text{ mA}$		12		
$\overline{\text{RAS}}$ only refresh current	I _{CC3}	$\overline{\text{RAS}}$ Cycling $\overline{\text{CAS}} \geq V_{\text{IH}}(\text{MIN.})$ $\text{trc} = \text{trc}(\text{MIN.})$ $\text{I}_o = 0 \text{ mA}$	trac = 60 ns	1 240	mA	3,4, 5,7
			trac = 70 ns	1 120		
			trac = 80 ns	1 000		
			trac = 100 ns	880		
Operating current (Fast page mode)	I _{CC4}	$\overline{\text{RAS}} \leq V_{\text{IL}}(\text{MAX.}), \overline{\text{CAS}}$ Cycling $\text{tpc} = \text{tpc}(\text{MIN.})$ $\text{I}_o = 0 \text{ mA}$	trac = 60 ns	1 040	mA	3,4,6
			trac = 70 ns	920		
			trac = 80 ns	800		
			trac = 100 ns	680		
$\overline{\text{CAS}}$ before $\overline{\text{RAS}}$ refresh current	I _{CC5}	$\overline{\text{RAS}}$ Cycling $\text{trc} = \text{trc}(\text{MIN.})$ $\text{I}_o = 0 \text{ mA}$	trac = 60 ns	1 240	mA	3,4
			trac = 70 ns	1 120		
			trac = 80 ns	1 000		
			trac = 100 ns	880		
Input leakage current	I _{I(L)}	V _I = 0 to 5.5 V all other pins not under test = 0 V	-10	+10	μA	
Output leakage current	I _{O(L)}	V _O = 0 to 5.5 V Output is disabled (Hi-Z)	-10	+10	μA	
High level output voltage	V _{OH}	I _o = -5.0 mA	2.4		V	
Low level output voltage	V _{OL}	I _o = +4.2 mA		0.4	V	

AC Characteristics (Recommended Operating Conditions unless otherwise noted) Notes 8, 9

Parameter	Symbol	t _{RAC} = 60 ns		t _{RAC} = 70 ns		t _{RAC} = 80 ns		t _{RAC} = 100 ns		Unit	Notes	
		MIN.	MAX.	MIN.	MAX.	MIN.	MAX.	MIN.	MAX.			
Read/Write Cycle Time	t _{RC}	120		140		160		190		ns		
Fast Page Mode Cycle Time	t _{PC}	40		45		50		60		ns		
Access Time from $\overline{\text{RAS}}$	t _{RAC}		60		70		80		100	ns	10,11	
Access Time from $\overline{\text{CAS}}$	MC-421000A32 MC-421000A36	t _{CAC}		15		20		20		25	ns	10,11
				20								
Access Time from Column Address	t _{AAC}		30		35		40		50	ns	10,11	
Access Time from $\overline{\text{CAS}}$ Precharge	t _{ACP}		35		40		45		55	ns	11	
$\overline{\text{RAS}}$ to Column Address Delay Time	t _{RAD}	15	30	15	35	17	40	17	50	ns	10	
$\overline{\text{CAS}}$ to Data Setup Time	t _{CLZ}	0		0		0		0		ns	11	
Output Buffer Turn-off Delay Time from $\overline{\text{CAS}}$	t _{OFF}	0	15	0	15	0	20	0	25	ns	12	
Transition Time (Rise and Fall)	t _T	3	50	3	50	3	50	3	50	ns		
$\overline{\text{RAS}}$ Precharge Time	t _{RP}	50		60		70		80		ns		
$\overline{\text{RAS}}$ Pulse Width	t _{RAS}	60	10 000	70	10 000	80	10 000	100	10 000	ns		
$\overline{\text{RAS}}$ Pulse Width (Fast Page Mode)	t _{RASP}	60	125 000	70	125 000	80	125 000	100	125 000	ns		
$\overline{\text{RAS}}$ Hold Time	t _{RSH}	20		20		20		25		ns		
$\overline{\text{CAS}}$ Pulse Width	t _{CAS}	20	10 000	20	10 000	20	10 000	25	10 000	ns		
$\overline{\text{CAS}}$ Hold Time	t _{CSH}	60		70		80		100		ns		
$\overline{\text{RAS}}$ to $\overline{\text{CAS}}$ Delay Time	t _{RCD}	20	40	20	50	25	60	25	75	ns	10	
$\overline{\text{CAS}}$ to $\overline{\text{RAS}}$ Precharge Time	t _{CRP}	10		10		10		10		ns	13	
$\overline{\text{CAS}}$ Precharge Time	t _{CPN}	10		10		10		10		ns		
$\overline{\text{CAS}}$ Precharge Time (Fast Page Mode)	t _{CP}	10		10		10		10		ns		
$\overline{\text{RAS}}$ Precharge $\overline{\text{CAS}}$ Hold Time	t _{RPC}	10		10		10		10		ns		
$\overline{\text{RAS}}$ Hold Time from $\overline{\text{CAS}}$ Precharge	t _{RHCP}	35		40		45		55		ns		
Row Address Setup Time	t _{ASR}	0		0		0		0		ns		
Row Address Hold Time	t _{RAH}	10		10		12		12		ns		
Column Address Setup Time	t _{ASC}	0		0		0		0		ns		
Column Address Hold Time	MC-421000A32 MC-421000A36	t _{CAH}		15		15		15		20	ns	
				17		20						
Column Address Lead Time Referenced to $\overline{\text{RAS}}$	t _{RAL}	30		35		40		50		ns		
Read Command Setup Time	t _{RCS}	0		0		0		0		ns		
Read Command Hold Time Referenced to $\overline{\text{RAS}}$	t _{RRH}	10		10		10		10		ns	14	
Read Command Hold Time Referenced to $\overline{\text{CAS}}$	t _{RCH}	0		0		0		0		ns	14	
$\overline{\text{WE}}$ Hold Time Referenced to $\overline{\text{CAS}}$	t _{WCH}	15		15		15		20		ns	15	
Data-in Setup Time	t _{DS}	0		0		0		0		ns	16	
Data-in Hold Time	MC-421000A32 MC-421000A36	t _{DH}		15		15		15		20	ns	16
						20						
Write Command Setup Time	t _{WCS}	0		0		0		0		ns	17	
$\overline{\text{CAS}}$ Setup Time ($\overline{\text{CAS}}$ before $\overline{\text{RAS}}$ Refresh)	t _{CSR}	10		10		10		10		ns		
$\overline{\text{CAS}}$ Hold Time ($\overline{\text{CAS}}$ before $\overline{\text{RAS}}$ Refresh)	t _{CHR}	15		15		15		20		ns		
$\overline{\text{WE}}$ Setup Time	t _{WSR}	10		10		10		10		ns		
$\overline{\text{WE}}$ Hold Time	t _{WHR}	15		15		15		20		ns		
Refresh Time	t _{REF}		16		16		16		16	ms		

Notes

1. All voltages are referenced to GND.
2. After power up, wait more than 100 μ s and then, execute eight $\overline{\text{CAS}}$ before $\overline{\text{RAS}}$ or $\overline{\text{RAS}}$ only refresh cycles as dummy cycles to initialize internal circuit.
3. I_{CC1} , I_{CC3} , I_{CC4} and I_{CC5} depend on cycles rates (t_{AC} and t_{EC}).
4. Specified values are obtained with outputs unloaded.
5. I_{CC3} is measured assuming that all column address inputs are held at either high or low.
6. I_{CC4} is measured assuming that all column address inputs are switched only once during each fast page cycle.
7. I_{CC1} and I_{CC3} are measured assuming that address can be changed once or less during $\overline{\text{RAS}} \leq V_{IH (MAX.)}$ and $\overline{\text{CAS}} \geq V_{IH (MIN.)}$.
8. AC measurements assume $t_T = 5$ ns.
9. AC Characteristics test condition

(1) Input timing specification

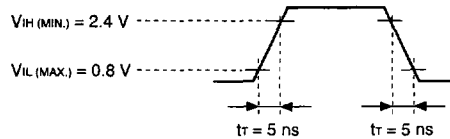

(2) Output timing specification

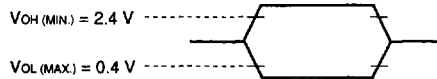

10. For read cycles, access time is defined as follows :

Input Conditions	Access Time	Access Time from $\overline{\text{RAS}}$
$t_{RAD} \leq t_{RAD (MAX.)}$ and $t_{RCD} \leq t_{RCD (MAX.)}$	$t_{RAC (MAX.)}$	$t_{RAC (MAX.)}$
$t_{RAD} > t_{RAD (MAX.)}$ and $t_{RCD} \leq t_{RCD (MAX.)}$	$t_{AA (MAX.)}$	$t_{RAD} + t_{AA (MAX.)}$
$t_{RCD} > t_{RCD (MAX.)}$	$t_{CAC (MAX.)}$	$t_{RCD} + t_{CAC (MAX.)}$

$t_{RAD (MAX.)}$ and $t_{RCD (MAX.)}$ are specified as reference points only ; they are not restrictive operating parameters. They are used to determine which access time (t_{RAC} , t_{AA} or t_{CAC}) is to be used for finding out when output data will be available. Therefore, the input conditions $t_{RAD} \leq t_{RAD (MAX.)}$ and $t_{RCD} \leq t_{RCD (MAX.)}$ will not cause any operation problems.

11. Loading conditions are 2 TTLs and 100 pF.
12. $t_{OFF (MAX.)}$ defines the time at which the output achieves the condition of Hi-Z and are not referenced to V_{OH} or V_{OL} .
13. $t_{CRP (MIN.)}$ requirement should be applied to $\overline{\text{RAS}}$, $\overline{\text{CAS}}$ cycles preceded by any cycles.
14. Either $t_{RCH (MIN.)}$ or $t_{RRH (MIN.)}$ should be met in read cycles.
15. In early write cycles, $t_{WCH (MIN.)}$ should be met.
16. $t_{DS (MIN.)}$ and $t_{DH (MIN.)}$ are referenced to the $\overline{\text{CAS}}$ falling edge in early write cycles.
17. If $t_{WCS} \geq t_{WCS (MIN.)}$, the cycle is an early write cycle and the data out will remain Hi-Z through the entire cycle.

CAS Before RAS Refresh Cycle

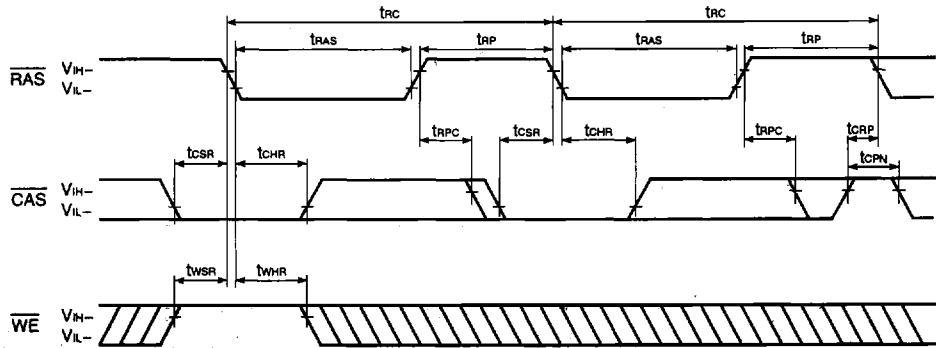

Remark Address = Don't care I/O = Hi - Z

RAS Only Refresh Cycle

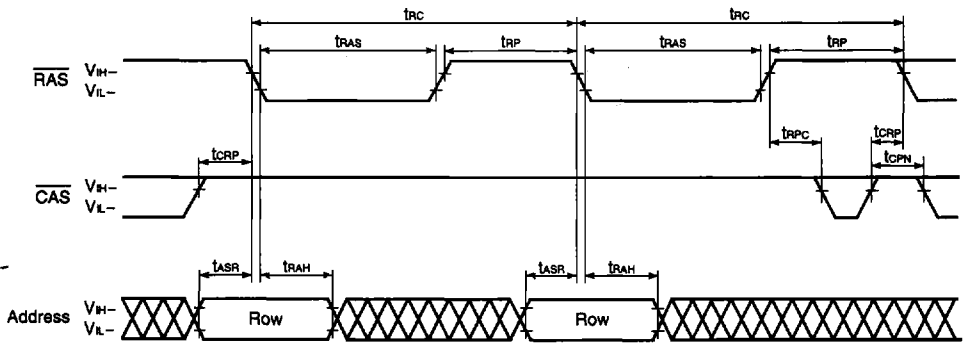

Remark WE = Don't care I/O = Hi - Z

Hidden Refresh Cycle

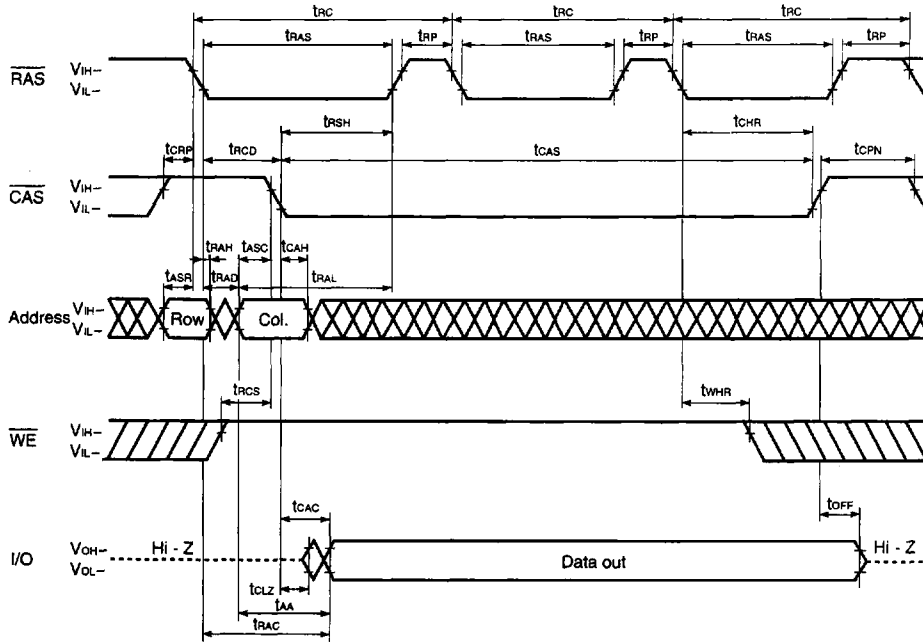

Package Drawings

MC-421000A32B, 421000A32F

72 PIN SINGLE IN-LINE MODULE (SOCKET TYPE)

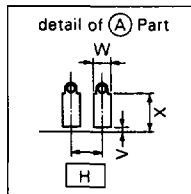
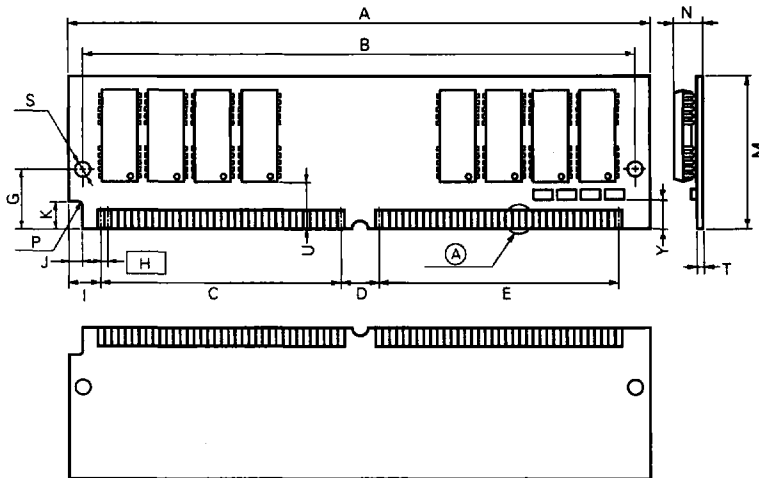

M72B-50A21-1

ITEM	MILLIMETERS	INCHES
A	107.95±0.13	4.250±0.006
B	101.19	3.984
C	44.45	1.750
D	6.35	0.250
E	44.45	1.750
G	10.16	0.400
H	1.27 (T.P.)	0.050 (T.P.)
I	6.35	0.250
J	2.03	0.080
K	6.35	0.250
M	25.4	1.000
N	5.08 MAX.	0.200 MAX.
P	R 2.0	R 0.079
S	∅3.18	∅0.125
T	1.27 ^{+0.01} _{-0.00}	0.050±0.004
U	6.5 MIN.	0.255 MIN.
V	0.25 MAX.	0.010 MAX.
W	1.04±0.05	0.041±0.002
X	2.54 MIN.	0.100 MIN.
Y	3.75 MIN.	0.147 MIN.

MC-421000A36BE, 421000A36FE
72 PIN SINGLE IN-LINE MODULE (SOCKET TYPE)

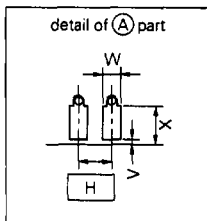
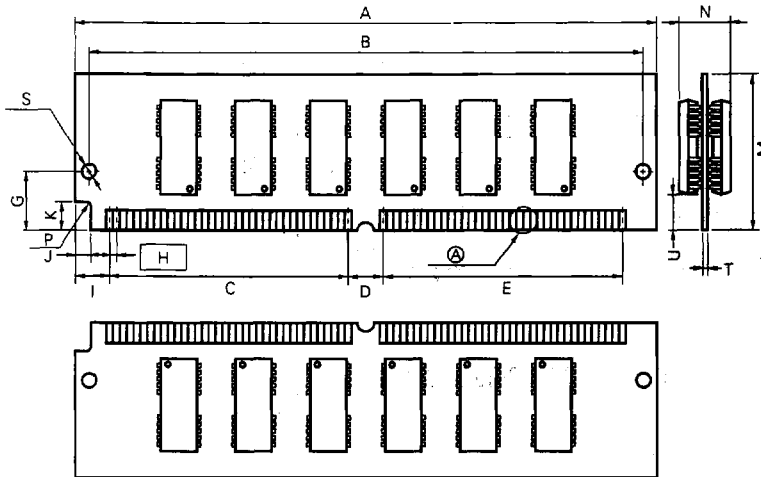

M72B-50A33-1

ITEM	MILLIMETERS	INCHES
A	107.95±0.13	4.250±0.006
B	101.19	3.984
C	44.45	1.750
D	6.35	0.250
E	44.45	1.750
G	10.16	0.400
H	1.27 (T.P.)	0.050 (T.P.)
I	6.35	0.250
J	2.03	0.080
K	6.35	0.250
M	25.4	1.000
N	9.0 MAX.	0.355 MAX.
P	R 1.57	R 0.062
S	∅3.18	∅0.125
T	1.27 ^{+0.1} _{-0.06}	0.050±0.004
U	6.0 MIN.	0.236 MIN.
V	0.25 MAX.	0.010 MAX.
W	1.04±0.05	0.041±0.002
X	2.54 MIN.	0.100 MIN.

MC-421000A36BJ, 421000A36FJ

72 PIN SINGLE IN-LINE MODULE (SOCKET TYPE)

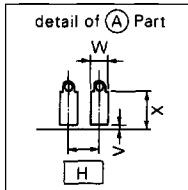
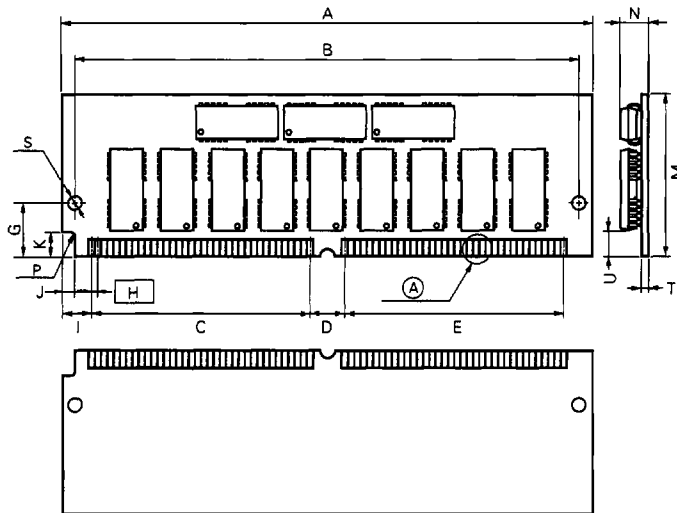

M72B-50A23-2

ITEM	MILLIMETERS	INCHES
A	107.95±0.13	4.250±0.006
B	101.19	3.984
C	44.45	1.750
D	6.35	0.250
E	44.45	1.750
G	10.16	0.400
H	1.27 (T.P.)	0.050 (T.P.)
I	6.35	0.250
J	2.03	0.080
K	6.35	0.250
M	31.75	1.250
N	5.08 MAX.	0.200 MAX.
P	R 2.0	R 0.079
S	∅3.18	∅0.125
T	1.27 ^{+0.1} _{-0.08}	0.050±0.004
U	3.78 MIN.	0.148 MIN.
V	0.25 MAX.	0.010 MAX.
W	1.04±0.05	0.041±0.002
X	2.54 MIN.	0.100 MIN.