

# HMXADC9225

## Radiation Hardened 12-Bit, 20 MSPS Monolithic A/D Converter

### Features

- Monolithic 12-Bit, 20 MSPS A/D Converter
- Rad Hard: 500k Rad(Si) Total Dose
- Single +5 V Analog Supply
- Complete On-Chip S/H Amplifier
- Straight Binary Output Data
- 5V or 3.3V Digital and I/O Supply
- No Missing Codes Guaranteed
- Differential Nonlinearity Error: 0.4 LSB
- Signal-to-Noise and Distortion Ratio: 69.6 dB
- Spurious-Free Dynamic Range: -71 dB
- 28-Lead Ceramic Flat Pack

### Mixed Signal Rad Hard Process

The HMXADC9225 is fabricated on space qualified SOI CMOS process. High-speed precision analog circuits are now combined with high-density logic circuits that can reliably withstand the harshest environments.

### Space Qualified Package

The HMXADC9225 is packaged in a 28 lead ceramic flat pack.

### Low Power

The HMXADC9225 at 335 mW consumes a fraction of the power of presently available in existing monolithic solutions.

### Output Enable (OE)

The OE input allows user to put the three-state digital outputs into a high impedance mode.

### Dual Power Supply Capability

The HMXADC9225 uses a single +5 V power supply simplifying system power supply design. It also features a separate digital I/O power supply line to accommodate 3.3V and 5V logic families.

### On-Chip Sample-and-Hold (SHA)

The versatile SHA input can be configured for either single-ended or differential inputs.

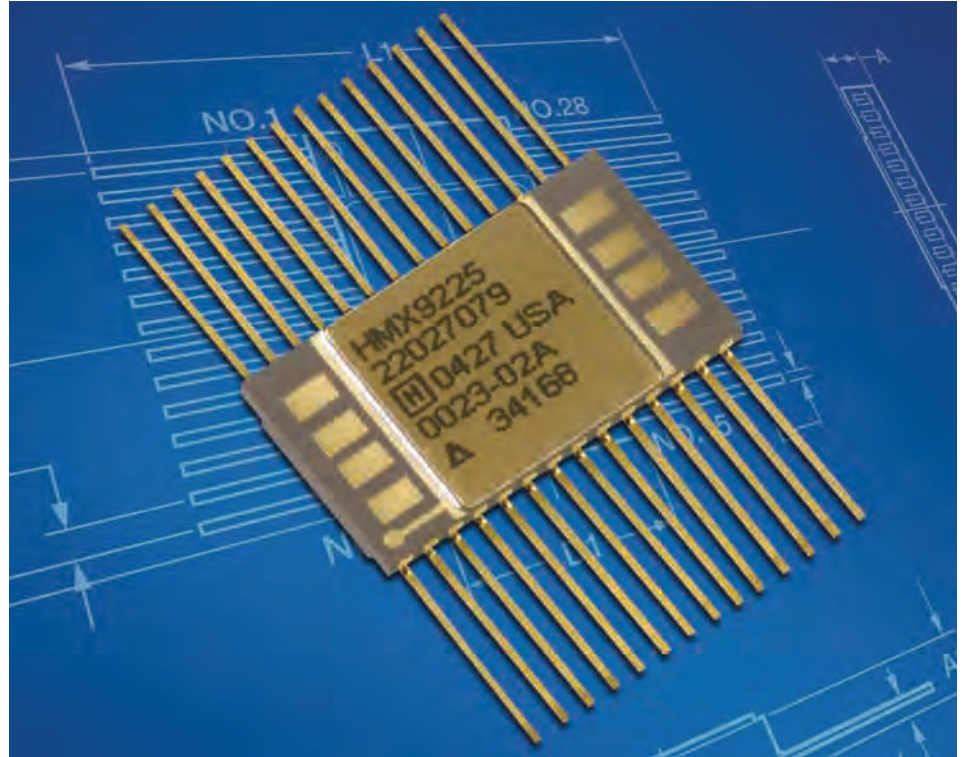

The HMXADC9225 is a radiation hardened monolithic, 12-bit, 20 MSPS, analog-to-digital converter with an on-chip, high performance sample-and-hold amplifier. The HMXADC9225 uses a multistage differential pipelined architecture with output error correction logic to provide 12-bit resolution at 20 MSPS data rates, and guarantees no missing codes over the full operating temperature range.

The HMXADC9225 is fabricated on a radiation hardened SOI-IV Silicon On Insulator (SOI) process with very low power consumption.

The input of the HMXADC9225 allows for easy interfacing to space and military imaging, sensor, and communications systems. With a truly differential input structure, the user can select a variety of input ranges and offsets including single-ended applications. The dynamic performance is excellent.

The sample-and-hold amplifier (SHA) is well suited for both multiplexed systems that switch full-scale voltage levels in successive channels and sampling single-channel inputs at frequencies up to and well beyond the Nyquist rate.

A single clock input is used to control all internal conversion cycles. The digital output data is presented in straight binary output format.



## Signal Definition

### DRVDD

The Digital Output Power Supply (DRVDD) can operate at either 5.0V or 3.3V. The DRVDD voltage defines the interface voltage level for all the digital I/O signals including Clock input, Output Enable, and all data output signals.

### Output Enable (OE)

This signal controls the electrical state of the digital output drivers. A high logic level will enable the outputs and a low logic level will put the output drivers into a high impedance state.

### RBIAS

R-Bias is required to create the internal bias currents. An external resistor with a value of 5kΩ shall be connected between pin 17 and ground.

### Voltage Reference Input

The HMXADC9225 requires the user to provide an external voltage reference as an INPUT to the device. The device is designed to operate using a 1.0V to 2.0V external voltage reference at the VREF pin. Due to the current on the VREF signal path, there should not be a series resistor between the voltage reference source and the the VREF pin. See Typical VREF Current chart below.

The input range will then be defined by the VREF. The full scale signal input = 2 x VREF. Signals outside this range will be considered “out of range”.

### Typical VREF Current

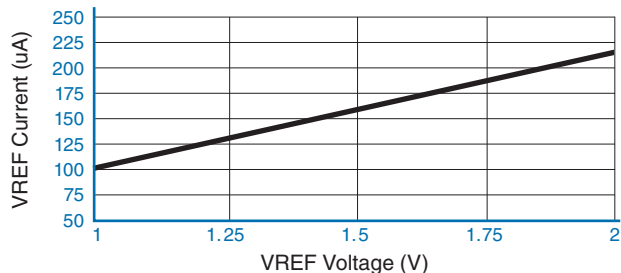

### Analog Sampling Timing Diagram

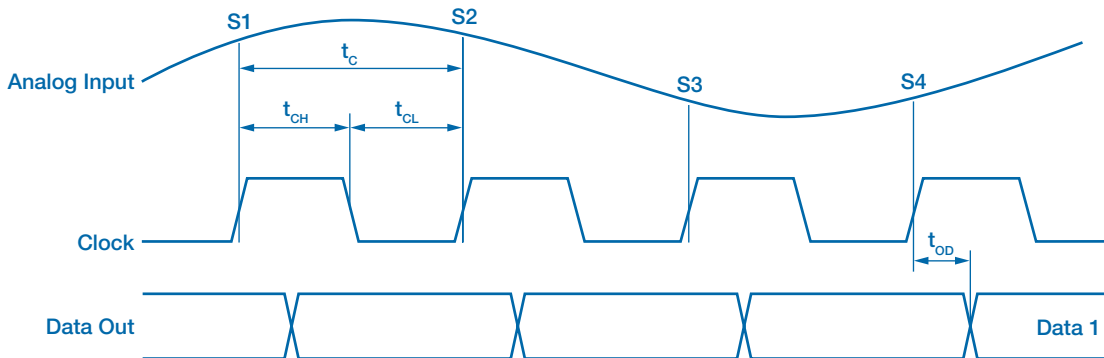

### CML (Common Mode Level)

This signal is an analog output at a value of AVDD/2. It can be used as a reference for biasing external circuits to a “mid-rail” value. This signal should be decoupled with a 0.1µF capacitor.

### RADIATION CHARACTERISTICS

#### Total Ionizing Radiation Dose

The HMXADC9225 has a radiation hardness assurance TID level of 500k rad(Si), including overdose and accelerated annealing per MIL-STD-883 Method 1019. Total dose hardness is assured by qualification testing with a Co60 source and wafer level X-ray testing during manufacturing.

#### Soft Error Rate

In a particle radiation environment, output code errors may occasionally occur. These are temporary and normal operation will resume on subsequent clock cycles. With the pipeline architecture, it may take up to 4 clock cycles to clear the pipeline.

#### Transient Pulse Ionizing Radiation

The HMXADC9225 will meet functional and electrical specifications after exposure to a transient dose rate survivability radiation pulse up to the listed specification. The part is not guaranteed to operate through a dose rate event, but it will recover and continue to meet all specifications after an event.

#### Latchup

The device will not latch up due to any of the above radiation exposure conditions when applied under recommended operating conditions. Fabrication with the SOI CMOS substrate material provides oxide isolation between adjacent PMOS and NMOS transistors and eliminates any potential SCR latchup structures.

#### Neutron Radiation

SOI CMOS is inherently tolerant of neutron radiation. The HMXADC9225 meets functional and timing specifications after exposure to the specified neutron fluence, based on conventional neutron irradiation testing, on unpowered HMXADC9225 parts.

## Output Enable Timing Diagram

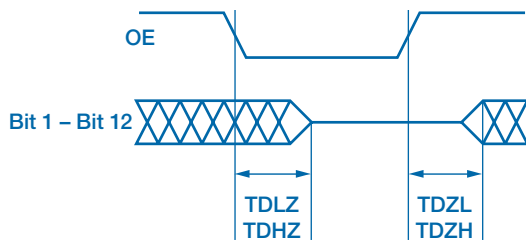

## Switching Specifications

(AVDD = +5V, DRVDD = +5V)

Parameter	Symbol	Min	Typ	Max	Units
Clock Period (1)	$t_c$	50			ns
Clock Pulsewidth High (46% of $t_c$ ) (1)	$t_{cH}$	23			ns
Clock Pulsewidth Low (46% of $t_c$ ) (1)	$t_{cL}$	23			ns
Output Delay	$t_{od}$	3		25	ns
High Z to Output High (DRVDD=5V) (2)	TDZH_50			25	ns
High Z to Output Low (DRVDD=5V) (2)	TDZL_50			25	ns
Output High to High Z (DRVDD=5V) (2)	TDHZ_50			25	ns
Output Low to High Z (DRVDD=5V) (2)	TDLZ_50			25	ns
High Z to Output High (DRVDD=3.3V) (2)	TDZH_33			25	ns
High Z to Output Low (DRVDD=3.3V) (2)	TDZL_33			25	ns
Output High to High Z (DRVDD=3.3V) (2)	TDHZ_33			25	ns
Output Low to High Z (DRVDD=3.3V) (2)	TDLZ_33			25	ns

(1) These are parameters of the input clock signal to the chip.

(2) Refer to "Output Enable Timing Diagram" for waveform.

## Radiation Specifications

Parameter	Limit	Units
Total Dose Hardness	$5 \times 10^5$	rad(Si)
Single Event Latchup (1)	120	MeV-cm <sup>2</sup> /mg
Soft Error Rate	See note (2)	
Dose Rate Survivability	$1 \times 10^{12}$	rad(Si)/s
Neutron (3)	$1 \times 10^{13}$	N/cm <sup>2</sup>

(1) The SOI CMOS technology is immune to latchup.

(2) In a particle radiation environment, output code errors may occasionally occur. These are temporary and normal operation will resume on subsequent clock cycles.

(3) 1MeV equivalent energy, Unbiased.

## Absolute Maximum Ratings

(AVDD = +5V, DRVDD = +5V, unless otherwise noted)

Parameters	Min	Max	Units
AVDD	-0.5	6.5	Volts
DRVDD	-0.5	6.5	Volts
AVSS	-0.5		Volts
DRVSS	-0.5		Volts
REFGND	-0.5		Volts
CLK, OE	-0.5	6.5	Volts
Bit 1 – Bit 12	-0.5	6.5	Volts
VINA, VINB	-0.5	6.5	Volts
VREF	-0.5	6.5	Volts
REFT, REFB		6.5	Volts
Package Thermal Resistance ( $\theta_{JC}$ )		2.0	°C/W
Junction Temperature		+175	°C

## Recommended Operating Conditions

Specifications listed in datasheet apply when used under the Recommended Operating Conditions unless otherwise specified.

Parameters	Min	Typ	Max	Units
AVDD	4.75	5	5.25	Volts
DRVDD (for 5V I/O operation)	4.75	5	5.25	Volts
DRVDD (for 3.3V I/O operation)	3.0	3.3	3.6	Volts
AVSS	-0.3	0		Volts
DRVSS	-0.3	0		Volts
REFGND	-0.3	0		Volts
CLK, OE	-0.3		DRVDD + 0.5	Volts
Bit 1 – Bit 12	-0.3		5.5	Volts
VINA, VINB	0.5		4.5	Volts
VREF	1.0		2.0	Volts
REFT, REFB			5.5	Volts
Operating Temperature (case)	-55		+125	°C

## ESD (Electrostatic Discharge) Sensitive

The HMXADC9225 is rated as Class 1B ESD, Human Body Model. Proper ESD precautions should be taken to avoid degradation or damage to the device.

## DC Specifications

(AVDD = +5V, DRVDD = +5V,  $f_{\text{SAMPLE}} = 20$  MSPS, VREF 2.0V, VINB = 2.5V dc, unless otherwise noted)

Parameter	Symbol	Min	Typ	Max	Units
<b>Resolution (1)</b>		12			Bits
<b>Max Conversion Rate (1)</b>				20	MHz
<b>Input Referred Noise</b>					
VREF = 2V (1)			0.17		LSB rms
<b>Accuracy</b>					
Integral Nonlinearity	INL	-2.5	±1.2	2.5	LSB
Differential Nonlinearity	DNL	-1.0	±0.4	1.0	LSB
No Missing Codes (1)			12		Bits guaranteed
Zero Error (@ 25°C)	OFFSET	-0.9	±0.3	0.9	% FSR
Gain Error (@ 25°C)	GAIN	-2	±0.5	2	% FSR
<b>Temperature Drift</b>					
Zero Error (@ 25°C) (1)			+/- 2		PPM/°C
Gain Error (@ 25°C) (1)			+/- 26		PPM/°C
<b>Analog Input</b>					
Input Span			4		V p-p
Input Capacitance (1)			10		pF
<b>External Voltage Reference</b>					
Input Voltage (2)		1.0	2.0	2.0	V
Input Current			250	500	µA
<b>Power Supply Currents</b>					
IAVDD				65	mA
IDRVDD				2	mA
<b>CML Output Current (3)(1)</b>			0.5	1.0	mA
<b>RBIAS Resistor Value</b>			5		KΩ

(1) Guaranteed but not tested.

(2) Recommended VREF tolerance is +/- 10 mV.

(3) It is recommended an external buffer be used for driving external circuitry.

## AC Specifications

(AVDD = +5V, DRVDD = +5V,  $f_{\text{SAMPLE}} = 20$  MSPS, VREF 2.0V, Differential Input unless otherwise noted)

Parameter	Symbol	Min	Typ	Max	Units
Signal to Noise and Distortion $f_{\text{IN}} = 1$ MHz	SINAD1	63	67	-	dB
Signal to Noise and Distortion $f_{\text{IN}} = 5$ MHz	SINAD5	60	66	-	dB
Signal to Noise Ratio $f_{\text{IN}} = 1$ MHz	SNR1	63	69	-	dB
Signal to Noise Ratio $f_{\text{IN}} = 5$ MHz	SNR5	60	68	-	dB
Total Harmonic Distortion $f_{\text{IN}} = 1$ MHz	THD1	-	-70	-66	dB
Total Harmonic Distortion $f_{\text{IN}} = 5$ MHz	THD5	-	-69	-66	dB
Spurious Free Dynamic Range $f_{\text{IN}} = 1$ MHz	SFDR1	70	72	-	dB
Spurious Free Dynamic Range $f_{\text{IN}} = 5$ MHz	SFDR5	68	71	-	dB
Full Power Bandwidth (1)			120		MHz
Small Signal Bandwidth (1)			120		MHz
Aperture Delay (1)			1		ns
Aperture Jitter (1)			4		ps rms
Acquisition to Full Scale Step (1)			10		ns

(1) Guaranteed but not tested.

## Digital Specifications

(AVDD = +5V, DRVDD = +5V, unless otherwise noted)

Parameter	Symbol	Min	Typ	Max	Units
<b>Logic Inputs (CLK, OE)</b>					
High Level Input Voltage (DRVDD = +5V)	VIH_50	3.5			V
High Level Input Voltage (DRVDD = +3.3V)	VIH_33	2.3			V
Low Level Input Voltage (DRVDD = +5V)	VIL_50			1.0	V
Low Level Input Voltage (DRVDD = +3.3V)	VIL_33			1.0	V
High Level Input Current (DRVDD=5V, VIN=5V)	IIH_50	-10		10	μA
Low Level Input Current (DRVDD=5V, VIN=0V)	IIL_50	-10		10	μA
High Level Input Current (DRVDD=3.3V, VIN=3.3V)	IIH_33	-10		10	μA
Low Level Input Current (DRVDD=3.3V, VIN=0V)	IIL_33	-10		10	μA
Input Capacitance (1)	C <sub>IN</sub>		5		pF
<b>Logic Outputs (D1-D12 with DRVDD = +5V)</b>					
High Level Output Voltage(I <sub>OH</sub> = -50μA)	VOH1_50	4.5			V
High Level Output Voltage(I <sub>OH</sub> = -0.5mA)	VOH2_50	2.4			V
Low Level Output Voltage(I <sub>OL</sub> = 1.6mA)	VOL2_50			0.4	V
Low Level Output Voltage(I <sub>OL</sub> = 50μA)	VOL1_50			0.1	V
High Z Output Current (DRVDD=5V, OE=0V, VOUT=5V)	IOZH_50	-10		10	μA
High Z Output Current (DRVDD=5V, OE=0V, VOUT=0V)	IOZL_50	-10		10	μA
<b>Logic Outputs (D1-D12 with DRVDD = +3.3V)</b>					
High Level Output Voltage(I <sub>OH</sub> = -50μA)	VOH1_33	2.95			V
High Level Output Voltage(I <sub>OH</sub> = -0.5mA)	VOH2_33	2.80			V
Low Level Output Voltage(I <sub>OL</sub> = 50μA)	VOL1_33			0.05	V
Low Level Output Voltage(I <sub>OL</sub> = 1.6mA)	VOL2_33			0.4	V
High Z Output Current (DRVDD=3.3V, VOE=0V, VOUT=3.3V)	IOZH_33	-10		10	μA
High Z Output Current (DRVDD=3.3V, VOE=0V, VOUT=0V)	IOZL_33	-10		10	μA
Output Capacitance (1)	C <sub>OUT</sub>		5		pF

(1) Guaranteed but not tested.

## Definitions of Specifications

### Integral Nonlinearity (INL)

INL refers to the deviation of each individual code from a line drawn from “negative full scale” through “positive full scale.” The point used as “negative full scale” occurs 1/2 LSB before the first code transition. “Positive full scale” is defined as a level 1 1/2 LSB beyond the last code transition. The deviation is measured from the middle of each particular code to the true straight line.

### Differential Nonlinearity (DNL, No Missing Codes)

An ideal ADC exhibits code transitions that are exactly 1 LSB apart. DNL is the deviation from this ideal value. Guaranteed no missing codes to 12-bit resolution indicate that all 4096 codes, respectively, must be present over all operating ranges.

### Zero Error

The major carry transition should occur for an analog value 1/2 LSB below V<sub>INA</sub> = V<sub>INB</sub>. Zero error is defined as the deviation of the actual transition from that point.

### Gain Error

The first code transition should occur at an analog value 1/2 LSB above negative full scale. The last transition should occur at an analog value 1 1/2 LSB below the nominal full scale.

Gain error is the deviation of the actual difference between first and last code transitions and the ideal difference between first and last code transitions.

### Temperature Drift

The temperature drift for zero error and gain error specifies the maximum change from the initial (+25°C) value to the value at -55°C or +125°C.

### Aperture Jitter

Aperture jitter is the variation in aperture delay for successive samples and is manifested as noise on the input to the A/D.

### Aperture Delay

Aperture delay is a measure of the sample-and-hold amplifier (SHA) performance and is measured from the rising edge of the clock input to when the input signal is held for conversion.

### Signal-to-Noise and Distortion (S/N+D, SINAD) Ratio

S/N+D is the ratio of the rms value of the measured input signal to the rms sum of all other spectral components below the Nyquist frequency, including harmonics but excluding dc. The value for S/N+D is expressed in decibels.

### Effective Number of Bits (ENOB)

For a sine wave, SINAD can be expressed in terms of the number of bits. Using the following formula,

$$N = (\text{SINAD} - 1.76)/6.02$$

it is possible to get a measure of performance expressed as N, the effective number of bits. Thus, effective number of bits for a device for sine wave inputs at a given input frequency can be calculated directly from its measured SINAD.

### Typical DNL (10MSPS)

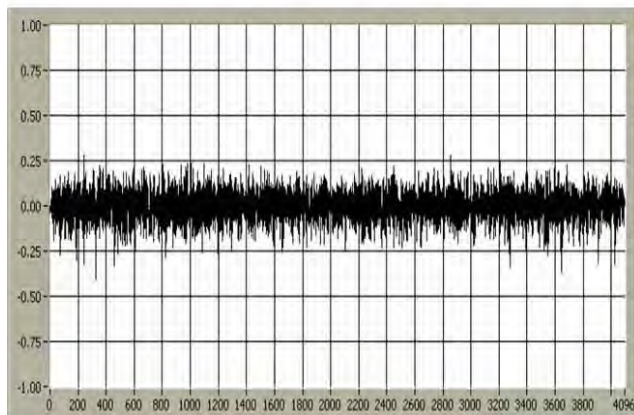

### Total Harmonic Distortion (THD)

THD is the ratio of the rms sum of the first six harmonic components to the rms value of the measured input signal and is expressed as a percentage or in decibels.

### Signal-to-Noise Ratio (SNR)

SNR is the ratio of the rms value of the measured input signal to the rms sum of all other spectral components below the Nyquist frequency, excluding the first six harmonics and dc. The value for SNR is expressed in decibels.

### Spurious Free Dynamic Range (SFDR)

SFDR is the difference in dB between the rms amplitude of the input signal and the peak spurious signal.

### Typical INL (10MSPS)

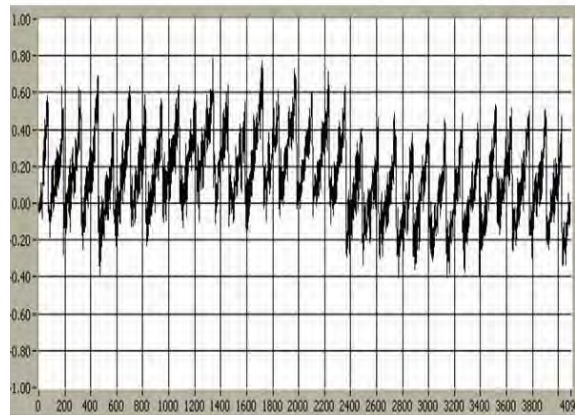

## Functional Description

The HMXADC9225 is a complete high performance single-supply 12-bit ADC. The analog input range of the HMXADC9225 is highly flexible allowing for either single-ended or differential inputs of varying amplitudes that can be AC or DC coupled.

It utilizes four-stage pipeline architecture with a wideband input sample-and-hold amplifier (SHA) implemented on an SOI CMOS process. Each stage of the pipeline, excluding the last stage, consists of a low-resolution flash A/D connected to a switched capacitor DAC and interstage residue amplifier (MDAC). The residue amplifier amplifies the difference between the reconstructed DAC output and the flash input for the next stage in the pipeline. One bit of redundancy is used in each of the stages to facilitate digital correction of flash errors. The last stage simply consists of a flash A/D.

The pipeline architecture allows a greater throughput rate at the expense of pipeline delay or latency. This means that while the converter is capable of capturing a new input sample every clock cycle, it actually takes three clock cycles for the conversion to be fully processed and appear at the output. This latency is not a concern in most applications. The digital output is latched into an output buffer to drive the output pins.

The HMXADC9225 uses both edges of the clock in its internal timing circuitry (see Timing Diagram and specification page for exact timing requirements). The A/D samples the analog input on the rising edge of the clock input. During the clock low time (between the falling edge and rising edge of the clock), the input SHA is in the sample mode; during the clock high time it is in hold. System disturbances just prior to the rising edge of the clock and/or excessive clock jitter may cause the input SHA to acquire the wrong value, and should be minimized.

## Analog Input Operation

Figure 1 shows the equivalent analog input of the HMXADC9225, which consists of a differential sample-and-hold amplifier (SHA). The differential input structure of the SHA is highly flexible, allowing the devices to be easily configured for either a differential or single-ended input. The dc offset, or common mode voltage, of the input(s) can be set to accommodate either single-supply or dual-supply systems. Also, note that the analog inputs, VINA and VINB, are interchangeable with the exception that reversing the inputs to the VINA and VINB pins results in a polarity inversion.

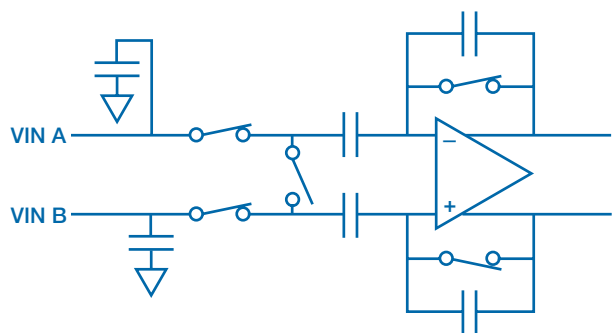

**Figure 1 – Analog Input Equivalent Circuit**  
The full scale signal input = 2 x VREF.

### Digital Outputs

The HMXADC9225 output data is presented in positive true straight binary for all input ranges. The table below indicates the output data formats for various input ranges regardless of the selected input range. A twos complement output data format can be created by inverting the MSB. The outputs can be placed in high impedance tri-state mode and are controlled by the Output Enable (OE) signal.

### Output Data Format

Input (V)	Condition (V)	Digital Output
VINA-VINB	< - VREF	0000 0000 0000
VINA-VINB	= - VREF	0000 0000 0000
VINA-VINB	= 0	1000 0000 0000
VINA-VINB	= + VREF - 1 LSB	1111 1111 1111
VINA-VINB	≥ + VREF	1111 1111 1111

### Digital Output Driver Considerations (DRVDD)

The HMX9225 output drivers shall be operated at 5.0 volts or at 3.3 volts. The output drivers are sized to provide sufficient output current to drive a wide variety of logic families. However, large drive currents tend to cause glitches on the supplies and may affect SINAD performance. Applications requiring the ADC to drive large capacitive loads or large fanout may require additional decoupling capacitors on DRVDD. In extreme cases, external buffers or latches may be required.

### Clock Input and Considerations

The HMX9225 internal timing uses the two edges of the clock input to generate a variety of internal timing signals. The clock input must meet or exceed the minimum specified pulse width high and low ( $t_{CH}$  and  $t_{CL}$ ) specifications for the given A/D as defined in the Switching Specifications at the beginning of the data sheet to meet the rated performance specifications.

For example, the clock input to the HMX9225 operating at 20 MSPS may have a duty cycle between 45% to 55% to meet this timing requirement since the minimum specified  $t_{CH}$  and  $t_{CL}$  is 23 ns. For low clock rates, the duty cycle may deviate from this range to the extent that both  $t_{CH}$  and  $t_{CL}$  are satisfied.

All high-speed high resolution A/Ds are sensitive to the quality of the clock input. The degradation in SNR at a given full-scale input frequency ( $f_{IN}$ ) due to only aperture jitter ( $t_A$ ) can be calculated with the following equation:

$$SNR = 20 \log_{10} \left[ \frac{1}{2p f_{IN} t_A} \right]$$

In the equation, the rms aperture jitter,  $t_A$ , represents the root sum square of all the jitter sources, which include the clock input, analog input signal, and A/D aperture jitter specification. Under sampling applications are particularly sensitive to jitter.

Clock input should be treated as an analog signal in cases where aperture jitter may affect the dynamic range of the HMXADC9225. Power supplies for clock drivers should be separated from the A/D output driver supplies to avoid modulating the clock signal with digital noise. Low jitter crystal controlled oscillators make the best clock sources. If the clock is generated from another type of source (by gating, dividing, or other method), it should be retimed by the original clock at the last step. The clock input is referred to the analog supply. Its logic threshold is AVDD/2.

The input circuitry for the CLOCK pin is designed to accommodate CMOS inputs. The quality of the logic input, particularly the rising edge, is critical in realizing the best possible jitter performance of the part: the faster the rising edge, the better the jitter performance.

As a result, careful selection of the logic family for the clock driver, as well as the fanout and capacitive load on the clock line, is important. Jitter-induced errors become more predominant at higher frequency, large amplitude inputs, where the input slew rate is greatest. Most of the power dissipated by the HMX9225 is from the analog power supplies. However, lower clock speeds will reduce digital current.

## Grounding and Decoupling

### Analog and Digital Grounding

Proper grounding is essential in any high speed, high-resolution system. Multilayer printed circuit boards (PCBs) are recommended to provide optimal grounding and power schemes. The use of ground and power planes offers distinct advantages:

1. The minimization of the loop area encompassed by a signal and its return path.
2. The minimization of the impedance associated with ground and power paths.
3. The inherent distributed capacitor formed by the power plane, PCB insulation and ground plane.

These characteristics result in both a reduction of electromagnetic interference (EMI) and an overall improvement in performance.

It is important to design a layout that prevents noise from coupling onto the input signal. Digital signals should not be run in parallel with input signal traces and should be routed away from the input circuitry. While the HMXADC9225 features separate analog and driver ground pins, it should be treated as an analog component. The AVSS and DRVSS pins must be joined together directly under the HMXADC9225. A solid ground plane under the A/D is acceptable if the power and ground return currents are carefully managed. Alternatively, the ground plane under the A/D may contain serrations to steer currents in predictable directions where cross coupling between analog and digital would otherwise be unavoidable.

### Analog and Digital Driver Supply Decoupling

The HMXADC9225 features separate analog and driver supply and ground pins, helping to minimize digital corruption of sensitive analog signals.

In general, AVDD, the analog supply, should be decoupled to AVSS, the analog common, as close to the chip as physically possible.

It is recommended to use 0.1 uF ceramic chip and 10 uF tantalum capacitors for the AVDD and DRVDD power inputs. A 0.1 uF ceramic chip capacitor is adequate on the CML pin.

## Reliability

For many years Honeywell has been producing integrated circuits that meet the stringent reliability requirements of space and defense systems. Honeywell has delivered hundreds of thousands of QML parts since first becoming QML qualified in 1990. Using this proven approach Honeywell will assure the reliability of the products manufactured with the SOI CMOS process technology. This approach includes adhering to Honeywell's Quality Management Plan for:

- Designing in reliability by establishing electrical rules based on wear out mechanism characterization performed on specially designed test structures (electromigration, TDDB, hot carriers, bias temperature instability, radiation)
- Utilizing a structured and controlled design process
- A statistically controlled wafer fabrication process with a continuous defect reduction process
- Individual wafer lot acceptance through process monitor testing (includes radiation testing)
- The use of characterized and qualified packages
- A thorough product testing program based on MIL-PRF-38535 and MIL-STD 883.

## Screening and Conformance Inspection

The product test flow includes screening units with the applicable flow (Engineering Model, Class V and Q equivalent) and the appropriate periodic or lot conformance testing (Groups A, B, C, D, and E). Both the wafer process and the products are subject to period or lot based Technology Conformance Inspection (TCI) and Quality Conformance Inspection (QCI) tests as defined by Honeywell's Quality Management Plan.

## Conformance Summary

Group A	General Electrical Tests
Group B	Mechanical – Resistance to Solvents, Bond Strength, Die Shear, Solderability
Group C	Life Tests – 1000 hours at 125°C or equivalent
Group D	Package Related Mechanical Tests – Physical Dimensions, Lead Integrity, Thermal Shock, Temp Cycle, Moisture Resistance, Seal, Mechanical Shock, Vibration, Acceleration, Salt Atmosphere, Internal Water Vapor, Adhesion of Lead Finish
Group E	Radiation Tests

## Package Definition

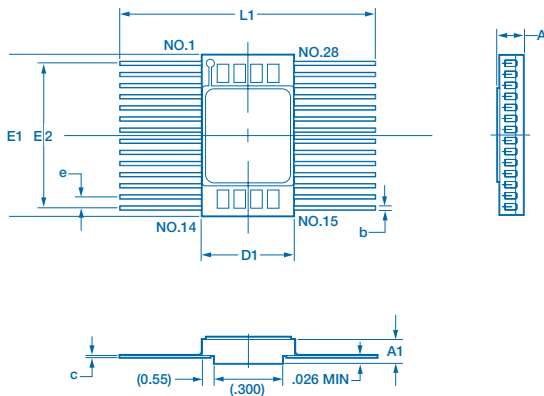

## Dimensions

Symbol	(Inches)	Min.	Norm	Max.
A		.108	.122	.133
A1		.098	.107	.117
b		.015	.017	.019
c		.004	.005	.006
D1		.404	.410	.416
E1		.712	.720	.728
E2		.645	.650	.655
e		.050 BSC		
L1		1.150 BSC		
N		28		

## Ordering Information

H	MX	ADC	9225	N	Z	G
<b>Source</b> H = Honeywell	<b>Process</b> M = Mixed Signal X = SOI	<b>Part Type</b>	<b>Part Number</b>	<b>Package Destination</b> N = 28 Pin Flat Pack	<b>Screen Level</b> Z = Class Level S\QML V Equivalent (1) Y = Class Level B\QML Q Equivalent (2) E = Eng. Model(3)	<b>Total Dose Hardness</b> G = $5 \times 10^5$ rad (Si) N = No Level Guaranteed (3)

(1) These receive the Class V screening and QCI is included.  
Customer must specify QCI requirements.

(2) These receive the Class Q screening but do not have QCI included.

(3) Engineering Model Description: Parameters are tested -55°C to 125°C,  
24 hour burn-in, no radiation guaranteed

To learn more about Honeywell's radiation hardened integrated circuit products and technologies, visit [www.honeywellmicroelectronics.com](http://www.honeywellmicroelectronics.com).

Honeywell reserves the right to make changes of any sort without notice to any and all products, technology and testing identified herein. You are advised to consult Honeywell or an authorized sales representative to verify that the information in this data sheet is current before ordering this product. Absent express contract terms to the contrary, Honeywell does not assume any liability of any sort arising out of the application or use of any product or circuit described herein; nor does it convey any license or other intellectual property rights of Honeywell or of third parties.

### Honeywell Aerospace

12001 Highway 55  
Plymouth, MN 55441

Tel: 800-323-8295

[www.honeywellmicroelectronics.com](http://www.honeywellmicroelectronics.com)

ADS-14131, Rev. E  
May 2014  
© 2014 Honeywell International Inc.

# Honeywell