

54F161A, 54F163A Counters

4-Bit Binary Counters

Product Specification

Military FAST Products

FEATURES

- Synchronous counting and loading
- Two Count Enable Inputs for n-bit cascading
- Positive edge-triggered clock
- Asynchronous reset (54F161A)
- Synchronous reset (54F163A)
- High-speed synchronous expansion
- Typical count rate of 120MHz

DESCRIPTION

Synchronous 4-bit (54F161A, 54F163A) counters feature an internal carry look-ahead and can be used for high-speed counting. Synchronous operation is provided by having all flip-flops clocked simultaneously on the positive-going edge of the clock. The Clock input is buffered.

ORDERING INFORMATION

DESCRIPTION	ORDER CODE
Ceramic DIP	54F161A/BEA 54F163A/BEA
Ceramic Flat Pack	54F161A/BFA 54F163A/BFA
20-Pin Ceramic LLCC	54F161A/B2A 54F163A/B2A

INPUT AND OUTPUT LOADING AND FAN-OUT TABLE

PINS	DESCRIPTION	54F(U.L.) HIGH/LOW	LOAD VALUE HIGH/LOW
CEP	Count enable parallel input	1.0/1.0	20 μ A/0.6mA
CET	Count enable trickle input	1.0/2.0	20 μ A/1.2mA
CP	Clock pulse input (active rising edge)	1.0/1.0	20 μ A/0.6mA
MR	Asynchronous master reset input (active Low)	1.0/1.0	20 μ A/0.6mA
SR	Synchronous reset input (active Low)	1.0/2.0	20 μ A/1.2mA
D ₀ - D ₃	Parallel data inputs	1.0/1.0	20 μ A/0.6mA
PE	Parallel enable input (active Low)	1.0/2.0	20 μ A/1.2mA
Q ₀ - Q ₃	Flip-flop outputs	50/33	1.0mA/20mA
tC	Terminal count output	50/33	1.0mA/20mA

NOTE: One (1.0) FAST Unit Load (U.L.) is defined as: 20 μ A in the High state and 0.6mA in the Low state.

PIN CONFIGURATION

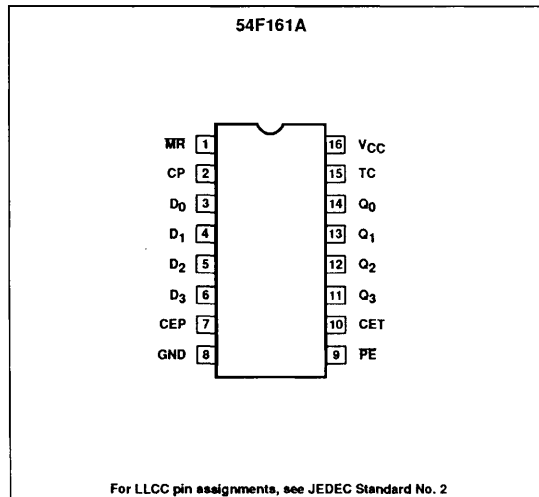

LOGIC SYMBOL

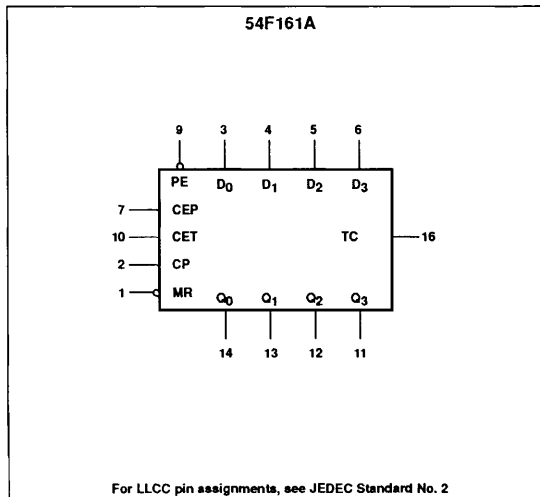

Counters

54F161A, 54F163A

PIN CONFIGURATION

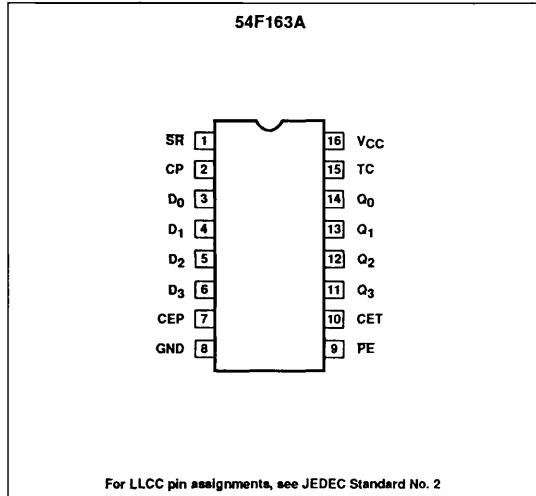

LOGIC SYMBOL

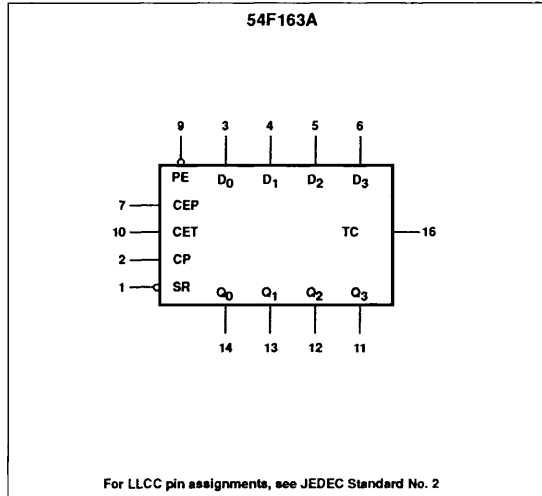

STATE DIAGRAM

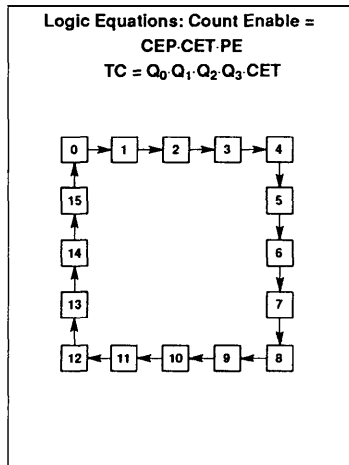

causes the data at the D₀ - D₃ inputs to be loaded into the counter on the positive-going edge of the clock (providing that the setup and hold requirements for PE are met). Preset takes place regardless of the levels at Count Enable (CEP, CET) inputs.

A Low level at the Master Reset (\overline{MR}) input sets all four outputs of the flip-flops (Q₀ - Q₃) in 54F161A to Low levels, regardless of the levels at CP, PE, CET and CEP inputs (thus providing an asynchronous clear function).

For the 54F163A, the clear function is synchronous. A Low level at the Reset (SR) input sets all four outputs of the flip-flops (Q₀ - Q₃) to Low levels after the next positive-going transition on the Clock (CP) input (providing that the setup and hold requirements for MR are met). This action occurs regardless of the levels at PE, CET, and CEP inputs. This synchronous reset feature enables the designer to modify the maximum count with only one external NAND gate (see Figure A).

The carry look-ahead simplifies serial cascading of the counters. Both Count Enable inputs (CEP and CET) must be High to count. The

CET input is fed forward to enable the TC output. The TC output thus enabled will produce a High output pulse of a duration approximately equal to the High level output of Q₀. This pulse can be used to enable the next cascaded stage (see Figure B).

For conventional operation of 54F161A and 54F163A, the following transitions should be avoided:

1. High-to-Low transition on the CEP or CET input if Clock is Low.
2. Low-to-High transition on the Parallel Enable input when CP is Low, if the count enables and MR are High at or before the transition.

For 54F163A there is an additional transition to be avoided:

3. Low-to-high transition on the \overline{MR} input when Clock is Low, if the Enable and PE inputs are High at or before the transition. The TC output is subject to decoding spikes due to internal race conditions. Therefore, it is not recommended for use as clock or asynchronous reset for flip-flops, registers, or counters.

Counters

54F161A, 54F163A

LOGIC DIAGRAM

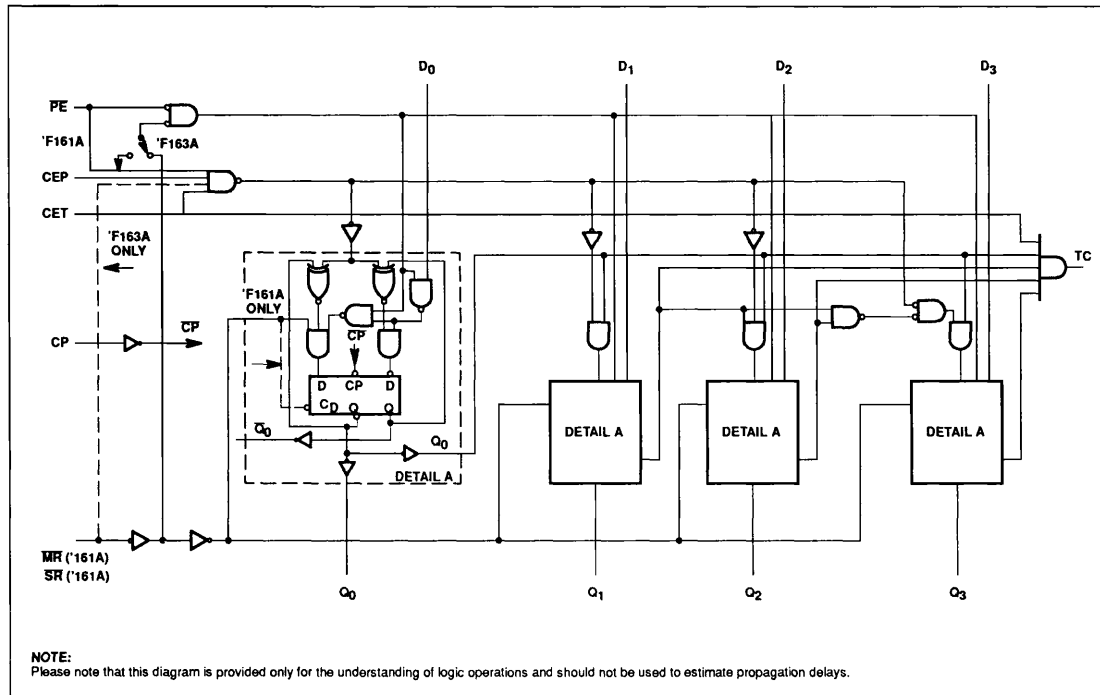

MODE SELECT — FUNCTION TABLE, 54F161A

OPERATING MODE	INPUTS						OUTPUTS	
	MR	CP	CET	CET	PE	D _n	Q _n	TC
Reset (clear)	L	X	X	X	X	X	L	L
Parallel load	H	↑	X	X	l	l	L	L
	H	↑	X	X	l	h	H	(1)
Count	H	↑	h	h	h	X	count	(1)
Hold (do nothing)	H	X	l	X	h	X	q _n	(1)
	H	X	X	l ⁽²⁾	h	X	q _n	L

Counters

54F161A, 54F163A

MODE SELECT — FUNCTION TABLE, 54F163A

OPERATING MODE	INPUTS						OUTPUTS	
	SR	CP	CEP	CET	PE	D _n	Q _n	TC
Reset (clear)	l	↑	X	X	X	X	L	L
Parallel load	h	↑	X	X	l	l	L	L
	h	↑	X	X	l	h	H	(2)
Count	h	↑	h	h	h	X	count	(2)
Hold (do nothing)	h	X	l	X	h	X	q _n	(2)
	h	X	X	l	h	X	q _n	L

H = High voltage level steady state
 L = Low voltage level steady state
 h = High voltage level one setup time prior to the Low-to-High clock transition
 l = Low voltage level one setup time prior to Low-to-High clock transition
 X = Don't care
 q = Lower case letters indicate the state of the referenced output prior to the Low-to-High clock transition
 ↑ = Low-to-High clock transition

NOTES:

- (1) The TC output is High when CET is High and the counter is at Terminal Count (HHHH for 54F161A)
- (2) The TC output is High when CET is High and the counter is at Terminal Count (HHHH for 54F163A)

ABSOLUTE MAXIMUM RATINGS (Operation beyond the limits set forth in this table may impair the useful life of the device. Unless otherwise noted these limits are over the operating free-air temperature range.)

SYMBOL	PARAMETER	RATING	UNIT
V _{CC}	Supply voltage range	-0.5 to +7.0	V
V _I	Input voltage range	-0.5 to +7.0	V
I _I	Input current range	-30 to +5	mA
V _O	Voltage applied to output in High output state range	-0.5 to +V _{CC}	V
I _O	Current applied to output in Low output state	40	mA
T _{STG}	Storage temperature range	-65 to +150	°C

RECOMMENDED OPERATING CONDITIONS

SYMBOL	PARAMETER	LIMITS			UNIT
		Min	Nom	Max	
V _{CC}	Supply voltage	4.5	5.0	5.5	V
V _{IH}	High-level input voltage	2.0			V
V _{IL}	Low-level input voltage			0.8	V
I _{IK}	Input clamp current			-18	mA
I _{OH}	High-level output current			-1.0	mA
I _{OL}	Low-level output current			20.0	ma
T _A	Operating free-air temperature range	-55		+125	°C

Counters

54F161A, 54F163A

DC ELECTRICAL CHARACTERISTICS (Over recommended operating free-air temperature range unless otherwise noted.)

SYMBOL	PARAMETER	TEST CONDITIONS ¹	LIMITS			UNIT	
			Min	Typ ²	Max		
V _{OH}	High-level output voltage	V _{CC} = Min, V _{IL} = Max, I _{OH} = Max, V _{IH} = Min	2.5			V	
V _{OL}	Low-level output voltage	V _{CC} = Min, V _{IL} = Max, I _{OL} = Max, V _{IH} = Min		0.35	0.50	V	
V _{IK}	Input clamp voltage	V _{CC} = Min, I _I = I _{IK}		-0.73	-1.2	V	
I _{IH2}	Input current at maximum input voltage	V _{CC} = Max, V _I = 7.0V			100	μA	
I _{IH1}	High-level input current	CET, SR, PE	V _{CC} = Max, V _I = 2.7V			40	μA
		Other inputs				20	μA
I _{IL}	Low-level input current	CET, SR, PE	V _{CC} = Max, V _I = 0.5V			-1.2	mA
		Other inputs				-0.6	mA
I _{OS}	Short-circuit output current ³	V _{CC} = Max	-60		-150	mA	
I _{CC}	Supply current ⁴ (total)	I _{CC} H	V _{CC} = Max			55	mA
		I _{CC} L				55	mA

AC ELECTRICAL CHARACTERISTICS (When measured in accordance with the procedures outlined in Signetics LOGIC App Note 202 "Testing and Specifying FAST Logic.")

SYMBOL	PARAMETER	TEST CONDITIONS	LIMITS				UNIT	
			T _A = +25°C V _{CC} = +5.0V C _L = 50pF, R _L = 500Ω			T _A = -55°C to +125°C V _{CC} = +5.0V ± 10% C _L = 50pF, R _L = 500Ω		
			Min	Typ	Max	Min		Max
f _{MAX}	Maximum clock frequency	Waveform 1	100	120		75 ⁵	MHz	
t _{PLH} t _{PHL}	Propagation delay CP to Q _n	Waveform 1 PE = High	2.0 3.5	4.0 7.0	6.0 10.0	2.0 3.5	7.5 11.5	ns ns
		Waveform 1 PE = Low	2.5 4.0	4.0 6.0	7.0 8.5	2.0 4.0	8.5 10.0	ns ns
t _{PLH} t _{PHL}	Propagation delay CP to TC	Waveform 1	5.0 5.0	10.0 14.0	14.0 16.0	5.0 5.0	16.5 18.5	ns ns
		Waveform 2	2.5 2.5	4.5 4.5	7.5 7.5	2.5 2.5	9.0 9.0	ns ns
t _{PHL}	Propagation delay MR to Q _n (54F161A)	Waveform 3	5.5	9.0	12.0	5.5	14.0	ns
t _{PHL}	Propagation delay MR to TC (54F161A)	Waveform 3	4.5		11.5	4.5	14.0	ns

Counters

54F161A, 54F163A

AC SETUP REQUIREMENTS

SYMBOL	PARAMETER	TEST CONDITIONS	LIMITS					UNIT
			T _A = +25°C V _{CC} = +5.0V C _L = 50pF, R _L = 500Ω			T _A = -55°C to +125°C V _{CC} = +5.0V ± 10% C _L = 50pF, R _L = 500Ω		
			Min	Typ	Max	Min	Max	
t _s (H) t _s (L)	Setup time, High or Low D _n to CP	Waveform 5	5.0 5.0			5.5 5.5		ns ns
t _h (H) t _h (L)	Hold time, High or Low D _n to CP	Waveform 5	2.0 2.0			2.5 2.5		ns ns
t _s (H) t _s (L)	Setup time, High or Low PE or SR to CP	Waveform 5 or 6	11.0 8.5			13.5 10.5		ns ns
t _h (H) t _h (L)	Hold time, High or Low PE or SR to CP	Waveform 5 or 6	2.0 0			2.0 0		ns ns
t _s (H) t _s (L)	Setup time, High or Low CEP or CET to CP	Waveform 4	11.0 5.0			13.0 6.5		ns ns
t _h (H) t _h (L)	Hold time, High or Low CEP or CET to CP	Waveform 4	2.0 0			2.0 0		ns ns
t _w (H) t _w (L)	Clock pulse width (load), High or Low	Waveform 1	6.5 3.5			9.0 4.0		ns ns
t _w (H) t _w (L)	Clock pulse width (count), High or Low	Waveform 1	6.5 3.5			9.0 4.0		ns ns
t _w (L)	MR pulse width Low (54F161A)	Waveform 3	5.0			9.5		ns
t _{rec}	Recovery time, MR to CP (54F161A)	Waveform 3	6.0			6.0		ns

NOTES:

- For conditions shown as Min or Max, use the appropriate value specified under recommended operating conditions for the applicable type and function table for operating mode.
- All typical values are at V_{CC} = 5V, T_A = 25°C.
- Not more than one output should be shorted at a time. For testing I_{OS}, the use of high-speed test apparatus and/or sample-and-hold techniques are preferable in order to minimize internal heating and more accurately reflect operational values. Otherwise, prolonged shorting of a High output may raise the chip temperature well above normal and thereby cause invalid readings in other parameter tests. In any sequence of parameter tests, I_{OS} tests should be performed last.
- I_{CCH} is measured with PE input High, again with PE input Low, all other inputs High and outputs open. I_{COL} is measured with Clock input High, again with Clock input Low all other inputs Low, and outputs open.
- These parameters are guaranteed, but not tested.

Counters

54F161A, 54F163A

AC WAVEFORMS

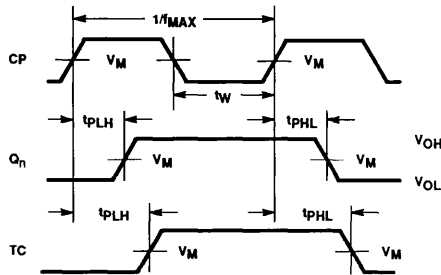

Waveform 1. Clock to Output Delays, Maximum Clock Frequency, and Clock Pulse Width

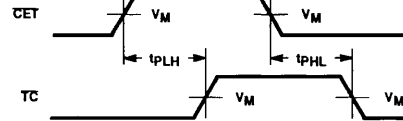

Waveform 2. Propagation Delays CET Input to TC Output

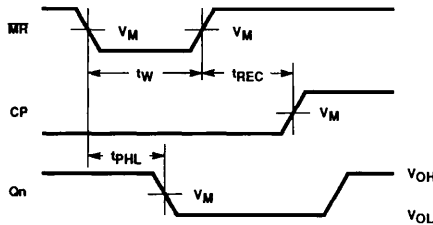

Waveform 3. Master Reset Pulse Width, Master Reset to Output Delay and Master Reset to Clock Recovery Time (54F161A)

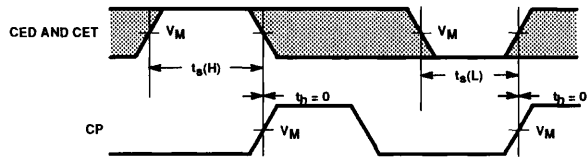

Waveform 4. CEP and CET Setup and Hold Times

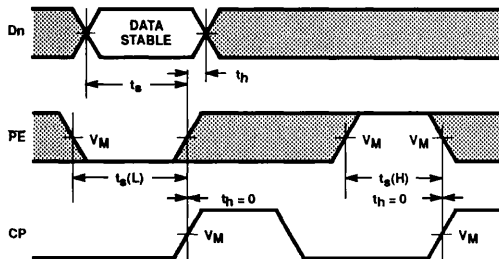

Waveform 5. Parallel Data and Parallel Enable Setup and Hold Times

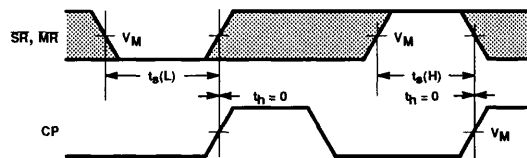

Waveform 6. Synchronous Reset Setup, Pulse Width and Hold Times (54F163A)

NOTE: For all waveforms $V_M = 1.5V$
The shaded areas indicate when the input is permitted to change for predictable output performance.

Counters

54F161A, 54F163A

APPLICATION DIAGRAM

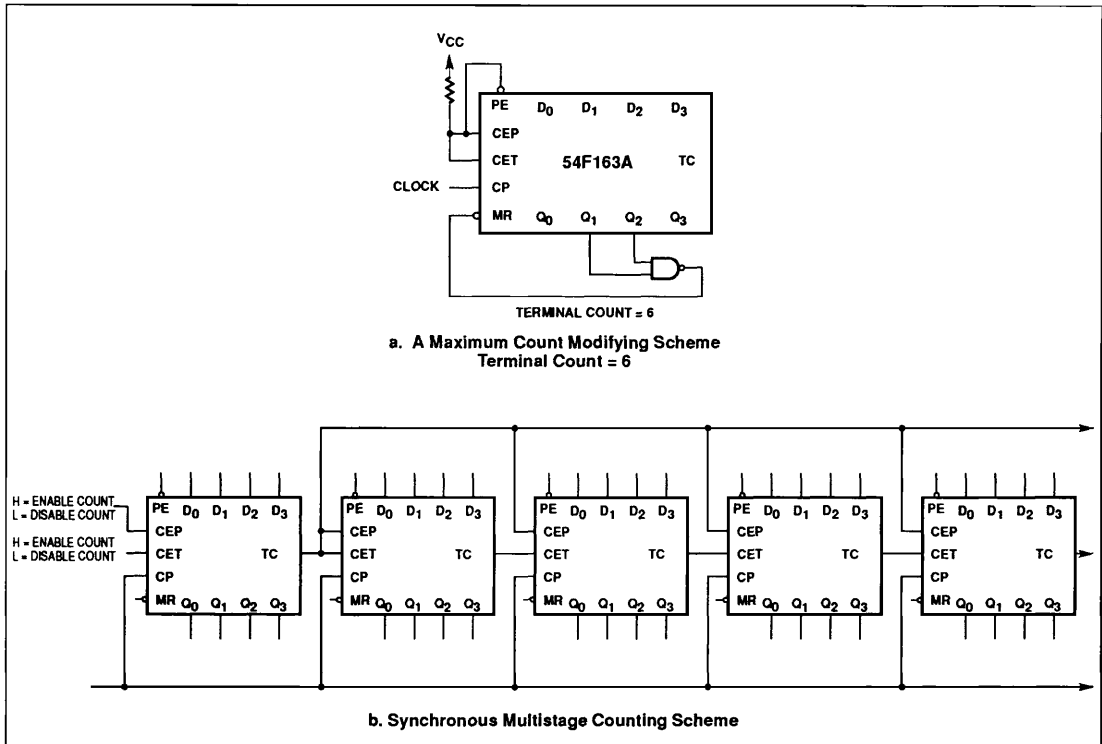

TEST CIRCUIT AND WAVEFORM

Test Circuit for Totem-Pole Outputs

Input Pulse Definition

$V_M = 1.5V$

DEFINITIONS:

- R_L = Load Resistor; see AC Characteristics for value.
- C_L = Load capacitance includes jig and probe capacitance; see AC Characteristics for value.
- R_T = Termination resistance should be equal to Z_{OUT} of pulse generators.
- V_X = Unlocked pins must be held at: $\leq 0.8V$; $\geq 2.7V$ or open per Function Table.

INPUT PULSE CHARACTERISTICS				
Family	Rep. Rate	Pulse Width	t_{TLH}	t_{THL}
54F	1MHz	500ns	$\leq 2.5ns$	$\leq 2.5ns$