



DM2223/2233 Sync Bursting EDRAM 512Kb x 8 Enhanced Dynamic RAM

Preliminary Datasheet

Features

- 8Kbit SRAM Cache Memory for 15ns Random Reads Within Four Active Pages
- Fast 4Mbit DRAM Array for 35ns Access to Any New Page
- Write Posting Register for 15ns Random or Burst Writes Within a Page
- 5ns Output Enable Access Time Allows Fast Interleaving
- Linear or Interleaved Burst Mode Without Register Loading Delays
- Fast Page to Page Move or Read-Modify-Write Cycles

- On-chip Cache Hit/Miss Comparators Automatically Maintain Cache Coherency Without External Cache Control
- Output Latch Enable Allows Extended Data Output for Faster System Operation (Hyper Page Mode)
- Hidden Precharge and Refresh Cycles
- Write-per-bit Option (DM2233) for Parity and Video Applications
- Extended 64ms Refresh Period for Low Standby Power
- Low Profile 300-Mil 44-Pin TSOP-II Package

Description

The Ramtron 4Mb enhanced DRAM (EDRAM) combines raw speed with innovative architecture to offer the optimum cost-performance solution for high performance local or main memory in computer and embedded control systems. In most high speed applications, zero-wait-state operation can be achieved without secondary SRAM cache for system clock speeds of up to 66MHz without interleaving or 132MHz with two-way interleaving. The EDRAM outperforms conventional SRAM cache plus DRAM or synchronous DRAM memory systems by minimizing wait states on initial reads (hit or miss) and by eliminating writeback delays. Architectural similarity with JEDEC DRAMs allows a single memory controller design to support either slow JEDEC DRAMs or high speed EDRAMs. A system designed in this manner can provide a simple upgrade path to higher system performance.

The 512K x 8 EDRAM has a control and address interface compatible with Ramtron's 4M x 1 and 1M x 4 EDRAM products so that EDRAMs of different organizations can be supported with the same controller design. The 512K x 8 EDRAM implements the following additional features which can be supported on new designs:

- An optional synchronous burst mode for 66MHz burst transfers or 132MHz two-way interleaved burst transfers.
- A controllable output latch provides an enhanced "extended data out" or "hyper page mode."
- Cache size is increased from 2Kbits to 8Kbits. The 8Kbit cache is organized as four 256 x 8 direct mapped row registers. All row registers can be accessed without clocking /RE.
- Concurrent random page write and cache reads from four cache pages allows fast page-to-page move or read-modify-write cycles.

Architecture

The EDRAM architecture includes an integrated SRAM cache which operates much like a page mode or static column DRAM.

The EDRAM's SRAM cache is integrated into the DRAM array as tightly coupled row registers. The 512K x 8 EDRAM has a total of four independent DRAM memory banks each with its own 256 x 8 SRAM row register. Memory reads always occur from the cache row register of one of these banks as specified by column address bits A_3 and A_0

2

Functional Diagram

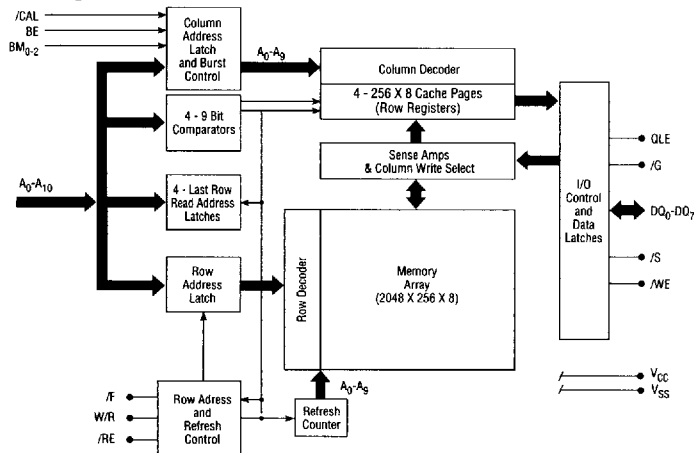

Pin Configuration

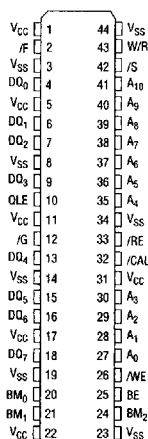

The information contained herein is subject to change without notice. Ramtron reserves the right to change or discontinue this product without notice.

© 1994 Ramtron International Corporation, 1850 Ramtron Drive, Colorado Springs, CO 80921
Telephone (719) 481-7000, Fax (719) 488-9095 R2 082594

(bank select). When the internal comparator detects that the row address matches the last row read from any of the four DRAM banks (page hit), only the SRAM is accessed and data is available on the output pins in 15ns from column address input. Subsequent reads within the current page or any of the other three active pages (burst reads or random reads) can continue at 15ns cycle time. When the row address does not match the last row read from any of the four DRAM banks (page miss), the new DRAM row is accessed and loaded into the appropriate SRAM row register and data is available on the output pins all within 35ns from row enable. Subsequent reads within the current page or any of the other three active pages (burst reads or random reads) can continue at 15ns cycle time. During either read hit or read miss operations, the EDRAM's flexible output data latch can be used to extend data output time so that the entire 66Mbyte/second bandwidth can be used.

Since reads occur from the SRAM cache, the DRAM precharge can occur during burst reads. This eliminates the precharge time delay suffered by other DRAMs and SDRAMs when accessing a new page. The EDRAM has an independent on-chip refresh counter and dedicated refresh pin to allow the DRAM array to be refreshed concurrently with cache read operations (hidden refresh).

During EDRAM read accesses, data can be accessed in either static column or page mode depending upon the operation of the /CAL input. If /CAL is held high, new data is accessed with each new column address (static column mode). If /CAL is brought low

during a read access, the column address is latched and new data will not be accessed until both the column address is changed and /CAL is brought high (page mode). A dedicated output enable (/G) with 5ns access time allows high speed two-way interleave without an external multiplexer.

Memory writes are posted to the input data latch and directed to the DRAM array. During a write hit, the on-chip address comparator activates a parallel write path to the SRAM cache to maintain coherency. Random or page mode writes can be posted 5ns after column address and data are available. The EDRAM allows 15ns page mode cycle time for both write hits and write misses. Memory writes do not affect the contents of the cache row register except during a cache hit. Since the DRAM array can be written to at SRAM speeds, there is no need for complex writeback schemes.

By concurrently accessing any of the EDRAM's four active read pages and any write page, data moves or read-modify-write cycles between rows may be accomplished at page mode speeds without requiring additional /RE cycles.

An internal burst address counter with burst enable (BE) and burst mode control (BM_{0,2}) can be used to facilitate all popular burst read and write sequences. By setting burst type and wrap length with dedicated control pins, burst mode can be changed without the mode register loading cycles found in the SDRAM. As an example, graphic or video applications may switch back and forth between four word Intel burst write sequences and full page

Four Bank Cache Architecture

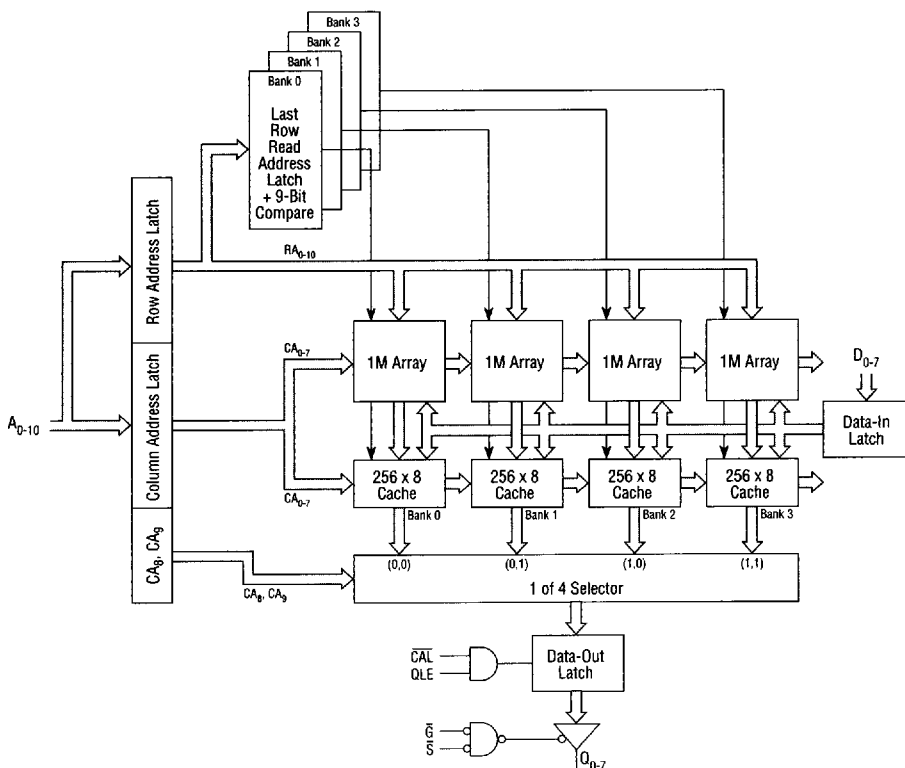

linear reads without register loading delays. Many other flexible burst options exist with this form of burst operation control. If bursting is not desired, it is only necessary to tie BE low.

By integrating the SRAM cache as row registers in the DRAM array and keeping the on-chip control simple, the EDRAM is able to provide superior performance without any significant increase in die size over standard slow 4Mb DRAMs. By eliminating the need for SRAMs and cache controllers, system cost, board space, and power can all be reduced.

Functional Description

The EDRAM is designed to provide optimum memory performance with high speed microprocessors. As a result, it is possible to perform simultaneous operations to the DRAM and SRAM cache sections of the EDRAM. This feature allows the EDRAM to hide precharge and refresh operation during reads and maximize hit rate by maintaining valid cache contents during write operations even if data is written to another memory page. These new capabilities, in conjunction with the faster basic DRAM and cache speeds of the EDRAM, minimize processor wait states.

EDRAM Basic Operating Modes

The EDRAM operating modes are specified in the table below.

Hit and Miss Terminology

In this datasheet, "hit" and "miss" always refer to a hit or miss to any of the four pages of data contained in the SRAM cache row registers. There are four cache row registers, one for each of the four banks of DRAM. These registers are specified by the bank select column address bits A_8 and A_9 . The contents of these cache row registers is always equal to the last row that was read from each of the four internal DRAM banks (as modified by any write hit data).

Row And Column Addressing

Like common DRAMs, the EDRAM requires the address to be multiplexed into row and column addresses. Unlike other memories, the DM2223 and DM2233 allow four read pages (DRAM pages duplicated in SRAM cache) and one write page to be active at the same time. To allow any of the four active cache pages to be accessed quickly, the row address bits $A_{8,9}$ (DRAM bank selects) are also duplicated in the column address bits $A_{8,9}$. This allows any cache bank to be selected by simply changing the column address. The write bank address is specified by row address $A_{8,9}$, and writes are inhibited when a different column bank select is enabled.

EDRAM Basic Operating Modes

Function	/S	/RE	W/R	/F	A_{0-10}	Comment
Read Hit	L	↓	L	H	Row = LRR	No DRAM Reference, Data in Cache
Read Miss	L	↓	L	H	Row ≠ LRR	DRAM Row to Cache
Write Hit	L	↓	H	H	Row = LRR	Write to DRAM and Cache, Reads Enabled
Write Miss	L	↓	H	H	Row ≠ LRR	Write to DRAM, Cache Not Updated, Reads Enabled
Internal Refresh	X	↓	X	L	X	
Low Power Standby	H	H	X	X	X	1mA Standby Current
Unallowed Mode	H	L	X	H	X	

H = High; L = Low; X = Don't Care; ↓ = High-to-Low Transition; LRR = Last Row Read

DRAM Read Hit

A DRAM read request is initiated by clocking /RE with W/R low and /F high⁽¹⁾. The EDRAM will compare the new row address to the last row read address latch for the bank specified by row address $A_{8,9}$ (LRR: a 9-bit row address latch for each internal DRAM bank which is reloaded on each /RE active read miss cycle). If the row address matches the LRR, the requested data is already in the SRAM cache and no DRAM memory reference is initiated. The data specified by the row and column address is available at the output pins at the greater of times t_{AC} or t_{GQV} . Since no DRAM activity is initiated, /RE can be brought high after time t_{RE1} , and a shorter precharge time, t_{RP1} , is required. Additional locations within any of the four active cache pages may be accessed concurrently with precharge by providing new column addresses and column bank select bits $CA_{8,9}$ to the multiplex address inputs. New data is available at the output at time t_{AC} after each column address changes. During any read cycle, the EDRAM may be operated in either static column mode with /CAL=high or page mode with /CAL clocked to latch the column address.

DRAM Read Miss

A DRAM read request is initiated by clocking /RE with W/R low and /F high⁽¹⁾. The EDRAM will compare the new row address to the LRR address latch for the bank specified by row address $A_{8,9}$ (LRR: a 9-bit row address latch for each internal DRAM bank which is reloaded on each /RE active read miss cycle). If the row address does not match the LRR, the requested data is not in SRAM cache and a new row is fetched from the DRAM. The EDRAM will load the new row data into the SRAM cache and update the LRR latch. The data at the specified column address is available at the output pins at the greater of times t_{RAC} , t_{AC} , and t_{GQV} . /RE may be brought high after time t_{RE} since the new row data is safely latched into SRAM cache. This allows the EDRAM to precharge the DRAM array while data is accessed from SRAM cache. Additional locations within any of the four cache pages may be accessed by providing new column addresses and column bank select bits $CA_{8,9}$ to the multiplex address inputs. New data is available at the output at time t_{AC} after each column address change. During any read cycle, the EDRAM may be operated in either static column mode with /CAL=high or page mode with /CAL clocked to latch the column address.

DRAM Write Hit

A DRAM write request is initiated by clocking /RE while W/R, /WE, and /F are high⁽¹⁾. The EDRAM will compare the new row

address to the LRR address latch for the bank specified by row address $A_{8,9}$ (LRR: a 9-bit row address latch for each internal DRAM bank which is reloaded on each /RE active read miss cycle). If the row address matches the LRR, the EDRAM will write data to both the DRAM page in the specified bank and its corresponding SRAM cache simultaneously to maintain coherency. The write address and data are posted to the DRAM as soon as the column address is latched by bringing /CAL low and the write data is latched by bringing /WE low. The write address and data can be latched very quickly after the fall of /RE ($t_{RAH} + t_{ASC}$ for the column address and t_{DS} for the data). During a write burst or any page write sequence, the second write data can be posted at time t_{RSW} after /RE. Subsequent writes within the page can occur with write cycle time t_{PC} . With /G enabled and /WE disabled, cache read operations may be performed while /RE is activated. This allows random read from any of the four cache pages and random write, read-modify-write, or write-verify to the current write page with 15ns cycle times. To perform internal memory-to-memory transfers, /WE can be brought low while /G is low to latch the read data into the write posting register. The read/write transfer is complete when the new write column address is latched by bringing /CAL low concurrently with /WE. At the end of any write sequence (after /CAL and /WE are brought high and t_{RE} is satisfied), /RE can be brought high to precharge the memory. Reads can be performed from any of the cache pages concurrently with precharge by providing the desired column address and column bank select bits $CA_{8,9}$ to the multiplex address inputs. During write sequences, a write operation is not performed unless both /CAL and /WE are low. As a result, the /CAL input can be used as a byte write select in multi-chip systems. If /CAL is not clocked on a write sequence, the memory will perform an /RE only refresh to the selected row and data will remain unmodified. Writes are inhibited for any write having a column address bank select different from the bank selected by the row address.

DRAM Write Miss

A DRAM write request is initiated by clocking /RE while W/R, /WE, and /F are high⁽¹⁾. The EDRAM will compare the new row address to the LRR address latch for the bank specified by row address $A_{8,9}$ (LRR: a 9-bit row address latch for each internal DRAM bank which is reloaded on each /RE active read miss cycle). If the row address does not match the LRR, the EDRAM will write data only to the DRAM page in the appropriate bank and the contents of the current cache is not modified. The write address and data are posted to the DRAM as soon as the column address is latched by bringing /CAL low and the write data is latched by bringing /WE low. The write address and data can be latched very quickly after the fall of /RE ($t_{RAH} + t_{ASC}$ for the column address and t_{DS} for the data). During a write burst or any page write sequence, the second write data can be posted at time t_{RSW} after /RE. Subsequent writes within the page can occur with write cycle time t_{PC} . With /G enabled and /WE disabled, cache read operations may be performed while /RE is activated. This allows random read accesses from any of the four cache pages and random writes to the current write page with 15ns cycle times. To perform internal memory-to-memory transfers, /WE can be brought low while /G is low to latch the read data into the write posting register. The read/write transfer is complete when the new write column address is latched by bringing /CAL low concurrently with /WE. At the end of any write sequence (after /CAL and /WE are brought high and t_{RE} is satisfied), /RE can be brought high to precharge the memory. Reads

can be performed from any of the cache pages concurrently with precharge by providing the desired column address and column bank select bits $CA_{8,9}$ to the multiplex address inputs. During write sequences, a write operation is not performed unless both /CAL and /WE are low. As a result, /CAL can be used as a byte write select in multi-chip systems. If /CAL is not clocked on a write sequence, the memory will perform an /RE only refresh to the selected row and data will remain unmodified. Writes are inhibited for any write having a column address bank select different from the bank selected by the row address.

/RE Inactive Operation

Data may be read from any of the four SRAM cache pages without clocking /RE. This capability allows the EDRAM to perform cache read operations during precharge and refresh cycles to minimize wait states. It is only necessary to select /S and /G and provide the appropriate column address to read data as shown in the table below. In this mode of operation, the cache reads may occur from any of the four pages as specified by column bank select bits $CA_{8,9}$. To perform a cache read in static column mode, /CAL is held high, and the cache contents at the specified column address will be valid at time t_{AC} after address is stable. To perform a cache read in page mode, /CAL is clocked to latch the column address.

This option allows the external logic to perform fast hit/miss comparison so that the time required for row/column multiplexing is avoided.

Function	/S	/G	/CAL	$A_{8,9}$
Cache Read (Static Column)	L	L	H	Col Adr
Cache Read (Page Mode)	L	L	↓	Col Adr

Output Latch Enable Operation

The 512K x 8 EDRAM has an output latch enable (QLE) that can be used to extend data output valid time. The output latch enable operates as shown in the following table.

When QLE is low, the latch is transparent and the EDRAM operates identically to the standard 4M x 1 and 1M x 4 EDRAMs. When /CAL is high during a static column mode read, the QLE input can be used to latch the output to extend the data output valid time. QLE can be held high during page mode reads. In this case, the data outputs are latched while /CAL is high and open when /CAL is not high.

QLE	/CAL	Comments
L	X	Output Transparent
↓	H	Output Latched When QLE=H (Static Column)
H	↓	Output Latched When /CAL=H (Page Mode)

Burst Mode Operation

Burst mode provides a convenient method for high speed sequential reading or writing of data. To enter burst mode, the starting address, a burst enable signal (BE) and burst mode information ($BM_{0,2}$) as shown in the following table must be provided. Random accesses using external addresses or new burst sequences may be performed after a burst sequence is terminated.

To start a burst cycle, BE must be brought high prior to the falling edge of /CAL. At the falling edge of /CAL, the EDRAM latches the starting address and the states of the burst mode pins (BM_{0,2}) which define the type and wrap length of the burst. Once a burst sequence has been started, the internal address counter increments with each low to high transition of /CAL. Burst mode is terminated immediately when either BE goes low or /S goes high (/S must not go high while /RE is low). Burst mode must be terminated before a subsequent burst sequence can be initiated. Furthermore, the state of the address counter is indeterminate following a burst termination and must be reloaded for a subsequent burst operation. Burst reads may be performed from any of the four cache pages and may occur with /RE either active or inactive. As with all writes, however, burst writes may only be performed to the currently active write page (defined by the row address) while /RE is active.

Burst mode may be used with or without output latch enable operation. If burst mode is not used, BE and BM_{0,2} may be tied to ground to disable the burst function.

EDRAM Burst Modes

BM _{2,1,0}	Burst Type	Wrap Length	Address Sequence
0-0-0	Linear	2	0-1 1-0
0-0-1	Linear	4	0-1-2-3 1-2-3-0 2-3-0-1 3-0-1-2
0-1-0	Linear	8	0-1-2-3-4-5-6-7 1-2-3-4-5-6-7-0 2-3-4-5-6-7-0-1 3-4-5-6-7-0-1-2 4-5-6-7-0-1-2-3 5-6-7-0-1-2-3-4 6-7-0-1-2-3-4-5 7-0-1-2-3-4-5-6
0-1-1	Linear	Full Page	(B)(S),(B)(S+1),... (B)(255),(B)(0),...
1-0-0	Interleaved (Scrambled)	2	0-1 1-0
1-0-1	Interleaved (Scrambled)	4	0-1-2-3 1-0-3-2 2-3-0-1 3-2-1-0
1-1-0	Interleaved (Scrambled)	8	0-1-2-3-4-5-6-7 1-0-3-2-5-4-7-6 2-3-0-1-6-7-4-5 3-2-1-0-7-6-5-4 4-5-6-7-0-1-2-3 5-4-7-6-1-0-3-2 6-7-4-5-2-3-0-1 7-6-5-4-3-2-1-0
1-1-1	Linear	All Pages	(B)(S),(B)(S+1),... (B)(255),(B+1)(0),...

NOTES: a) B=Bank Address, S=Starting Column Address;

b) For BM_{2,1,0}=111, wrap length is 1,024 8-bit words with 256 8-bit words for each of the four cache blocks. During read or write sequences, the address count will switch from bank to bank after column address 256. Write operations, however, will only occur when the internally generated bank address A₈ and A₉ matches the row address A₈ and A₉ that were loaded when /RE went low.

Write-Per-Bit Operation

The DM2233 version of the 512Kb x 8 EDRAM offers a write-per-bit capability which allows single bits of the memory to be selectively written without altering other bits in the same word. This capability may be useful for implementing parity or masking data in video graphics applications. The bits to be written are determined by a bit mask data word which is placed on the I/O data pins DQ_{0,7} prior to clocking /RE. The logic one bits in the mask data select the bits to be written. As soon as the mask is latched by an /RE low transition, the mask data is removed and write data can be placed on the databus. The mask is only specified on the /RE transition. During page mode burst write operations, the same mask is used for all write operations.

Internal Refresh

If /F is active (low) on the assertion of /RE, an internal refresh cycle is executed. This cycle refreshes the row address supplied by an internal refresh counter. This counter is incremented at the end of the cycle in preparation for the next /F refresh cycle. At least 1,024 /F cycles must be executed every 64ms. /F refresh cycles can be hidden because cache memory can be read under column address control throughout the entire /F cycle. /F cycles are the only active cycles during which /S can be disabled.

/CAL Before /RE Refresh ("CAS Before RAS")

/CAL before /RE refresh, a special case of internal refresh, is discussed in the "Reduced Pin Count Operation" section below.

/RE Only Refresh Operation

Although /F refresh using the internal refresh counter is the recommended method of EDRAM refresh, an /RE only refresh may be performed using an externally supplied row address. /RE refresh is performed by executing a *write cycle* (W/R and /F are high) where /CAL is not clocked. This is necessary so that the current cache contents and LRR are not modified by the refresh operation. All combinations of addresses A_{0,9} must be sequenced every 64ms refresh period. A₁₀ does not need to be cycled. Read refresh cycles are not allowed because a DRAM refresh cycle does not occur when a read refresh address matches the LRR address latch.

Low Power Mode

The EDRAM enters its low power mode when /S is high. In this mode, the internal DRAM circuitry is powered down to reduce standby current to 1mA.

Initialization Cycles

A minimum of eight /RE active initialization cycles (read, write, or refresh) are required before normal operation is guaranteed. Following these start-up cycles, two read cycles to different row addresses must be performed for each of the four internal banks of DRAM to initialize the internal cache logic. Row address bits A₈ and A₉ define the four internal DRAM banks.

Unallowed Mode

Read, write, or /RE only refresh operations must not be performed to unselected memory banks by clocking /RE when /S is high.

Reduced Pin Count Operation

Although it is desirable to use all EDRAM control pins to optimize system performance, the interface to the EDRAM may be simplified to reduce the number of control lines by either tying pins to ground or tying one or more control inputs together. The /S input can be tied to

ground if low power standby mode is not required. The QLE input can be tied low if output latching is not required, or tied high if "extended data out" (hyper page mode) is required. BE can be tied low if burst operation is not desired. The /CAL and /F pins can be tied together if hidden refresh operation is not required. In this case, a CBR refresh (/CAL before /RE) can be performed by holding the combined input low prior to /RE. The /WE input can be tied to /CAL if independent posting of column addresses and data are not required during write operations. In this case, both column address and write data will be latched by the combined input during writes. The W/R and /G inputs can be tied together if reads are not required during a write cycle. If these techniques are used, the EDRAM will require only three control lines for operation (/RE, /CAS [combined /CAL, /F, and /WE], and W/R [combined W/R and /G]). The simplified control interface still allows the fast page read/write cycle times, fast random read/write times, and hidden precharge functions available with the EDRAM.

Pin Descriptions

/RE — Row Enable

This input is used to initiate DRAM read and write operations and latch a row address as well as the states of W/R and /F. It is not necessary to clock /RE to read data from any of the SRAM row registers. On read operations, /RE can be brought high as soon as data is loaded into cache to allow early precharge.

/CAL — Column Address Latch

This input is used to latch the column address and in combination with /WE to trigger write operations. When /CAL is high, the column address latch is transparent. When /CAL transitions low, it latches the address present while /CAL was high. /CAL can be toggled when /RE is low or high. In burst mode, toggling /CAL will increment the internal address counter. However, /CAL must be high during the high-to-low transition of /RE except for /F refresh cycles. If QLE is high during a read, /CAL will hold data output until it transitions low.

W/R — Write/Read

This input along with /F specifies the type of DRAM operation initiated on the low going edge of /RE. When /F is high, W/R specifies either a write (logic high) or read operation (logic low).

/F — Refresh

This input will initiate a DRAM refresh operation using the internal refresh counter as an address source when /F is low on the low going edge of /RE.

/WE — Write Enable

This input controls the latching of write data on the input data pins. A write operation is initiated when both /CAL and /WE are low.

/G — Output Enable

This input controls the gating of read data to the output data pins during read operations.

/S — Chip Select

This input is used to power up the I/O and clock circuitry. When /S is high, the EDRAM remains in its low power mode. /S must remain active throughout any read or write operation. With the exception of /F refresh cycles, /RE should never be clocked when /S is inactive.

DQ₀₋₇ — Data Input/Output

These bidirectional data pins are used to read and write data to the EDRAM. On the DM2233 write-per-bit memory, these pins are also used to specify the bit mask used during write operations.

A₀₋₁₀ — Multiplex Address

These inputs are used to specify the row and column addresses of the EDRAM data. The 11-bit row address is latched on the falling edge of /RE. The 10-bit column address can be specified at any other time to select read data from the SRAM cache or to specify the write column address during write cycles. The addition of column address bits CA_{8,9} to specify the desired SRAM bank to be accessed allows quick read access to all four cache pages without the need of performing an /RE cycle.

QLE — Output Latch Enable

This input enables the output latch. When QLE is low, the output latch is transparent. Data is latched when both /CAL and QLE are high. This allows output data to be extended during either static column or page mode read cycles.

BE — Burst Enable

This input is used to enable and disable the burst mode function.

BM₀₋₂ — Burst Mode

These input pins define the burst type and address wrap around length during burst read and write transfers.

V_{CC} Power Supply

These inputs are connected to the +5 volt power supply.

V_{SS2} Ground

These inputs are connected to the power supply ground connection.

Pin Names

Pin Names	Function
A ₀₋₁₀	Address Inputs
DQ ₀₋₇	Data In/Data Out
/RE	Row Enable
/CAL	Column Address Latch
W/R	Write/Read Control
V _{CC}	Power (+5V)
V _{SS}	Ground

Pin Names	Function
/WE	Write Enable
/G	Output Enable
/F	Refresh Control
/S	Chip Select
BE	Burst Enable
QLE	Output Latch Enable
BM ₀₋₂	Burst Mode Control

AC Test Load and Waveforms

V_{IH} Timing Reference Point at V_{IL} and V_{IH}
 V_{OUT} Timing Referenced to 1.5 Volts

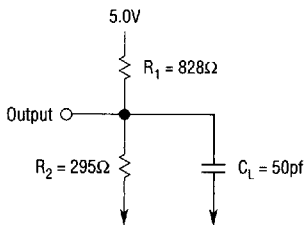
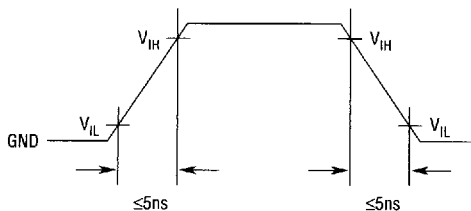
**Load Circuit****Input Waveforms****Absolute Maximum Ratings**

(Beyond Which Permanent Damage Could Result)

Description	Ratings
Input Voltage (V_{IN})	-1 ~ $V_{CC}+1$
Output Voltage (V_{OUT})	-1 ~ $V_{CC}+1$
Power Supply Voltage (V_{CC})	-1 ~ 7v
Ambient Operating Temperature (T_A)	0 ~ 70°C
Storage Temperature (T_S)	-55 ~ 150°C
Static Discharge Voltage (Per MIL-STD-883 Method 3015)	>2000V
Short Circuit O/P Current (I_{OUT})	50mA*

*One output at a time; short duration.

Capacitance

Description	Max	Pins
Input Capacitance	7pf	A_{0-10} , /WE, /S, BE
Input Capacitance	10pf	/RE, /CAL
Input Capacitance	3pf	/G, /F, QLE, W/R, BM_{0-2}
I/O Capacitance	6pf	DQ_{0-7}

Electrical Characteristics $(T_A = 0 - 70^\circ\text{C})$

Symbol	Parameters	Min	Max	Test Conditions
V_{CC}	Supply Voltage	4.75V	5.25V	All Voltages Referenced to V_{SS}
V_{IH}	Input High Voltage	2.4V	$V_{CC}+1$	
V_{IL}	Input Low Voltage	-1.0V	0.8V	
V_{OH}	Output High Level	2.4V	—	$I_{OUT} = -5\text{mA}$
V_{OL}	Output Low Level	—	0.4V	$I_{OUT} = 4.2\text{mA}$
$V_{I(L)}$	Input Leakage Current	-10 μA	10 μA	$0\text{V} \leq V_{IN} \leq 6.5\text{V}$, All Other Pins Not Under Test = 0V
$V_{O(L)}$	Output Leakage Current	-10 μA	10 μA	$0\text{V} \leq V_{IN}$, $0\text{V} \leq V_{OUT} \leq 5.5\text{V}$

Symbol	Operating Current	33MHz Typ ⁽¹⁾	-15 Max	-20 Max	Test Condition	Notes
I_{CC1}	Random Read	110mA	225mA	180mA	/RE, /CAL, /G and Addresses Cycling: $t_C = t_C$ Minimum	2, 3
I_{CC2}	Fast Page Mode Read	65mA	145mA	115mA	/CAL, /G and Addresses Cycling: $t_{PC} = t_{PC}$ Minimum	2, 4
I_{CC3}	Static Column Read	55mA	110mA	90mA	/G and Addresses Cycling: $t_{AC} = t_{AC}$ Minimum	2, 4
I_{CC4}	Random Write	135mA	190mA	150mA	/RE, /CAL, /WE and Addresses Cycling: $t_C = t_C$ Minimum	2, 3
I_{CC5}	Fast Page Mode Write	50mA	135mA	105mA	/CAL, /WE and Addresses Cycling: $t_{PC} = t_{PC}$ Minimum	2, 4
I_{CC6}	Standby	1mA	1mA	1mA	All Control Inputs Stable $\geq V_{CC} - 0.2\text{V}$	
I_{CCT}	Average Typical Operating Current	30mA	—	—	See "Estimating EDRAM Operating Power" Application Note	1

(1) "33MHz Typ" refers to worst case I_{CC} expected in a system operating with a 33MHz memory bus. See power applications note for further details. This parameter is not 100% tested or guaranteed.

(2) I_{CC} is dependent on cycle rates and is measured with CMOS levels and the outputs open.

(3) I_{CC} is measured with a maximum of one address change while /RE = V_{IL}

(4) I_{CC} is measured with a maximum of one address change while /CAL = V_{IH}

Switching Characteristics

 $(V_{CC} = 5V \pm 5\%, T_A = 0 - 70^\circ C, C_L = 50\text{pf})$

Symbol	Description	-15		-20		Units
		Min	Max	Min	Max	
$t_{AC}^{(1)}$	Column Address Access Time		15		20	ns
t_{ACH}	Column Address Valid to /CAL Inactive (Write Cycle)	15		20		ns
t_{ACI}	Address Valid to /CAL Inactive (QLE High)	15		20		ns
t_{AHQ}	Column Address Hold From QLE High (/CAL=H)	0		0		ns
t_{AQH}	Address Valid to QLE High	15		20		ns
t_{AQX}	Column Address Change to Output Data Invalid	5		5		ns
t_{ASC}	Column Address Setup Time	5		5		ns
t_{ASR}	Row Address Setup Time	5		6		ns
t_{BCH}	BE Hold From /CAL Low	0		1		ns
t_{BHS}	BE High Setup to /CAL Low	5		6		ns
t_{BLS}	BE Low Setup to /CAL Low (Non-Burst Mode)	7		9		ns
t_{BP}	BE Low Time	5		6		ns
t_{BQV}	Data Out Valid From BE Low (/CAL High, QLE Low)		20		25	ns
t_{BQX}	Data Change From BE Low (/CAL High, QLE Low)	5		5		ns
t_{BSR}	BE Low to /RE Setup Time	7		9		ns
t_C	Row Enable Cycle Time	65		85		ns
t_{C1}	Row Enable Cycle Time, Cache Hit (Row=LRR), Read Cycle Only	25		32		ns
t_{CAE}	Column Address Latch Active Time	6		7		ns
t_{CAH}	Column Address Hold Time	0		1		ns
t_{CH}	Column Address Latch High Time (Latch Transparent)	5		7		ns
t_{CHW}	Column Address Latch High to Write Enable Low (Multiple Writes)	0		0		ns
t_{CLV}	Column Address Latch Low to Data Valid (QLE High)		7		10	ns
t_{CQH}	Data Hold From /CAL ↓ Transaction (QLE High)	0		0		ns
t_{COV}	Column Address Latch High to Data Valid		15		20	ns
t_{COX}	Column Address Latch Inactive to Data Invalid	5		5		ns
t_{CRP}	Column Address Latch Setup Time to Row Enable	5		6		ns
t_{CWL}	/WE Low to /CAL Inactive	5		7		ns
t_{DH}	Data Input Hold Time	0		1		ns
t_{DMH}	Mask Hold Time From Row Enable (Write-Per-Bit)	1.5		2		ns
t_{DMS}	Mask Setup Time to Row Enable (Write-Per-Bit)	5		6		ns
t_{DS}	Data Input Setup Time	5		6		ns
$t_{GOV}^{(1)}$	Output Enable Access Time		5		6	ns
$t_{GOX}^{(2,3)}$	Output Enable to Output Drive Time	0	5	0	6	ns
$t_{GOZ}^{(4,5)}$	Output Turn-Off Delay From Output Disabled (/G↑)	0	5	0	6	ns
t_{MCH}	BM ₀₋₂ Mode Hold Time From /CAL Low	0		0		ns

Switching Characteristics (continued)

(V_{CC} = 5V ± 5%, T_A = 0 - 70°C), C_L = 50pF

Symbol	Description	-15		-20		Units
		Min	Max	Min	Max	
t _{MCL}	BM ₀₋₂ Mode to /CAL ↓ Transition	5		6		ns
t _{MH}	/F and W/R Mode Select Hold Time	0		1		ns
t _{MSU}	/F and W/R Mode Select Setup Time	5		6		ns
t _{NRH}	/CAL, /G, and /WE Hold Time For /RE-Only Refresh	0		0		ns
t _{NRS}	/CAL, /G, and /WE Setup Time For /RE-Only Refresh	5		6		ns
t _{PC}	Column Address Latch Cycle Time	15		20		ns
t _{QCI}	QLE High to /CAL Inactive	0		0		ns
t _{QH}	QLE High Time	5		6		ns
t _{QL}	QLE Low Time	5		6		ns
t _{QOH}	Data Hold From QLE Inactive	2		3		ns
t _{QOV}	Data Valid From QLE Low		7.5		10	ns
t _{RAC} ⁽¹⁾	Row Enable Access Time, On a Cache Miss		35		45	ns
t _{RAC1} ⁽¹⁾	Row Enable Access Time, On a Cache Hit (Limit Becomes t _{AC})		17		22	ns
t _{RAH}	Row Address Hold Time	1.5		2		ns
t _{RBH}	BE Hold Time From /RE	0		1		ns
t _{RE}	Row Enable Active Time	35	100000	45	100000	ns
t _{RE1}	Row Enable Active Time, Cache Hit (Row=LRR) Read Cycle	10		13		ns
t _{REF}	Refresh Period		64		64	ms
t _{RP}	Row Precharge Time	25		32		ns
t _{RP1}	Row Precharge Time, Cache Hit (Row=LRR) Read Cycle	10		13		ns
t _{RRH}	/WE Don't Care From Row Enable High (Write Only)	0		1		ns
t _{RSH}	Last Write Address Latch to End of Write	15		20		ns
t _{RSW}	Row Enable to Column Address Latch Low For Second Write	40		51		ns
t _{RWL}	Last Write Enable to End of Write	15		20		ns
t _{SC}	Column Address Cycle Time	15		20		ns
t _{SDC}	/S Enable to First /CAL Low	15		20		ns
t _{SH}	/S High to Exit Burst	7		7		ns
t _{SHR}	Select Hold From Row Enable	0		1		ns
t _{SQV} ⁽¹⁾	Chip Select Access Time		15		20	ns
t _{SOX} ^(2,3)	Output Turn-On From Select Low	0	15	0	20	ns
t _{SOZ} ^(4,5)	Output Turn-Off From Chip Select	0	10	0	13	ns
t _{SSR}	Select Setup Time to Row Enable	5		6		ns
t _T	Transition Time (Rise and Fall)	1	10	1	10	ns
t _{WC}	Write Enable Cycle Time	15		20		ns
t _{WCH}	Column Address Latch Low to Write Enable Inactive Time	5		7		ns

2

Switching Characteristics (continued)(V_{CC} = 5V ± 5%, T_A = 0 - 70°C), C_L = 50pf

Symbol	Description	-15		-20		Units
		Min	Max	Min	Max	
t _{WHR} ⁽⁶⁾	Write Enable Hold After /RE	0		1		ns
t _{WI}	Write Enable Inactive Time	5		7		ns
t _{WP}	Write Enable Active Time	5		7		ns
t _{WQV} ⁽¹⁾	Data Valid From Write Enable High		15		20	ns
t _{WQX} ^(2,5)	Data Output Turn-On From Write Enable High	0	15	0	20	ns
t _{WQZ} ^(3,4)	Data Turn-Off From Write Enable Low	0	15	0	20	ns
t _{WRP}	Write Enable Setup Time to Row Enable	5		5		ns

(1) V_{OLT} Timing Reference Point at 1.5V(2) Parameter Defines Time When Output is Enabled (Sourcing or Sinking Current) and is Not Referenced to V_{OH} or V_{OL}(3) Minimum Specification is Referenced from V_{IH} and Maximum Specification is Referenced from V_{IL} on Input Control Signal(4) Parameter Defines Time When Output Achieves Open-Circuit Condition and is Not Referenced to V_{OH} or V_{OL}(5) Minimum Specification is Referenced from V_{IL} and Maximum Specification is Referenced from V_{IH} on Input Control Signal(6) For Write-Per-Bit Devices, t_{WHR} is Limited By Data Input Setup Time, t_{DS}

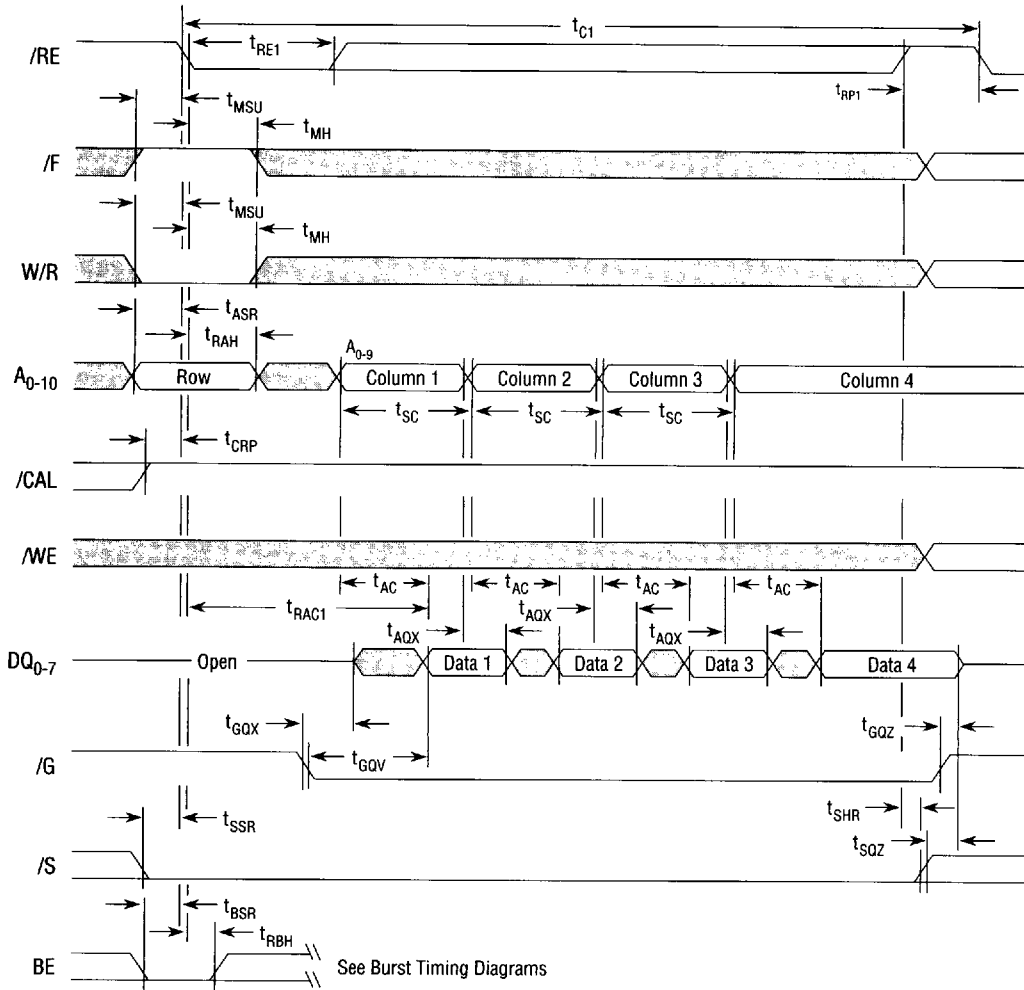
/RE Active Cache Read Hit (Static Column Mode)Don't Care or Indeterminate NOTES: 1. Column address A₈₋₉ specify cache bank accessed on each read.

2

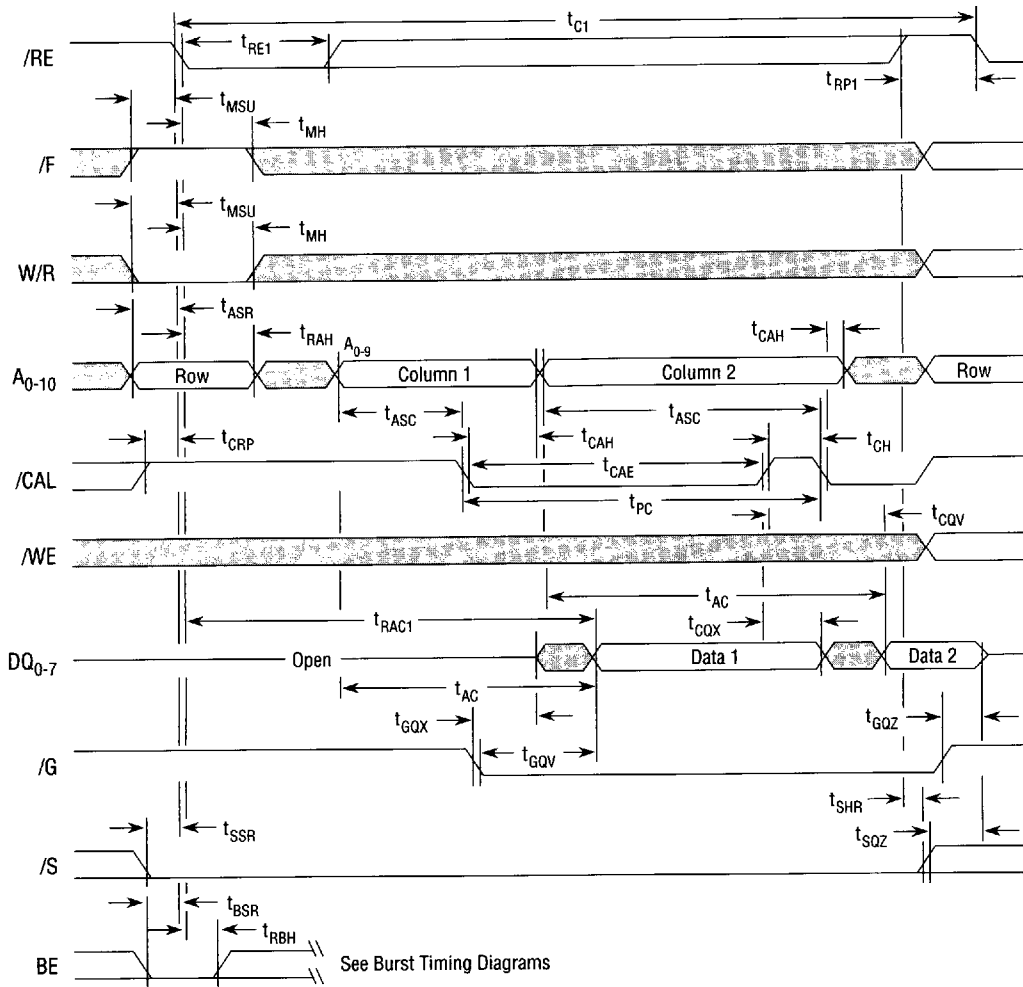
/RE Active Cache Read Hit (Page Mode)

NOTES: 1. Column address $A_{8,9}$ specify cache bank accessed on each read.

/RE Active Cache Read Miss (Static Column Mode)

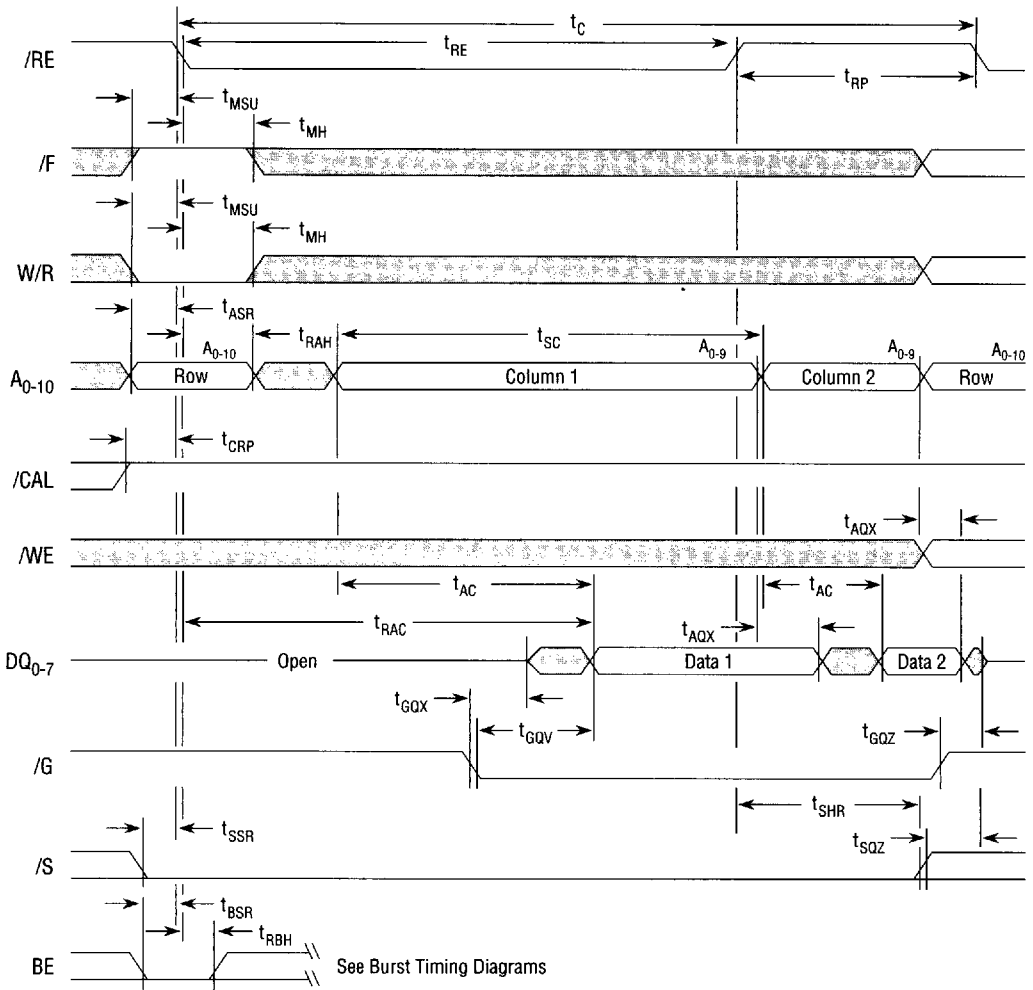

See Burst Timing Diagrams

Don't Care or Indeterminate

NOTES: 1. Column address A_{8,9} specify cache bank accessed on each read.

2

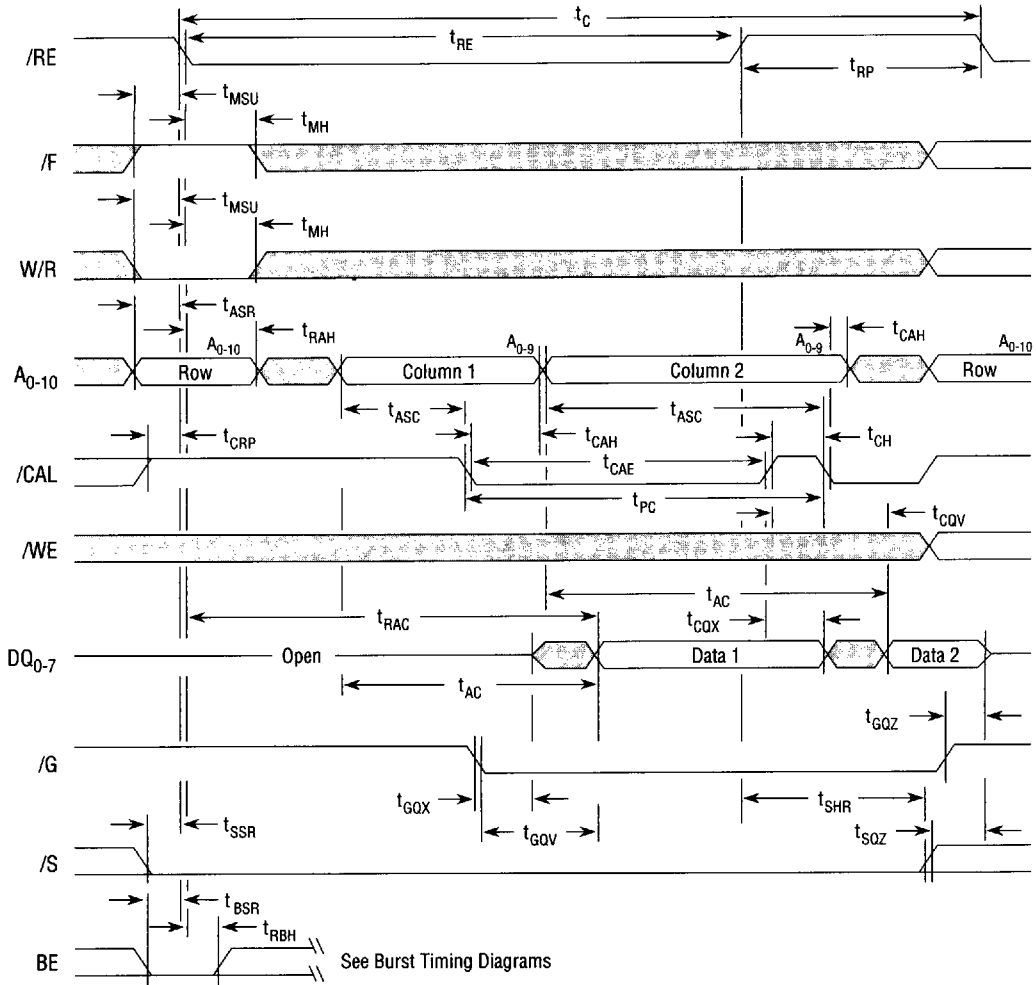
/RE Active Cache Read Miss (Page Mode)

NOTES: 1. Column address $A_{0,9}$ specify cache bank accessed on each read.

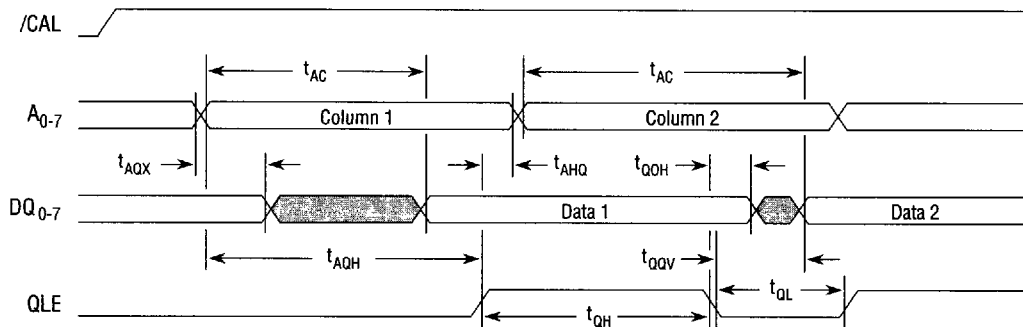
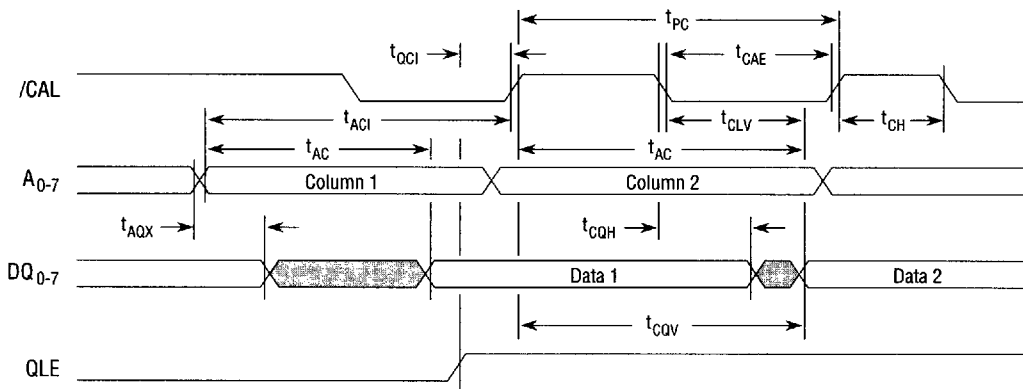
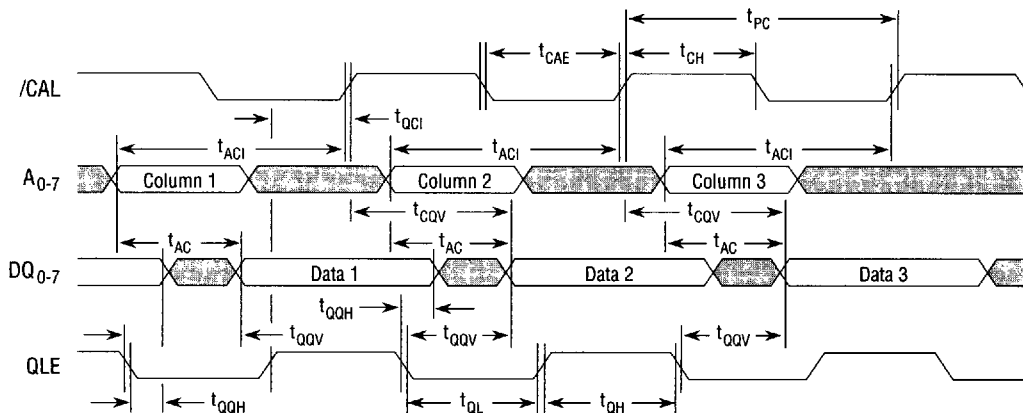
Output Latch Enable Operation (Static Column Mode Read)**Output Latch Enable Operation (Page Mode Read)****Output Latch Enable Operation (Asynchronous Access)**

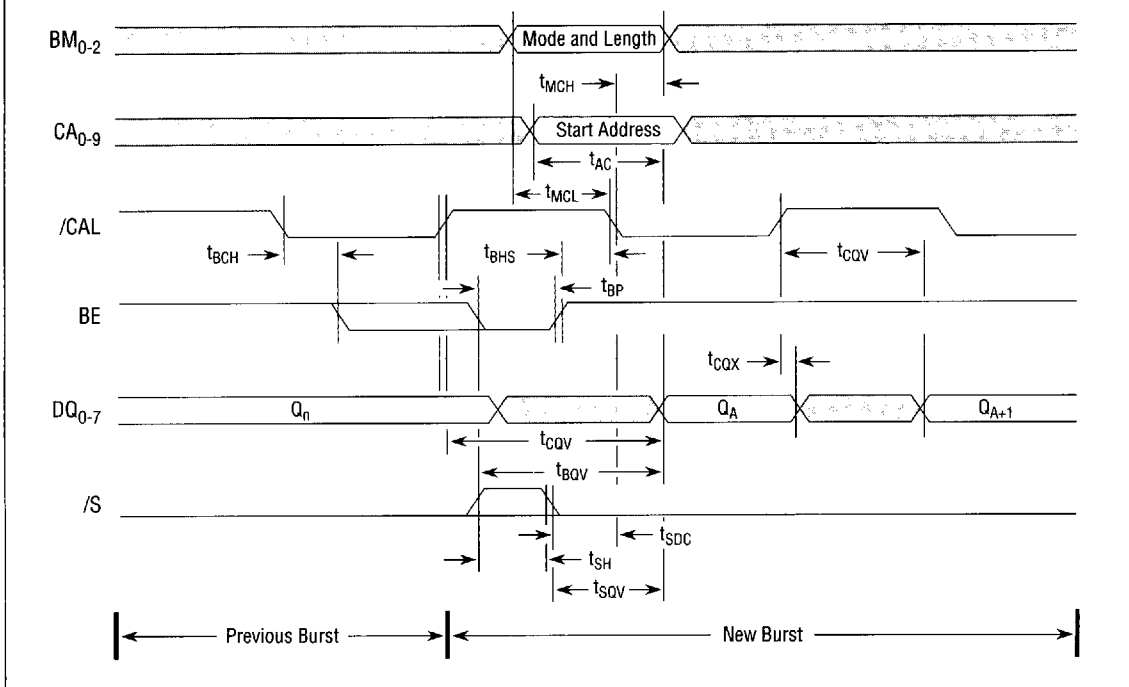
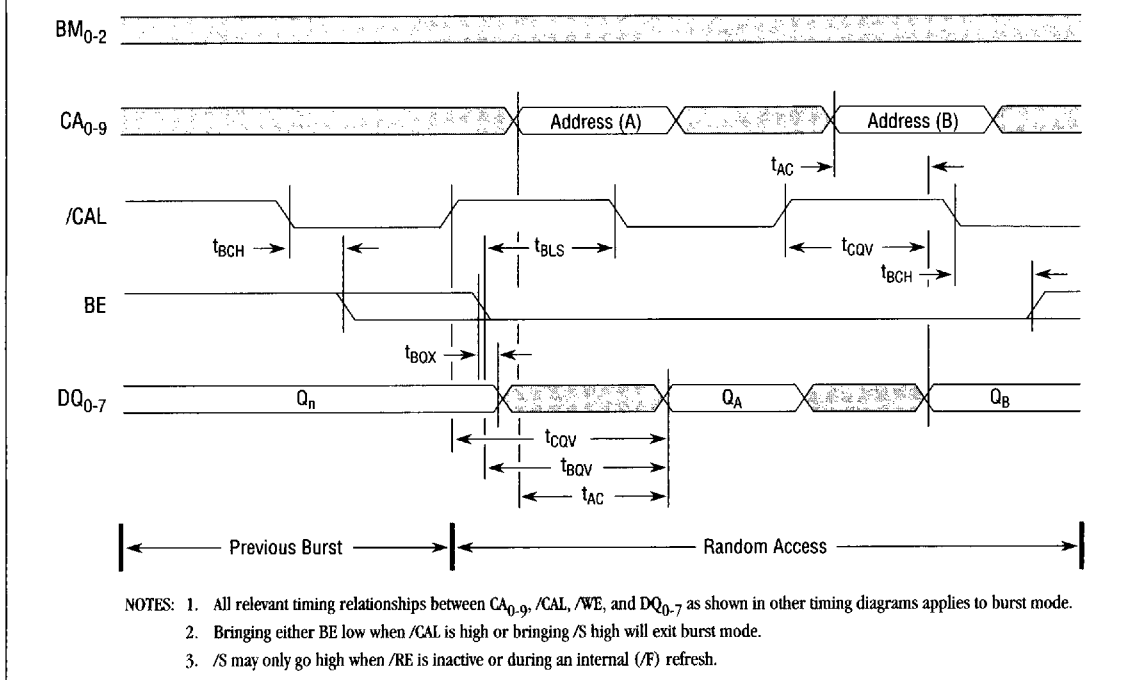
Burst-To-Burst Reads Or Writes**Burst-To-Random Reads Or Writes**

- NOTES:
1. All relevant timing relationships between CA₀₋₉, /CAL, /WE, and DQ₀₋₇ as shown in other timing diagrams applies to burst mode.
 2. Bringing either BE low when /CAL is high or bringing /S high will exit burst mode.
 3. /S may only go high when /RE is inactive or during an internal (/F) refresh.

Burst Write (Hit or Miss) Followed By /RE Inactive Cache Reads

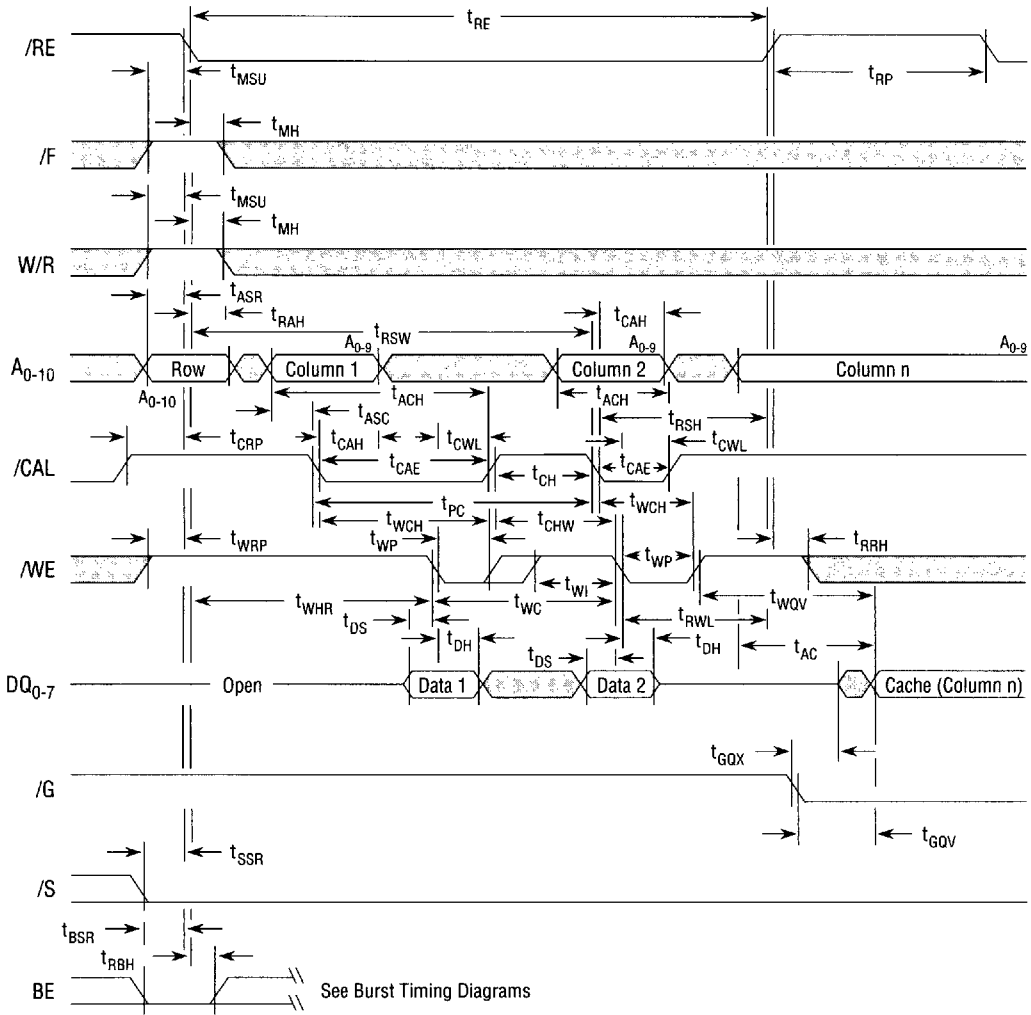

See Burst Timing Diagrams

Don't Care or Indeterminate

Read/Write During Write Hit Cycle (Can Include Read-Modify-Write)

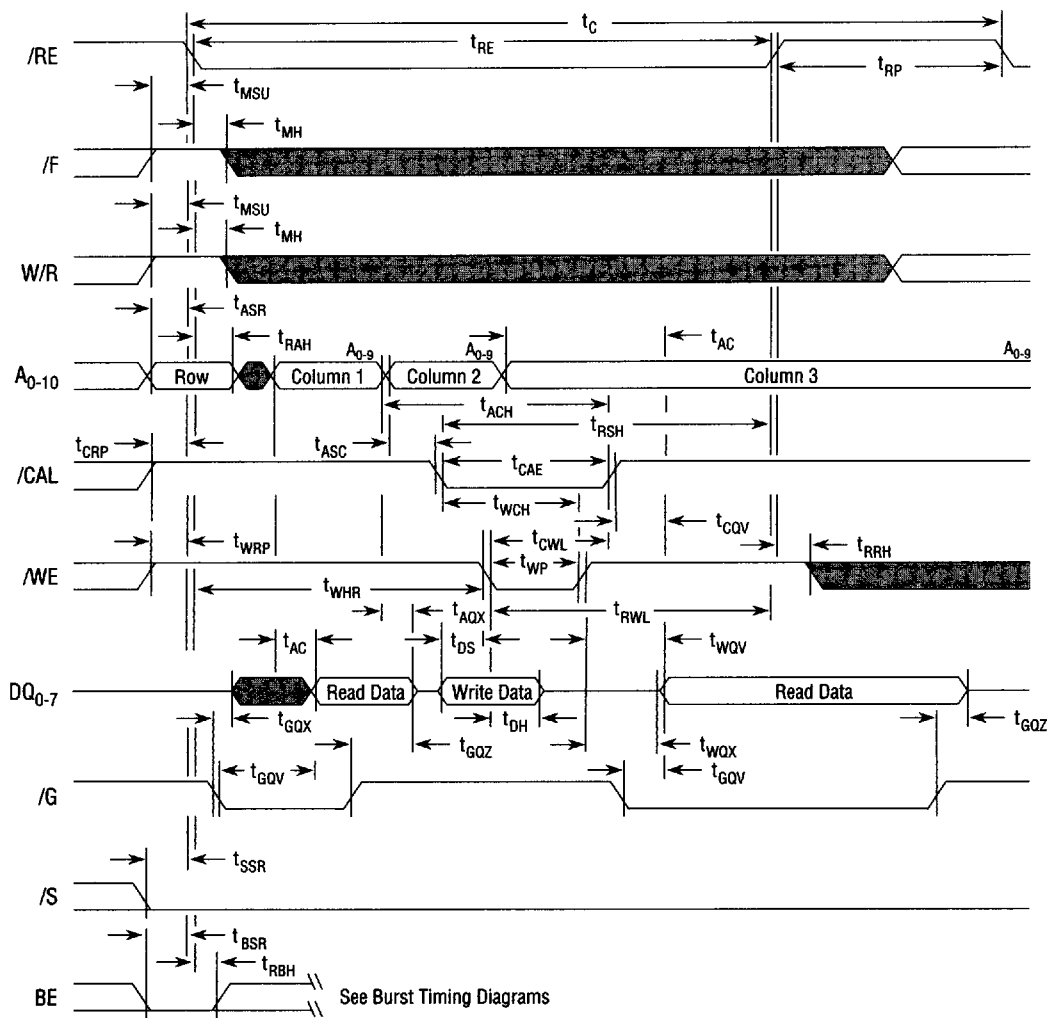

Don't Care or Indeterminate

- NOTES: 1. If column address one equals column address two, then a read-modify-write cycle is performed.
 2. Reads and writes can occur to different banks.

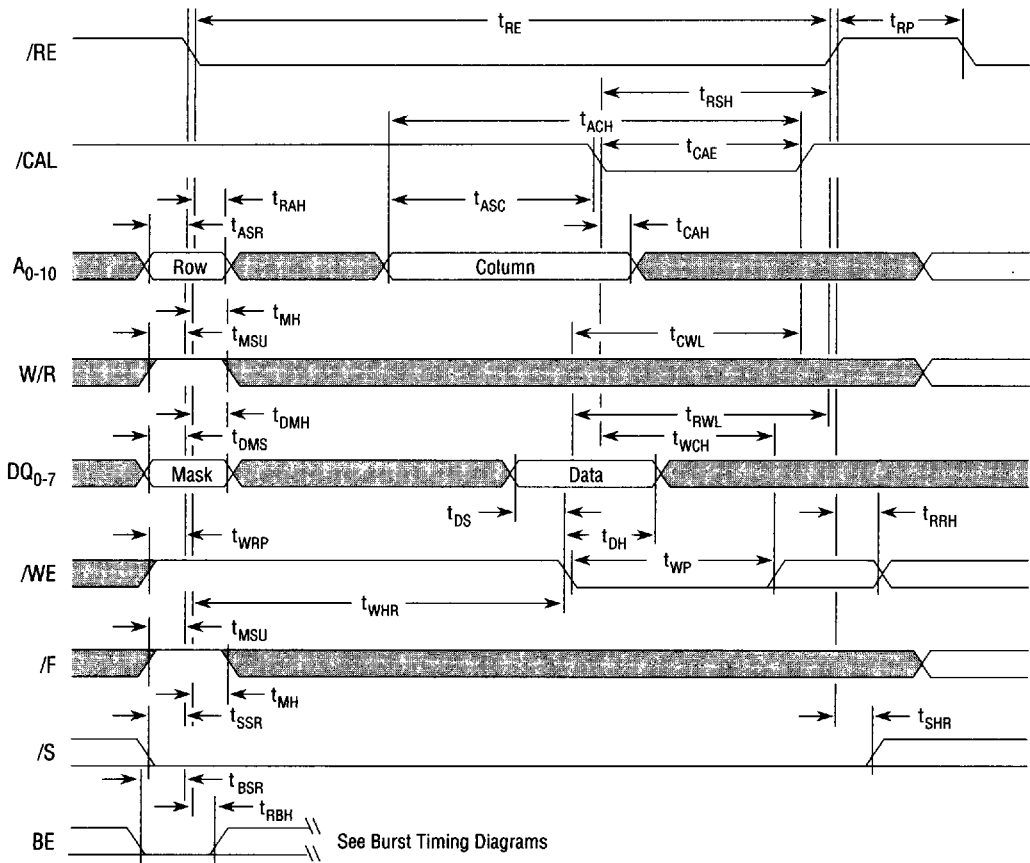
Write-Per-Bit Cycle (/G=High)

Don't Care or Indeterminate

- NOTES: 1. Data mask bit high (1) enables bit write; data mask bit low (0) inhibits bit write.
 2. Write-per-bit cycle only valid for DM2233.

Hidden /F Refresh Cycle During Page Mode and Static Column Cache Reads

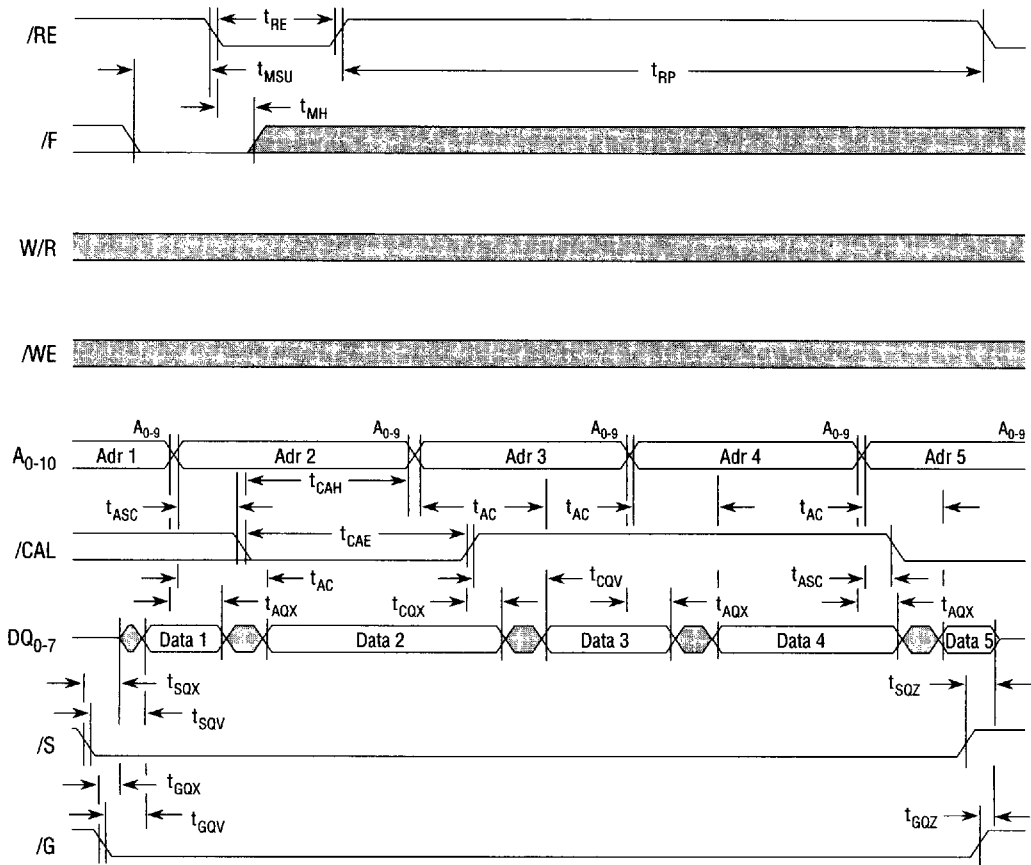

Don't Care or Indeterminate 

- NOTES: 1. During /F refresh cycles, /S is a don't care unless cache reads are performed. For cache reads, /S must be low.
2. Column address $A_{8,9}$ specify cache bank accessed on each read.

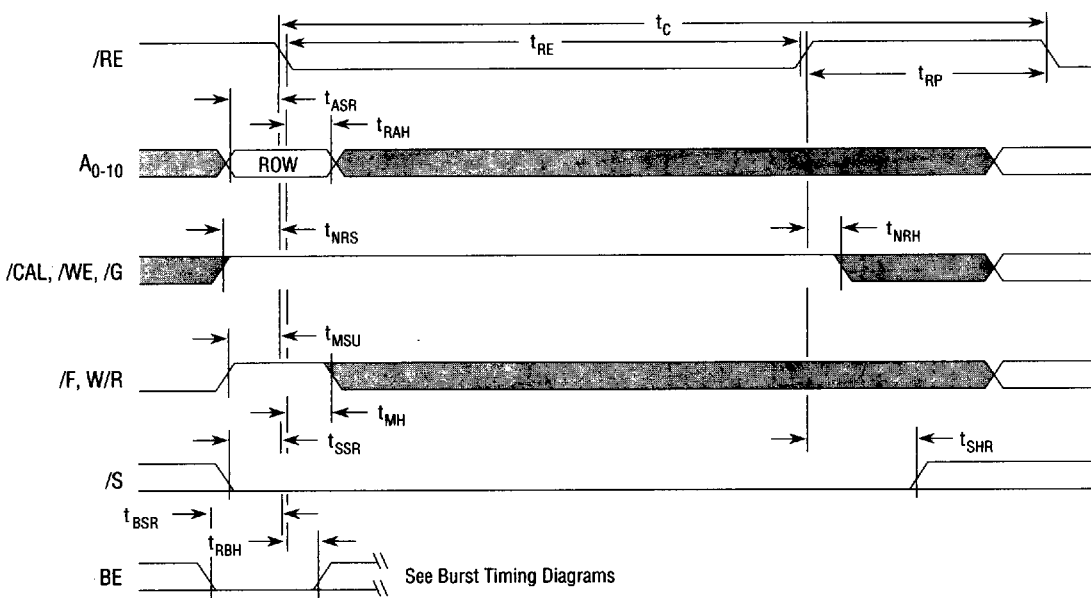
/RE-Only RefreshDon't Care or Indeterminate 

- NOTES: 1. All binary combinations of $A_{0,9}$ must be refreshed every 64ms interval. A_{10} does not have to be cycled, but must remain valid during row address setup and hold times.
2. /RE refresh is write cycle with no /CAL active cycle.

Mechanical Data

44 Pin 300 Mil Plastic TSOP Package

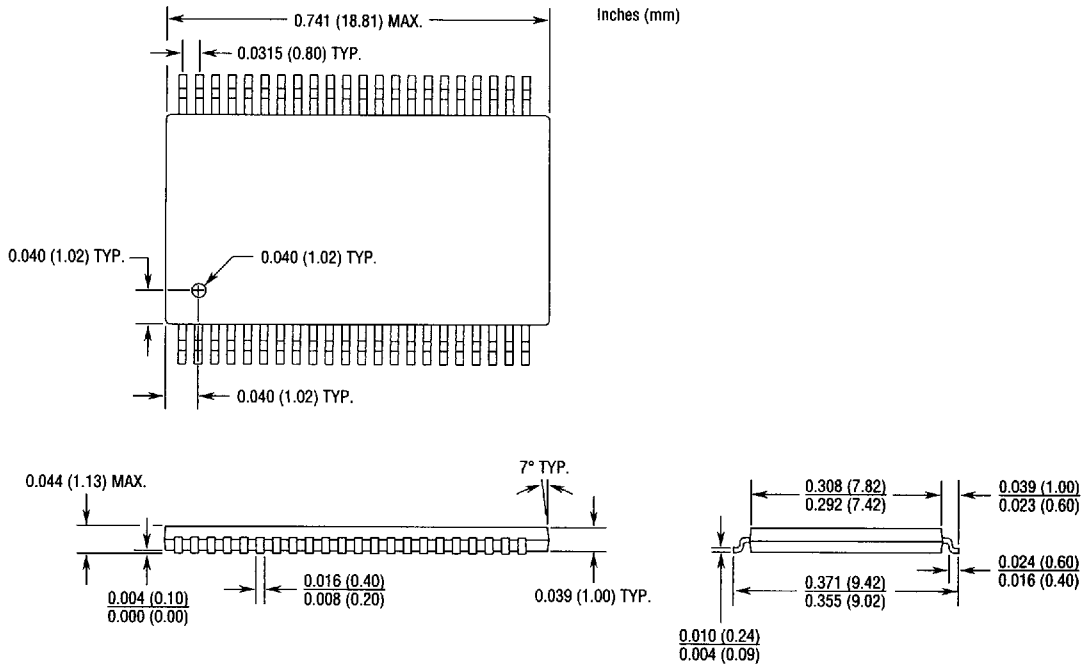

Part Numbering System

DM2223T - 15

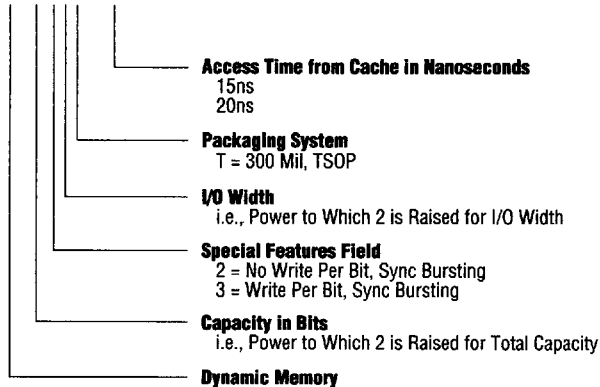

2

The information contained herein is subject to change without notice. Ramtron International Corporation assumes no responsibility for the use of any circuitry other than circuitry embodied in a Ramtron product, nor does it convey or imply any license under patent or other rights.