

Introduces

M210x Series LVPECL/LVDS/CML Clock Oscillator

Featuring **QiK Chip™** Technology

Features:

- Superior Jitter Performance (less than 0.25 ps RMS, 12 kHz - 20 MHz)
- Frequencies from 50 MHz to 1.4 GHz
- Designed for a short 2 week cycle time

Applications:

- Telecommunications such as SONET / SDH / DWDM / FEC / SERDES / OC-3 thru OC-192
- Wireless base stations / WLAN / Gigabit Ethernet
- Avionic flight controls and military communications

MtronPTI
Corporate Headquarters
100 Douglas Avenue
PO Box 630
Yankton, SD 57078-0630
1-800-762-8800
www.mtronpti.com

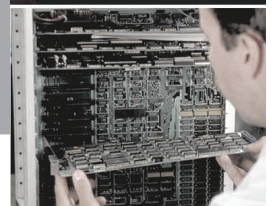
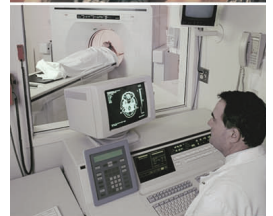

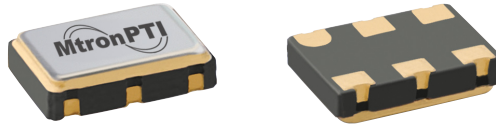

Applications Note:

The MtronPTI M210x series of clock oscillators, featuring *QiK Chip™* technology, provides for extremely low jitter of 0.30 ps RMS. For applications requiring low jitter, frequencies from 150 MHz to 1.4 GHz are available. LVPECL, LVDS, or CML compatible outputs, as well as operating voltage of 1.8 V, 2.5 V, and 3.3 V are also options on the M210x.

The M210x is available at a stability of ± 20 ppm, all-inclusive, over the industrial operating temperature range of -40°C to $+85^{\circ}\text{C}$. By providing this specification, the M210x will perform at a much superior level than SAW based oscillator designs (Figure 1). This level of performance is achieved by utilizing a precision AT-cut crystal. An enable/disable function is also an available option on the M210x. The internal $0.01\ \mu\text{F}$ by-pass capacitor also assures optimum noise suppression on the supply voltage pad.

The superior integrated jitter performance of 0.3 pS RMS makes the M210x suitable for 10 Gig-E, broadband networks, network switches, SONET, SDH, SERDES, DWDM, FEC, WLAN, and OC-3 thru OC-192 systems. The M210x is available in a six-pad or nine-pad, $5 \times 7 \times 1.9$ mm, leadless, ceramic, surface mount package (see page 4) that is RoHS and 260°C reflow compatible. (No PCB traces should be located directly under the 5×7 product). The M210x oscillators offer a pin 1 tristate for backward compatibility to many of the existing products in the industry from Vectron, Epson, and others.

For superior performance in a high frequency clock oscillator, the M210x is a logical choice for designers. The unique design architecture allows the M210x fast turn around on engineering design samples, as well as production quantities in 2 weeks or less.

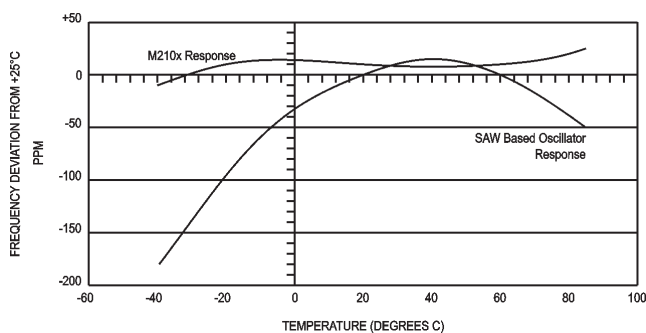

Figure 1. Frequency/Temperature Curves, M210x vs. SAW Based Oscillator Devices

M210x Series LVPECL/LVDS/CML Clock Oscillator – 3.3/2.5/1.8 Volt – 5x7 mm

Product Features

- Featuring **QiK Chip™** Technology
- From order to ship in 2 weeks
- Superior Jitter Performance (less than 0.25 ps RMS, 12 kHz - 20 MHz)
- SAW replacement - better performance
- Frequencies from 50 MHz to 1.4 GHz

Product Description

The 210x series of oscillators are 5x7 mm oscillators designed with the QiK Chip™ technology. The QiK Chip™ technology was specifically designed for crystal based oscillators to provide low jitter performance (as low as 0.25 ps RMS) and a wide range of frequency support (150.00 MHz to 1.4 GHz) and provides a breakthrough in lean manufacturing enabling product to be provided in less than 2 weeks. The M210x provides design engineers with the stability needed in their advanced applications and supports the need for parts to be supplied quickly so that the rest of their circuit design can be solidified.

Product Applications

- Telecommunications such as SONET / SDH / DWDM / FEC / SERDES / OC-3 thru OC-192
- 1-2-4-10 Gigabit Fibre Channel
- Wireless Base Stations / WLAN / Gigabit Ethernet
- Avionic Flight Controls
- Military Communications
- Clock and Data Recovery
- SD/HD Video
- FPGA/ASIC Clock Generation
- Test and Measurement Equipment

Product Ordering Information

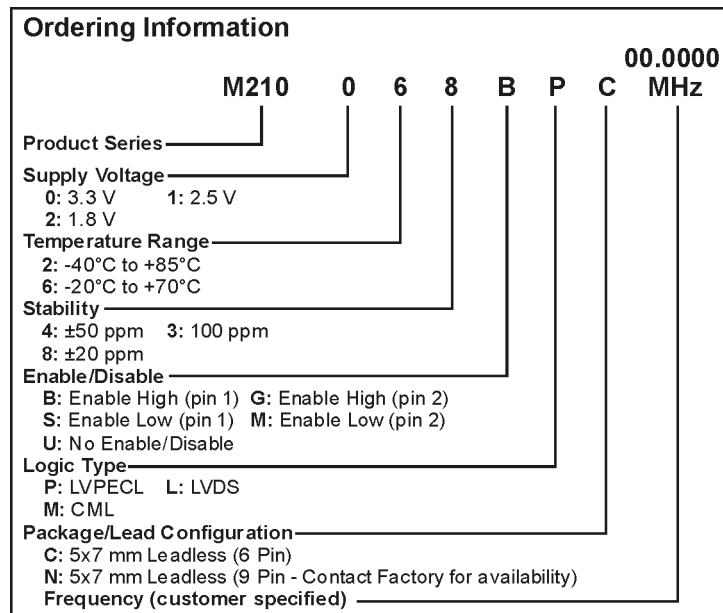

M2100Sxxx, M2101Sxxx, M2102Sxxx & M2103Sxxx -
Contact factory for datasheets.

MtronPTI reserves the right to make changes to the product(s) and service(s) described herein without notice. No liability is assumed as a result of their use or application.

Please see www.mtronpti.com for our complete offering and detailed datasheets. Contact us for your application specific requirements: MtronPTI 1-800-762-8800.

Performance Characteristics

PARAMETER	Symbol	Min.	Typ.	Max.	Units	Condition/Notes
Frequency Range	F	50		1400	MHz	See Note 1
Operating Temperature	T _A	(See ordering information)				
Storage Temperature	T _S	-55		+125	°C	
Frequency Stability	ΔF/F	(See ordering information)				
Aging 1st Year Thereafter (per year)		-3 -1		+3 +1	ppm ppm	
Supply Voltage	V _{cc}	1.71 2.375 3.135	1.8 2.5 3.3	1.89 2.625 3.465	V V V	LVDS/CML
Input Current	I _{cc}			125	mA	LVPECL/LVDS/CML
Load		50 Ohms to (V _{cc} -2) V _{dc} 100 Ohm differential load				See Note 3 LVPECL Waveform LVDS/CML Waveform
Symmetry (Duty Cycle)		45		55	%	LVPECL – V _{dd} -1.3 V LVDS – 1.25 V
Output Skew			20 15 20		ps ps ps	LVPECL CML LVDS
Differential Voltage	V _{od}	250	350	450	mV	LVDS
	V _{od}	0.7	.095	1.20	V _{pp}	CML
Common Mode Output Voltage	V _{cm}		1.2		V	LVDS
Logic “1” Level	V _{oh}	V _{cc} -1.02			V	LVPECL
Logic “0” Level	V _{ol}			V _{cc} -1.63	V	LVPECL
Rise/Fall Time	T _r /T _f		0.23	0.50	ns	@ 20/80% LVPECL, LVDS, CML
Enable Function		80% V _{cc} min or N/C: Output active 0.5V max: Output disables to high-Z				Output Option B or G
		0.5V max or N/C: Output active 80% V _{cc} min: Output disables to high-Z				Output Option S or M
Start up Time				10	ms	
Phase Jitter @ 622.08 MHz	φ _J		0.25		ps RMS	Integrated 12 kHz – 20 MHz
Phase Noise 10 Hz 100 Hz 1 KHz 10 KHz 100 KHz 1 MHz 10 MHz 100 MHz			-60 -97 -107 -116 -121 -134 -146 -148			@ 622.08 MHz dBc/Hz dBc/Hz dBc/Hz dBc/Hz dBc/Hz dBc/Hz dBc/Hz dBc/Hz
Mechanical Shock	Per MIL-STD-202, Method 213, Condition C (100 g's, 6 ms duration, ½ sinewave)					
Vibration	Per MIL-STD-202, Method 201 & 204 (10 g's from 10-2000 Hz)					
Hermeticity	Per MIL-STD-202, Method 112, (1x10 ⁻⁸ atm. cc/s of Helium)					
Thermal Cycle	Per MIL-STD-883, Method 1010, Condition B (-55°C to +125°C, 15 min. dwell, 10 cycles)					
Solderability	Per EIAJ-STD-002					
Max Soldering Conditions	See solder profile, Figure 1					

Note 1: Contact factory for standard frequency availability over 945 MHz

Note 2: Stability is inclusive of initial tolerance, deviation over temperature, shock, vibration, supply voltage, and aging for one year at 50°C mean ambient temperature.

Note 3: See Load Circuit Diagram in this Datasheet. Consult factory with nonstandard output load requirements.

Phase Noise Plot

M210X Phase Noise Plot @ 622.08 MHz

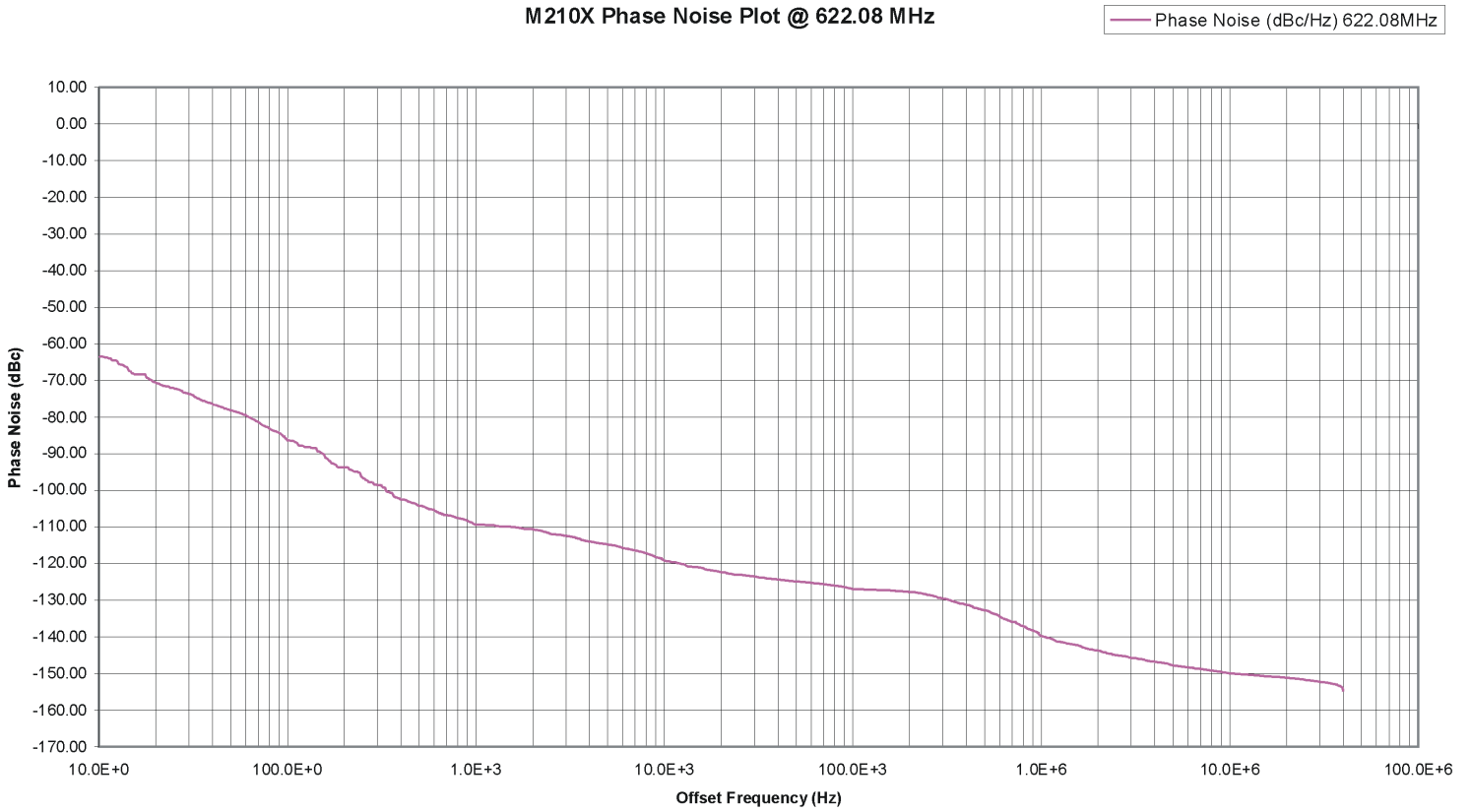

Output Waveform

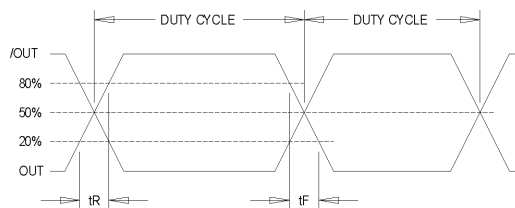

Output Waveform: LVDS/CML/PECL

MtronPTI reserves the right to make changes to the product(s) and service(s) described herein without notice. No liability is assumed as a result of their use or application.

Please see www.mtronpti.com for our complete offering and detailed datasheets. Contact us for your application specific requirements: MtronPTI 1-800-762-8800.

Product Dimension & Pinout Information

6 Pad Standard Option

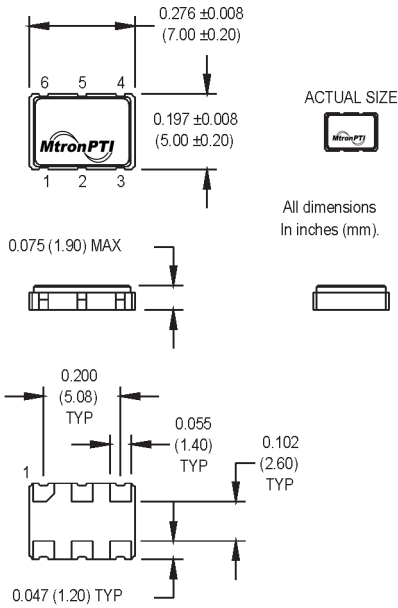

PIN 1 ENABLE

- Pad1: Enable/Disable
- Pad2: N/C
- Pad3: Ground
- Pad4: Output Q (LVPECL, LVDS, CML)
- Pad5: Output Q̄ (LVPECL, LVDS, CML)
- Pad6: Vcc

PIN 2 ENABLE

- Pad1: N/C
- Pad2: Enable/Disable
- Pad3: Ground
- Pad4: Output Q (LVPECL, LVDS, CML)
- Pad5: Output Q̄ (LVPECL, LVDS, CML)
- Pad6: Vcc

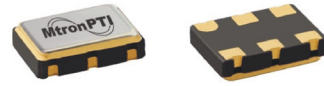

SUGGESTED SOLDER PAD LAYOUT

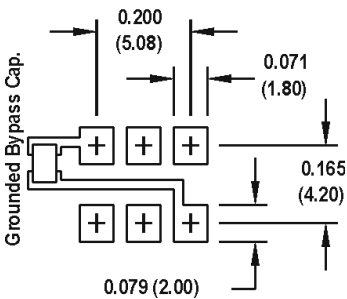

9 Pad Option

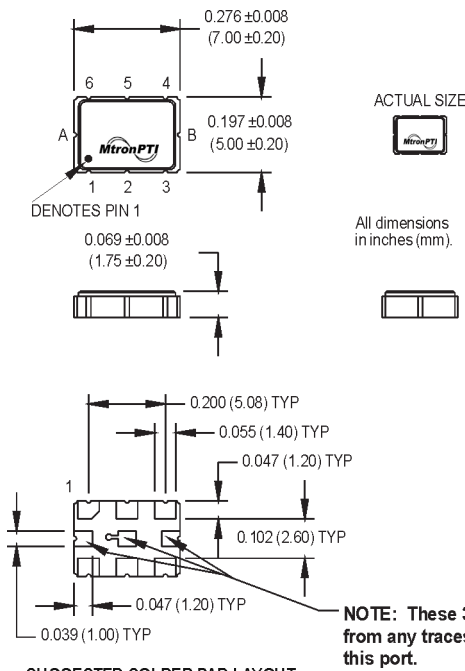

PIN 1 ENABLE

- Pad1: Enable/Disable
- Pad2: N/C
- Pad3: Ground
- Pad4: Output Q (LVPECL, LVDS, CML)
- Pad5: Output Q̄ (LVPECL, LVDS, CML)
- Pad6: Vcc
- PadA: Do not connect!
- PadB: Do not connect!
- PadC: Do not connect!

PIN 2 ENABLE

- Pad1: N/C
- Pad2: Enable/Disable
- Pad3: Ground
- Pad4: Output Q (LVPECL, LVDS, CML)
- Pad5: Output Q̄ (LVPECL, LVDS, CML)
- Pad6: Vcc
- PadA: Do not connect!
- PadB: Do not connect!
- PadC: Do not connect!

SUGGESTED SOLDER PAD LAYOUT

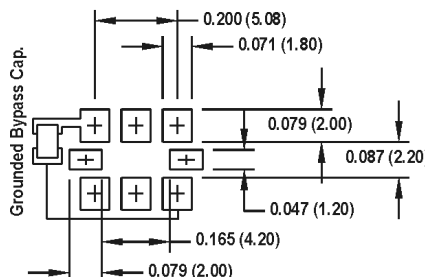

MtronPTI reserves the right to make changes to the product(s) and service(s) described herein without notice. No liability is assumed as a result of their use or application.

Please see www.mtronpti.com for our complete offering and detailed datasheets. Contact us for your application specific requirements: MtronPTI 1-800-762-8800.

Handling Information

Although protection circuitry has been designed into the M210x oscillator, proper precautions should be taken to avoid exposure to electrostatic discharge (ESD) during handling and mounting. MtronPTI utilizes a human-body model (HBM) and a charged-device model (CDM) for ESD-susceptibility testing and protection design evaluation. ESD voltage thresholds are dependent on the circuit parameters used to define the mode. Although no industry-wide standard has been adopted for the CDM, a standard HBM (resistance = 1500 Ω, capacitance = 100 pF) is widely used and therefore can be used for comparison purposes. The HBM ESD threshold presented here was obtained using these circuit parameters.

Model	ESD Threshold, Minimum	Unit
Human Body	1500*	V
Charged Device	1500*	V

* MIL-STD-883D, Method 3015, Class 1



Quality Parameters

Environmental Specifications/Qualification Testing Performed on the M210 Clock Oscillator		
Test	Test Method	Test Condition
Electrical Characteristics	Internal Specification	Per Specification
Frequency vs. Temperature	Internal Specification	Per Specification
Mechanical Shock	MIL-STD-202, Method 213, C	100 g's
Vibration	MIL-STD-202, Method 201-204	10 g's from 10-2000 Hz
Thermal Cycle	MIL-STD-883, Method 1010, B	-55 Deg. C to +125 Deg. C, 15 minute Dwell, 10 cycles
Aging	Internal Specification	168 Hours at 105 Degrees C
Gross Leak	MIL-STD-202, Method 112	30 Second Immersion
Fine Leak	MIL-STD-202, Method 112	Must meet 1x10 ⁻⁸
Solderability	MIL-STD-883, Method 2003	8 Hour Steam Age – Must Exhibit 95% coverage
Resistance to Solvents	MIL-STD-883, Method 2015	Three 1 minute soaks
Terminal Pull	MIL-STD-883, Method 2004, A	2 Pounds
Lead Bend	MIL-STD-883, Method 2004, B1	1 Bending Cycle
Physical Dimensions	MIL-STD-883, Method 2016	Per Specification
Internal Visual	Internal Specification	Per Internal Specification

Part Marking Guide

- Line 1: Model Number
- Line 2: Frequency
- Line 3: Date Code
- Line 4: Pin 1 Indicator / MtronPTI

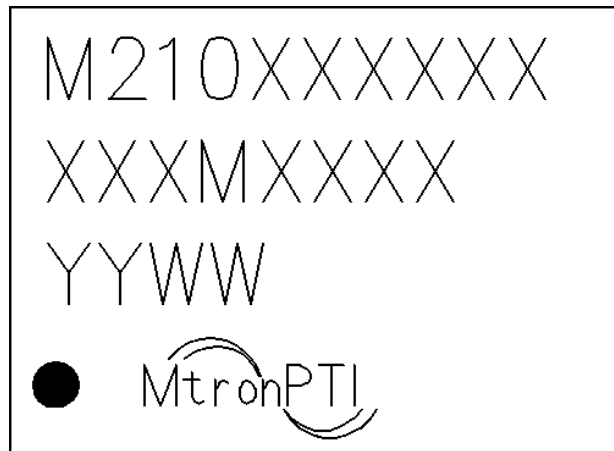

MtronPTI reserves the right to make changes to the product(s) and service(s) described herein without notice. No liability is assumed as a result of their use or application.

M210x Series LVPECL/LVDS/CML Clock Oscillator – 3.3/2.5/1.8 Volt – 5x7 mm

Tape & Reel Specifications

(all measurements are in mm)	A	B	C	D	E	F	G	H	I	J	K	L
M210x	6.51	9.29	1.5	7.5	2.8	4	8/12	16	180-330	13	21	60-100

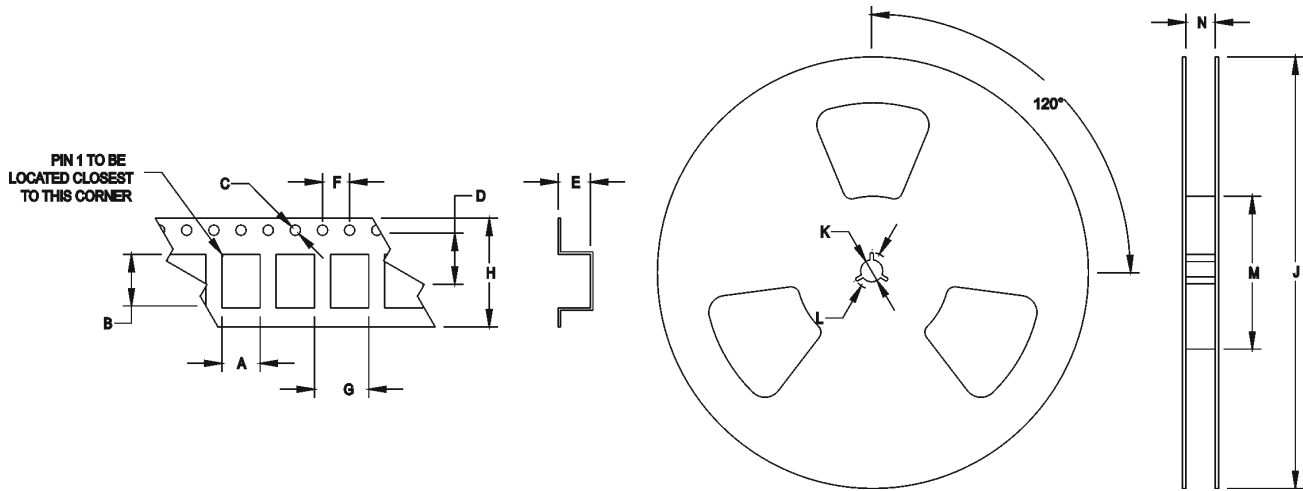

Standard Tape and Reel: 1000 parts per reel

Maximum Soldering Conditions

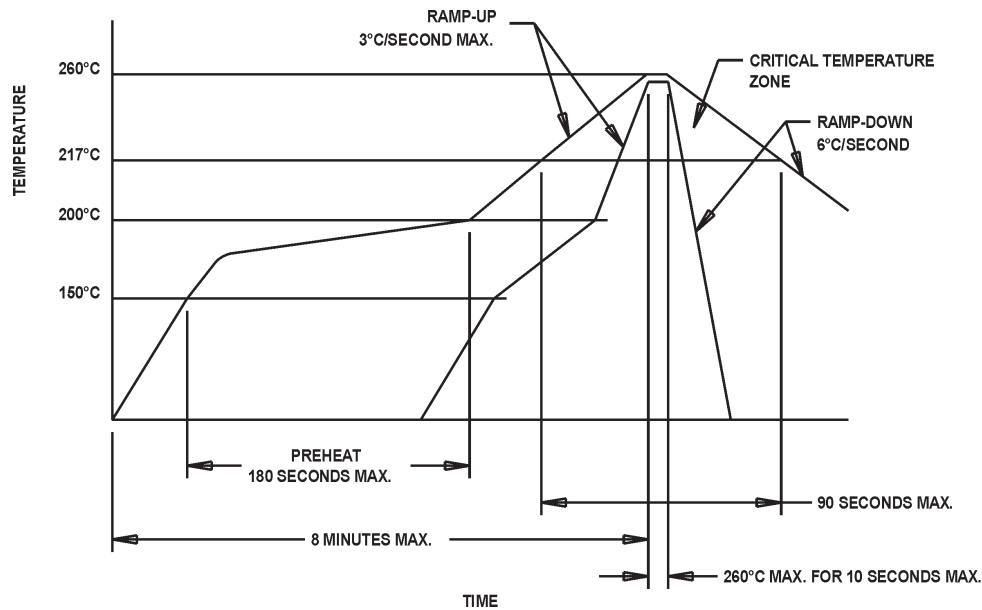

Solder Conditions

Note: Exceeding these limits may damage the device.

MtronPTI reserves the right to make changes to the product(s) and service(s) described herein without notice. No liability is assumed as a result of their use or application.

Please see www.mtronpti.com for our complete offering and detailed datasheets. Contact us for your application specific requirements: MtronPTI 1-800-762-8800.

Typical Test Circuit & Load Circuit Diagrams

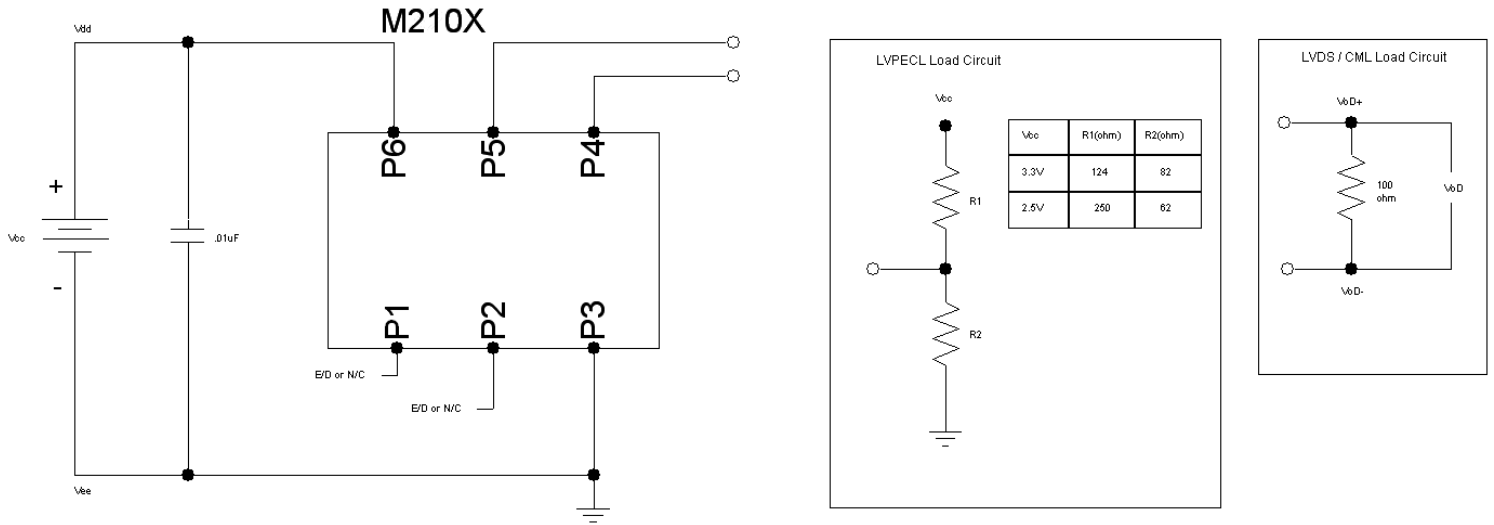

Product Revision Table

Date	Revision	PCN Number	Details of Revision
7/20/07	A	10118	IC Revision to improve phase noise and electrical performance

For custom products or additional specifications contact our sales team at **800.762.8800 (toll free) or 605.665.9321**

For more information on this product visit the MtronPTI website at **www.mtronpti.com**



Yankton

PO Box 630
Yankton, SD 57078-0630 USA
Phone: 605-665-9321
Toll Free: 800-762-8800
Fax: 605-665-1709
Email: SalesYKT@mtronpti.com

Orlando

2525 Shader Rd
Orlando, FL 32804 USA
Phone: 407-298-2000
Fax: 407-293-2979
Email: SalesORL@mtronpti.com

Connecticut

755 Main Street
Suite 2B, Building 2
Monroe, CT 06470 USA
Phone: 800.762.8800
Fax: 203.452.9435
Email: MilSales@mtronpti.com

Santa Clara

1495 Franklin Street
Santa Clara, CA 95050 USA
Phone: 408.395.0700
Fax: 408.395.8074
Email: SalesCA@mtronpti.com

Europe

The Netherlands
Phone: 31-40-368-6818
Fax: 011-31-40-368-3501
Email: SalesEU@mtronpti.com

Asia Pacific

1104 Shanghai Industrial
Investment Building
48-62 Hennessy Road
Wanchai, Hong Kong, China
Phone: 852-2866-8023
Fax: 852-2529-1822
Email: SalesHK@mtronpti.com