

256KB Asynchronous Secondary Cache Module for PowerPC™

The MPC2001 is designed to provide asynchronous 256KB .2 cache for the PowerPC 60x processors. The module is configured as 32K x 64 bits in a 136 pin dual readout single inline memory module (DIMM). The module uses eight of Motorola's MCM6206 CMOS RAMs.

Eight write enables are provided for byte write control.

The cache is designed to interface with the PowerPC 60x bus and requires external tag.

PD0 – PD2 are reserved for density and speed identification

The cache is plug and pin compatible with Motorola's MPC2002 and MPC2003 BurstRAM™ synchronous cache modules.

- Dual Readout SIMM (DIMM) for Circuit Density
- Single 5 V ± 5% Power Supply
- All Inputs and Outputs are TTL Compatible
- Three State Outputs
- Byte Write Capability
- Decoupling Capacitors for each Fast Static RAM
- High Quality Multi-Layer FR4 PWB With Separate Power and Ground Planes
- Fast SRAM Access Times: 12 ns, 15 ns
- Low Cost Asynchronous Solution for MPC105 PCI Bridge/Memory Controller Chip

MPC2001

(Formerly MCM64AC32)

136-LEAD DIMM
CASE 1104-01
TOP VIEW

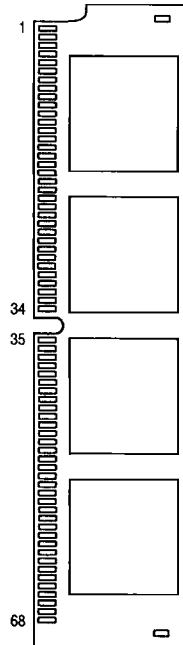

6

BurstRAM is a trademark of Motorola.

PowerPC and PowerPC 601 are trademarks of International Business Machines Corp.

5/95

PIN ASSIGNMENT
136-LEAD DIMM
CASE 1104-01
TOP VIEW

PD2	PD1	PD0	Cache Size	Module
NC	V _{SS}	NC	256KB	MPC2001SG12
NC	V _{SS}	V _{SS}	256KB	MPC2001SG15

6

PIN NAMES	
A0 – A14	Address Inputs
W0 – W7	Byte Write
E0, E1	Module Enable
G0, G1	Module Output Enable
DQ0 – DQ63	Cache Data Input/Output
PD0 – PD2	Presence Detect
V _{CC}	+ 5 V Power Supply
ALE	Address Latch Enable
V _{SS}	Ground
NC	No Connection

PD0	1	69	V _{SS}
PD1	2	70	PD2
DQ0	3	71	V _{CC}
DQ1	4	72	DQ2
V _{CC}	5	73	DQ3
DQ4	6	74	DQ5
DQ6	7	75	DQ7
NC	8	76	V _{SS}
DQ8	9	77	DQ9
DQ10	10	78	DQ11
V _{SS}	11	79	DQ12
NC	12	80	V _{SS}
V _{SS}	13	81	DQ13
DQ14	14	82	DQ15
V _{CC}	15	83	NC
DQ16	16	84	V _{SS}
DQ17	17	85	DQ18
DQ19	18	86	DQ20
DQ21	19	87	DQ22
V _{CC}	20	88	DQ23
NC	21	89	V _{SS}
DQ24	22	90	DQ25
DQ26	23	91	DQ27
DQ28	24	92	DQ29
V _{SS}	25	93	DQ30
DQ31	26	94	V _{SS}
NC	27	95	E0
V _{SS}	28	96	W1
W0	29	97	W3
W2	30	98	G0
NC	31	99	NC
NC	32	100	V _{SS}
V _{CC}	33	101	G1
W4	34	102	W5
W6	35	103	W7
DQ32	36	104	E1
DQ33	37	105	DQ34
V _{SS}	38	106	DQ35
DQ36	39	107	DQ37
DQ38	40	108	V _{CC}
DQ39	41	109	NC
DQ40	42	110	DQ41
V _{CC}	43	111	DQ42
DQ43	44	112	DQ44
DQ45	45	113	V _{SS}
DQ46	46	114	DQ47
NC	47	115	DQ48
V _{SS}	48	116	DQ49
NC	49	117	V _{SS}
V _{SS}	50	118	DQ50
DQ52	51	119	DQ51
DQ53	52	120	DQ54
DQ55	53	121	DQ56
NC	54	122	V _{SS}
V _{CC}	55	123	DQ57
DQ58	56	124	DQ59
DQ60	57	125	DQ61
DQ62	58	126	DQ63
NC	59	127	V _{CC}
A0	60	128	A1
A2	61	129	A3
A4	62	130	A5
A6	63	131	A7
A8	64	132	ALE
A10	65	133	A9
A12	66	134	A11
A14	67	135	A13
V _{SS}	68	136	NC

MPC2001 BLOCK DIAGRAM
Asynchronous 136 Pin DIMM

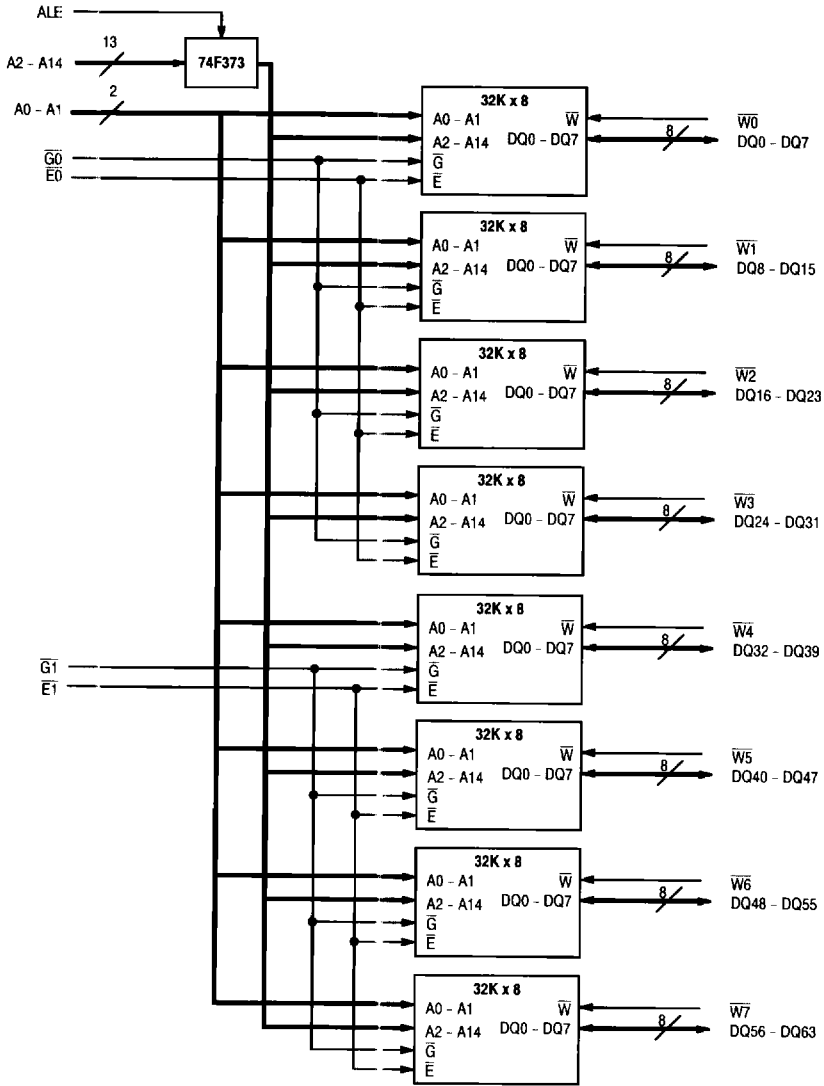

ORDERING INFORMATION
(Order by Full Part Number)

Motorola Memory Prefix	MPC	2001	XX	XX	Speed (12 = 12 ns, 15 = 15 ns)
Part Number					Package (SG = Gold Pad SIMM)

Full Part Numbers — MPC200 SG12 MPC2001SG15