



M.S.KENNEDY CORP.

600V/600A HALF BRIDGE PEM

4803

4707 Dey Road Liverpool, N.Y. 13088

(315) 701-6751

FEATURES:

- Half Bridge Configuration
- 600V Rated Voltage
- 600A Continuous Output Current
- Internal Zener Clamps on Gates
- Proprietary Encapsulation Provides Near Hermetic Performance
- MIL-PRF-38534 Screening Available (Modified)
- Light Weight Domed ALSIC Baseplate
- Robust Mechanical Design for Hi-Rel Applications
- Ultra-Low Inductance Internal Layout
- Withstands 96 Hours HAST and Thermal Cycling (-55°C to +125°C)
- High Side Collector Sense Pin for De-Sat Detection

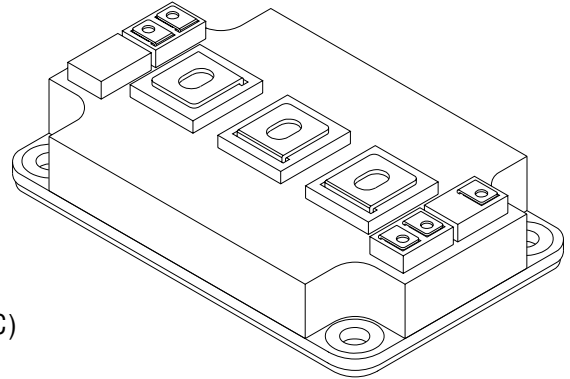

DESCRIPTION:

The MSK 4803 is one of a family of plastic encapsulated modules (PEM) developed specifically for use in military, aerospace and other severe environment applications. The half bridge configuration and 600 volt/600 amp rating make it ideal for use in high current motor drive and inverter applications. The Aluminum Silicon Carbide (AlSiC) baseplate offers superior flatness and light weight; far better than the copper or copper alloys found in most high power plastic modules. The high thermal conductivity materials used to construct the MSK 4803 allow high power outputs at elevated baseplate temperatures. Our proprietary coating, SEES™ - Severe Environment Encapsulation System - protects the internal circuitry of MSK PEM's from moisture and contamination, allowing them to pass the rugged environmental screening requirements of military and aerospace applications. MSK PEM's are also available with industry standard silicone gel coatings for a lower cost option.

EQUIVALENT SCHEMATIC

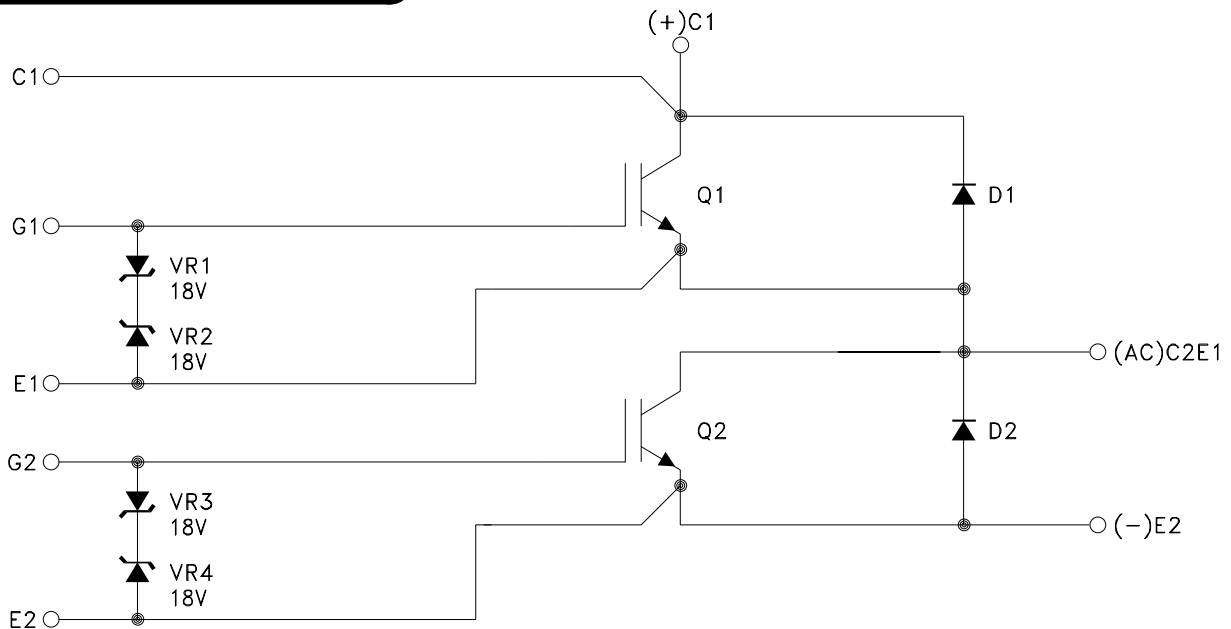

TYPICAL APPLICATIONS

- Motor Drives
- Inverters

ABSOLUTE MAXIMUM RATING ^⑧

V _{CE}	Collector to Emitter Voltage	600V
V _{GE}	Gate to Emitter Voltage	± 20V
I _{OUT}	Current (Continuous)	600A
I _{OUTP}	Current Pulsed (1mS)	1200A
V _{CASE}	Case Isolation Voltage	2500 V

T _{ST}	Storage Temperature Range	-55°C to +125°C
T _J	Junction Temperature	150°C
T _C	Case Operating Temperature Range	
	MSK 4803H/E	-55°C to +125°C
	MSK 4803	-40°C to +85°C

ELECTRICAL SPECIFICATIONS

Parameter ^⑥	Test Conditions	Group A Subgroup	MSK 4803 H/E			MSK 4803			Units
			Min.	Typ.	Max.	Min.	Typ.	Max.	
Collector-Emitter Saturation Voltage	I _C = 600A, V _{GE} = 15V	1	-	2.55	2.9	-	2.55	3.0	V
		2	-	2.90	3.2	-	-	-	V
		3	-	3.60	4.0	-	-	-	V
Collector-Emitter Leakage Current	V _{CE} = 600V, V _{GE} = 0V	1	-	0.5	1000	-	0.5	1000	uA
		2	-	500	5000	-	-	-	uA
Gate Threshold Voltage	I _C = 60mA, V _{CE} = V _{GE}	1	3.5	4.1	7.5	3.3	4.1	7.8	V
		2	3.0	3.5	7.5	-	-	-	V
		3	4.0	4.5	8.5	-	-	-	V
Gate Leakage Current	V _{CE} = 0V, V _{GE} = ± 15V	1	-	0.1	10	-	0.1	10	uA
		2	-	0.6	10	-	-	-	uA
		3	-	0.1	10	-	-	-	uA
Diode Forward Voltage	I _C = 600A	1	-	1.8	2.5	-	1.8	2.6	V
		2	-	1.8	2.5	-	-	-	V
		3	-	2.0	2.8	-	-	-	V
Total Gate Charge ^①	V = 300V, I _C = 600A	4	-	3.2	4.5	-	3.2	4.8	uC
E(on) ^①	V = 300V, I _C = 600A, R _G = 5Ω, V _{GE} = -7/+15V	4	-	17.5	-	-	17.5	-	mJ
	V = 300V, I _C = 300A, R _G = 5Ω, V _{GE} = -7/+15V	4	-	10	15	-	10	18	mJ
	V = 300V, I _C = 600A, R _G = 5Ω, V _{GE} = -7/+15V	5	-	22	-	-	-	-	mJ
	V = 300V, I _C = 300A, R _G = 5Ω, V _{GE} = -7/+15V	5	-	12	-	-	-	-	mJ
E(off) ^①	V = 300V, I _C = 600A, R _G = 10Ω, V _{GE} = -7/+15V	4	-	60	-	-	60	-	mJ
	V = 300V, I _C = 300A, R _G = 10Ω, V _{GE} = -7/+15V	4	-	26	35	-	26	38	mJ
	V = 300V, I _C = 600A, R _G = 10Ω, V _{GE} = -7/+15V	5	-	64	-	-	-	-	mJ
	V = 300V, I _C = 300A, R _G = 10Ω, V _{GE} = -7/+15V	5	-	30	-	-	-	-	mJ
Diode Reverse Recovery Time ^①	I _E = 600, di/dt = 3500A/uS	4	-	190	-	-	190	-	nS
	I _E = 300, di/dt = 3500A/uS	4	-	185	-	-	185	-	nS
	I _E = 600, di/dt = 3500A/uS	5	-	270	-	-	-	-	nS
	I _E = 300, di/dt = 3500A/uS	5	-	250	-	-	-	-	nS
Diode Reverse Energy ^①	I _E = 600, di/dt = 3500A/uS	4	-	7.5	-	-	7.5	-	mJ
	I _E = 300, di/dt = 3500A/uS	4	-	6	8	-	6	-	mJ
	I _E = 600, di/dt = 3500A/uS	5	-	16	-	-	-	-	mJ
	I _E = 300, di/dt = 3500A/uS	5	-	24	-	-	-	-	mJ
Thermal Resistance ^①	IGBT @ T _J = 125°C	-	-	0.05	0.07	-	0.05	0.07	°C/W
	DIODE @ T _J = 125°C	-	-	0.09	0.11	-	0.09	0.11	°C/W

NOTES:

- ① Guaranteed by design but not tested. Typical parameters are representative of actual device performance but are for reference only.
- ② Industrial grade and "E" suffix devices shall be tested to subgroup 1 unless otherwise specified.
- ③ Military grade devices ("H" suffix) shall be 100% tested to subgroups 1, 2 and sample tested to subgroup 3.
- ④ Subgroups 4 testing available upon request.
- ⑤ Subgroup 1, 4 T_A = +25°C
2, 5 T_A = +125°C
3 T_A = -55°C
- ⑥ All specifications apply to both the upper and lower sections of the half bridge.
- ⑦ V_{GE} = 15V unless otherwise specified.
- ⑧ Continuous operation at or above absolute maximum ratings may adversely effect the device performance and/or life cycle

THERMAL CALCULATIONS

Power dissipation and maximum allowable temperature rise involve many variables working together. Collector current, PWM duty cycle and switching frequency all factor into power dissipation. DC losses or "ON-TIME" losses are simply $V_{CE(SAT)} \times \text{Collector Current} \times \text{PWM duty cycle}$. For the MSK 4803, $V_{CE(SAT)} = 2.9V$ max., and at 600 amps and a PWM duty cycle of 30%, DC losses equal 522 watts. Switching losses vary proportionally with switching frequency. The MSK 4803 typical switching losses at $V_{CE} = 300V$ and $I_{CE} = 600A$ are about 78mJ, which is simply the sum of the turn-on switching loss and the turn-off switching loss. Multiplying the switching frequency times the switching losses will result in a power dissipation number for switching. The MSK 4803, at 5KHz, will exhibit switching power dissipation of 390 watts. The total losses are the sum of DC losses plus switching losses, or in this case, 912 watts total.

912 watts \times 0.07 °C/W thermal resistance equals 64 degrees of temperature rise between the case and the junction. Subtracting 64 °C from the maximum junction temperature of 150 °C equals 86 °C maximum case temperature for this example.

$$V_{CE(SAT)} \times I_C \times \text{PWM duty cycle} = 2.9V \times 600 \text{ amps} \times 30\% = 522 \text{ watts DC losses}$$

$$\text{Turn-on switching loss} + \text{Turn-off switching loss} = \text{Total switching losses} = 17.5 + 60 = 77.5\text{mJ}$$

$$\text{Total switching loss} \times \text{PWM frequency} = \text{Total switching power dissipation} = 78\text{mJ} \times 5\text{KHz} = 390 \text{ watts}$$

$$\text{Total power dissipation} = \text{DC losses} + \text{switching losses} = 522 + 390 = 912 \text{ watts}$$

$$\text{Junction temperature rise above case} = \text{Total power dissipation} \times \text{thermal resistance}$$

$$912 \text{ watts} \times 0.07 \text{ °C/W} = 63.8 \text{ °C temperature rise above case}$$

$$\text{Maximum junction temperature} - \text{junction temperature rise} = \text{maximum baseplate temperature}$$

$$150 \text{ °C} - 64 \text{ °C} = 86 \text{ °C}$$

TYPICAL PERFORMANCE CURVES

TYPICAL OUTPUT CHARACTERISTICS

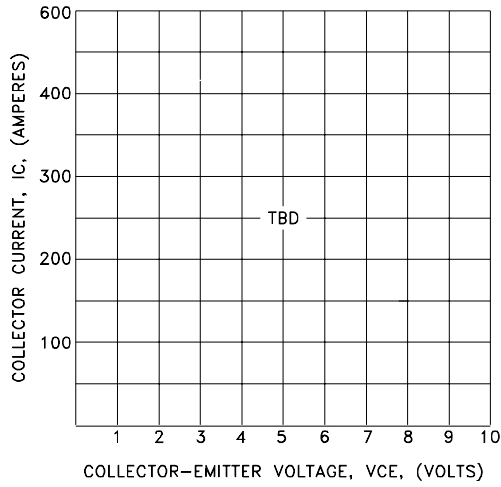

COLLECTOR-EMITTER SATURATION VOLTAGE CHARACTERISTICS

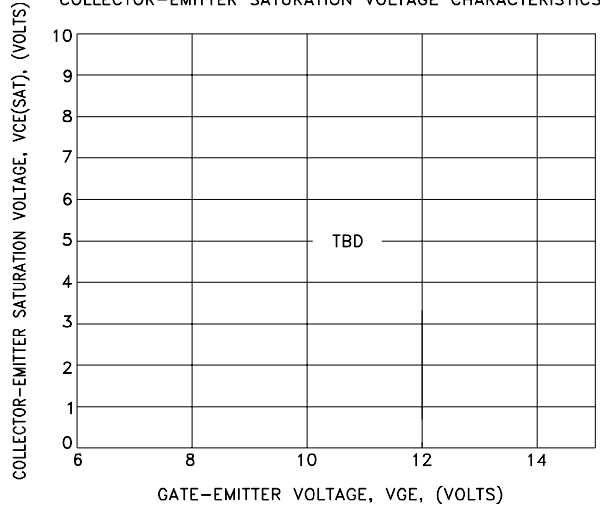

FREE-WHEEL DIODE FORWARD CHARACTERISTICS

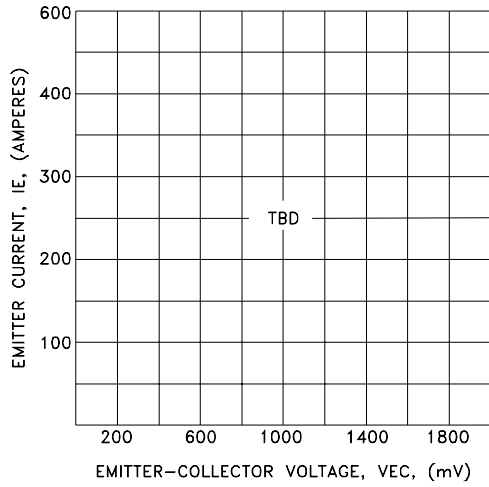

SWITCHING CHARACTERISTICS

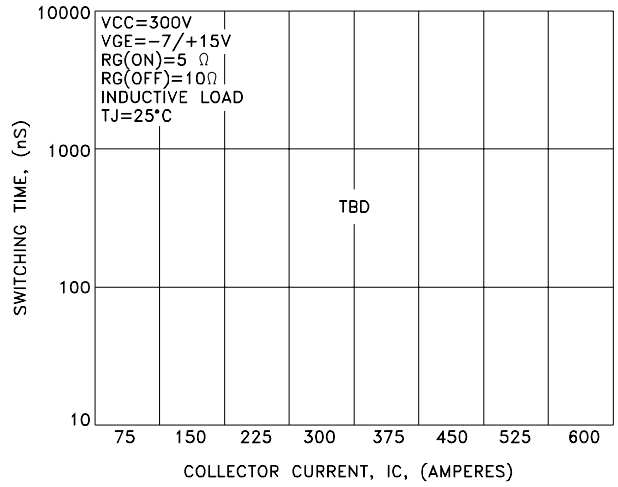

REVERSE RECOVERY CHARACTERISTICS

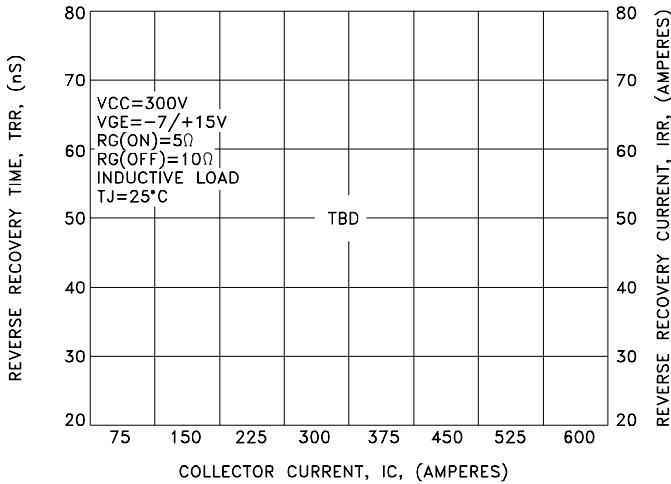

SWITCHING LOSS vs. COLLECTOR CURRENT

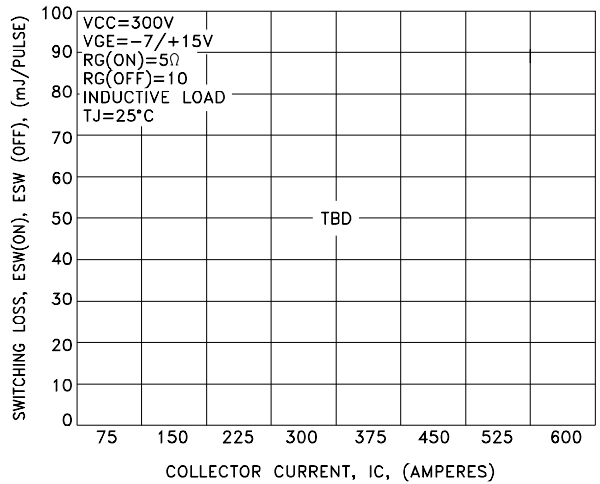

SCREENING CHART

OPERATION IN ACCORDANCE WITH MIL-PRF-38534	INDUSTRIAL	CLASS E	CLASS H
QUALIFICATION (MODIFIED)	NO	NO	YES
ELEMENT EVALUATION	NO	YES	YES
CLEAN ROOM PROCESSING	YES	YES	YES
NON DESTRUCT BOND PULL SAMPLE	YES	YES	YES
CERTIFIED OPERATORS	NO	YES	YES
MIL LINE PROCESSING	YES	YES	YES
MAX REWORK SPECIFIED	NO	YES	YES
ENCAPSULANT	GEL COAT	SEES™	SEES™
PRE-CAP VISUAL	YES - INDUSTRIAL	YES - CLASS H	YES - CLASS H
TEMP CYCLE (-55°C TO +125°C)	NO	YES	YES
BURN-IN	NO	YES - 96 HOURS	YES - 160 HOURS
ELECTRICAL TESTING	YES - 25°C	YES - 25°C	YES - FULL TEMP
EXTERNAL VISUAL	YES - SAMPLE	YES - SAMPLE	YES
XRAY	NO	NO	NO
PIN FINISH	NI	NI	NI

NOTE: ADDITIONAL SCREENING IS AVAILABLE SUCH AS XRAY, CSAM, MECHANICAL SHOCK, ETC. CONTACT FACTORY FOR QUAL STATUS.

MECHANICAL SPECIFICATIONS

REF	MIN	MAX	REF	MIN	MAX
A	3.970	4.020	P	0.195	0.230
B	2.470	2.510	Q	0.310	0.340
C*	0.940	0.950	R	0.500	0.700
D	1.885	1.895	S*	0.100	
E	0.160	0.170	T	0.200	0.300
F	0.265	0.275	U	0.500	0.550
G	0.430	0.440	V		0.400
H	0.208	0.225	W	0.225	0.235
J*	0.975	0.985	X	0.185	0.195
K*	1.645	1.745	Y*	0.050	
L	3.385	3.395	Z	0.090	0.110
M*	0.240		Aa	0.000	0.008
N	0.985	1.015			

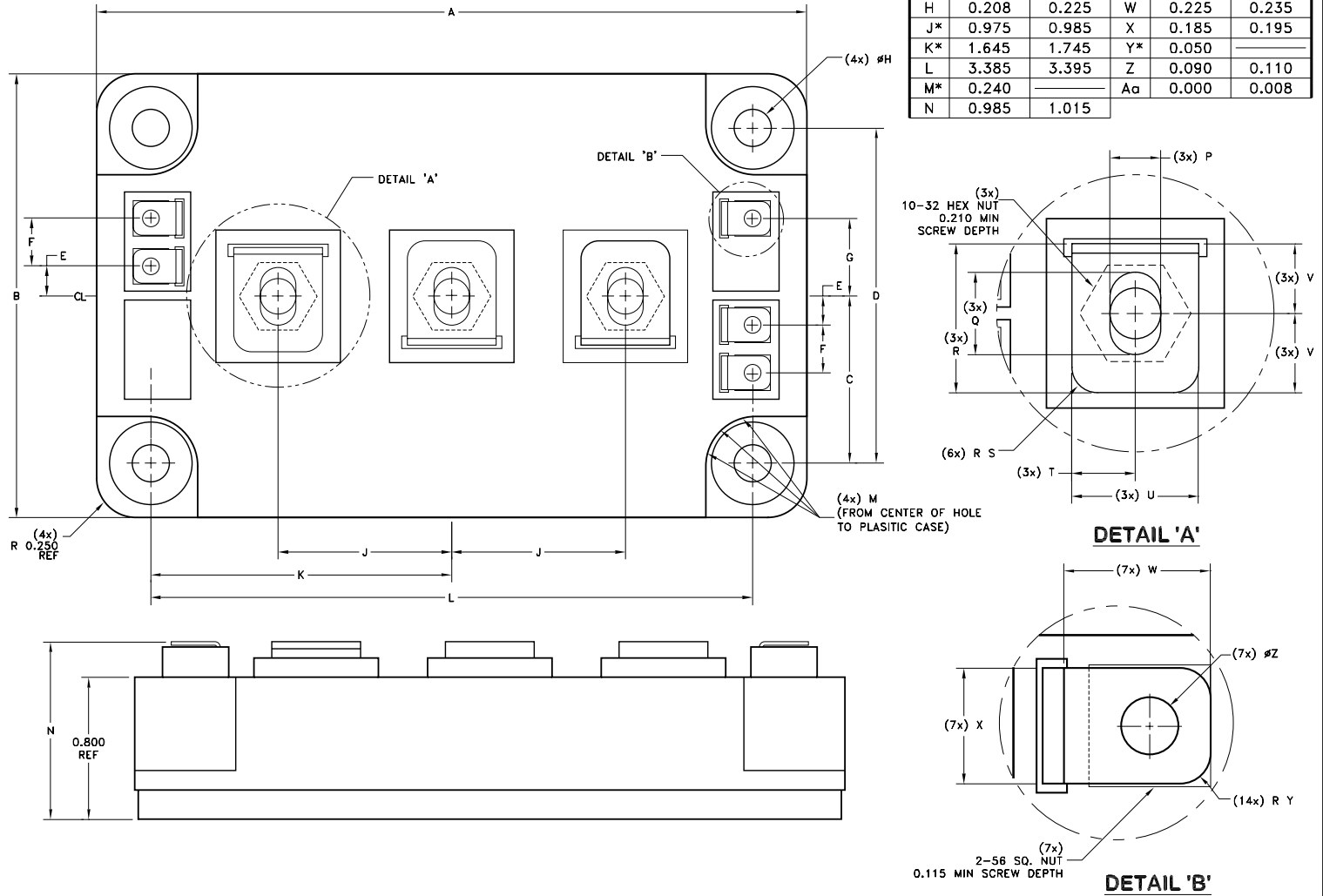

WEIGHT = 250 GRAMS MAX.

ORDERING INFORMATION

MSK4803 H

SCREENING

BLANK = INDUSTRIAL; E = EXTENDED RELIABILITY;
H = MIL-PRF-38534 CLASS H (MODIFIED)

GENERAL PART NUMBER

THE ABOVE EXAMPLE IS A MILITARY SCREENED MODULE.

M.S. Kennedy Corp.
4707 Dey Road Liverpool, New York 13088
Phone (315) 701-6751
FAX (315) 701-6752
www.mskennedy.com

The information contained herein is believed to be accurate at the time of printing. MSK reserves the right to make changes to its products or specifications without notice, however, and assumes no liability for the use of its products. Please visit our website for the most recent revision of this datasheet.