

Dot Matrix LED

■ General Description

Sharp's dot matrix LEDs can express characters and symbols on a display. (Number of dots: 5×7, 8×8, 16×16). We can supply wide color variation; high-luminosity red T series, yellow-green E series, sunset orange S series, dichromatic emission, etc.

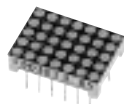

LT5038T

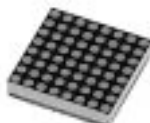

LT5017ED

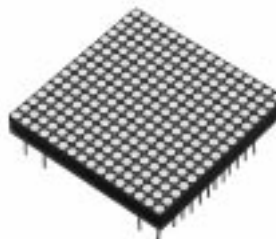

LT5040ET

■ Dot Matrix LED

Number of dots	Outline dimensions (mm)	*Common pins	Radiation color					Outline dimensions			
			T Red (High-luminosity)	D Red	S Sunset orange	E Yellow-green	E T Yellow-green+ Red (High-luminosity)	E D Yellow green + Red	Page	Figure	
			5×7	12.7×17.8	K A	LT5038T LT5037T					
8×8	20×20	K K						LT5017ED LT5027ED	186		1 2 3
		A K	LT5010T	LT5010D							
	A A		LT5105D		LT5105E						
	30.2×30.2	A A		LT5106D	LT5106S	LT5106E					
16×16	31.8×31.8	K A					LT5007ED	187		4 5 5/6	
		A A	LT5013T		LT5014D	LT5014S					
16×16	31.9×31.9	A A					LT5040ET	188		6 7 8	
		K A			LT5005S						
	A A		LT5005T				LT5050ET				
	40×40	A A						LT5026ED		9 10 11	
96×96	A										

*1 Common pins show row.(Column row)

Dot Matrix LED

■ Absolute Maximum Ratings Figures shown below are values per dot.

(Ta=25°C)

Number of dots	Outline dimensions (mm)	Radiation color	Model No.		Forward current I _F (mA)	Peak forward current I _{FM} (mA)	Derating factor (mA/°C) Pulse	Reverse voltage V _R (V)	Operating temperature T _{opr.} (°C)	Storage temperature T _{stg.} (°C)	
			Anode common*1	Cathode common*1							
5X7	12.7X17.8	Red(High-luminosity)	LT5037T	LT5038T	15	50 ^{*2}	1.45	5	-20 to +60	-20 to +80	
		Yellow-green/Red		LT5017ED	15	50 ^{*2}	0.91	5	-20 to +60	-20 to +80	
8X8	20X20	Yellow-green/Red		LT5027ED	15	50 ^{*2}	0.91	5	-20 to +60	-20 to +80	
		Red(High-luminosity)	LT5010T		15	50 ^{*2}	0.91	5	-20 to +60	-20 to +70	
	Red	LT5010D		15	50 ^{*2}	0.91	5	-20 to +60	-20 to +80		
	Red	LT5106D	LT5105D	20	50 ^{*2}	0.91	5	-20 to +70	-20 to +80		
	Sunset orange	LT5106S		20	50 ^{*2}	0.91	5	-20 to +70	-20 to +80		
	Yellow-green	LT5106E	LT5105E	20	50 ^{*2}	0.91	5	-20 to +60	-20 to +80		
	31.8X31.8	Yellow-green/Red		LT5007ED	15	50 ^{*2}	0.91	5	-20 to +60	-20 to +80	
		Red	LT5008D		15	50 ^{*2}	0.91	5	-20 to +60	-20 to +80	
	16X16	31.9X31.9	Red(High-luminosity)		LT5013T	15	80 ^{*3}	1.45	5	-20 to +60	-20 to +80
			Red	LT5014D		15	80 ^{*3}	1.45	5	-20 to +60	-20 to +80
Sunset orange			LT5014S		15	80 ^{*3}	1.45	5	-20 to +60	-20 to +80	
31.7X31.7		Yellow-green/Red(High-luminosity)	LT5040ET		15	50 ^{*2}	1.45	5	-20 to +60	-20 to +80	
		Red(High-luminosity)	LT5005T		15	80 ^{*3}	1.45	5	-20 to +60	-20 to +80	
40X40		Sunset orange		LT5005S	15	80 ^{*3}	1.45	5	-20 to +60	-20 to +80	
		Yellow-green/Red(High-luminosity)	LT5050ET		15/15	50/50 ^{*3}	1.45/1.45	5/5	-20 to +60	-20 to +80	
96X96		Yellow-green/Red	LT5026ED		15	80 ^{*3}	1.45	5	-20 to +60	-20 to +80	

*1 Common pins show row.(Column row) *2 Duty ratio=1/10, Pulse width=0.1ms

*3 Duty ratio=1/16, pulse width=0.1ms

■ Electro-optical Characteristics Figures shown below are values per dot.

(Ta=25°C)

Number of dots	Outline dimensions (mm)	Radiation color	Model No.		Forward voltage*2 V _F (V)		Luminous intensity*3 I _v (mcd) TYP.	Peak emission wavelength λ _p (nm) TYP.	Spectrum radiation bandwidth Δλ(nm) TYP.		Reverse current I _R (μA) MAX. V _R (V)		
			Anode common*1	Cathode common*1	TYP.	MAX.			I _F (mA)	I _R (μA) MAX.	V _R (V)		
5X7	12.7X17.8	Red(High-luminosity)	LT5037T	LT5038T	1.85	3.0	(4.5)	660	20	50	100	4	
		Yellow-green/Red*		LT5017ED	2.4/2.2	3.0	1.9/1.6	565/635	30/35	50	10	4	
8X8	20X20	Yellow-green/Red*		LT5027ED	2.4/2.2	3.0	2.5/2.0	565/635	30/35	50	10	4	
		Red(High-luminosity)	LT5010T		1.85	2.3	2.2	660	20	50	10	4	
	Red	LT5010D		2.2	2.7	1.11	635	35	50	10	4		
	Red	LT5106D	LT5105D	2.2	2.7	1.11	635	35	10	10	4		
	Sunset orange	LT5106S		2.2	2.7	1.11	610	35	10	10	4		
	Yellow-green	LT5106E	LT5105E	2.4	2.7	1.69	565	30	10	10	4		
	31.8X31.8	Yellow-green/Red*		LT5007ED	2.4/2.2	3.0/2.7	2.08/1.56	565/635	30/35	50	10	4	
		Red	LT5008D		2.2	3.0	2.03	635	35	50	10	4	
	16X16	31.9X31.9	Red(High-luminosity)		LT5013T	1.85	3.0	1.35	660	20	50	10	4
			Red	LT5014D		2.2	3.0	1.3	635	50	35	10	4
Sunset orange			LT5014S		2.2	3.0	1.11	610	35	50	10	4	
31.7X31.7		Yellow-green/Red(High-luminosity)*	LT5040ET		2.4/1.85	3.0	1.45/1.70	565/660	30/20	50	100	3	
		Red(High-luminosity)	LT5005T		1.85	3.0	1.78	660	20	50	10	4	
40X40		Sunset orange		LT5005S	2.2	2.7	1.11	610	35	50	10	4	
		Yellow-green/Red(High-luminosity)*	LT5050ET		2.4/1.85	3.0	(1.9)/(3.0)	565/660	30/20	10	100	3	
96X96		Yellow-green/Red*	LT5026ED		2.4/2.2	3.0	7.15/5.85	565/635	30/35	50	10	4	

* Each figure shown in the table is yellow-green/red. *1 Common pins show row.(Column row) *2 I_{FM}=50mA *3 I_F=10mA

Dot Matrix LED Outline Dimensions(Unit:mm)

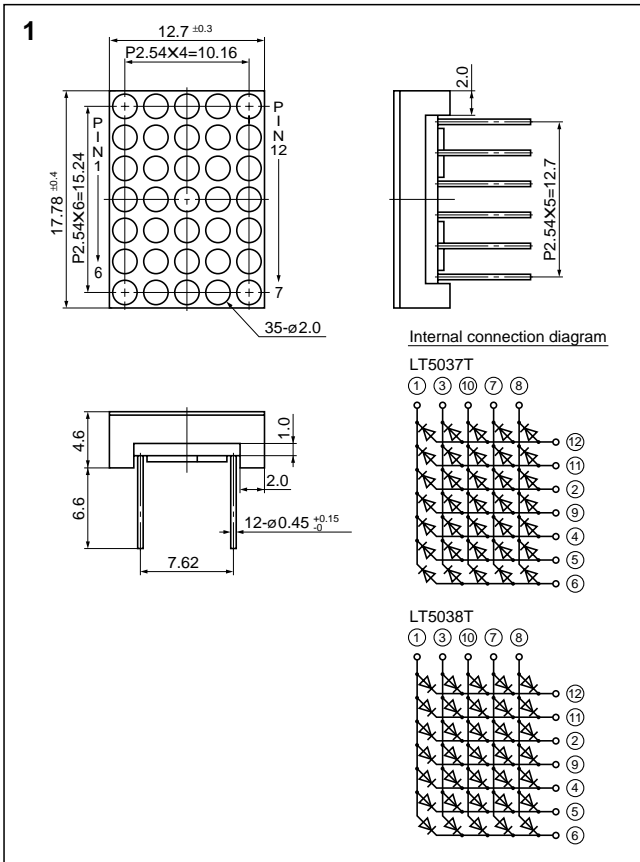

LT5037T/LT5038T

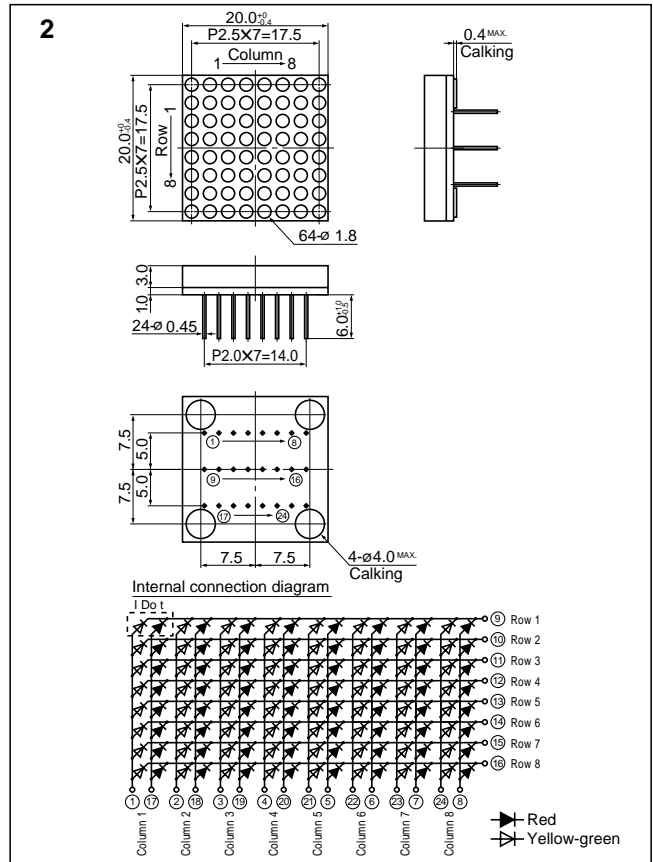

LT5017ED

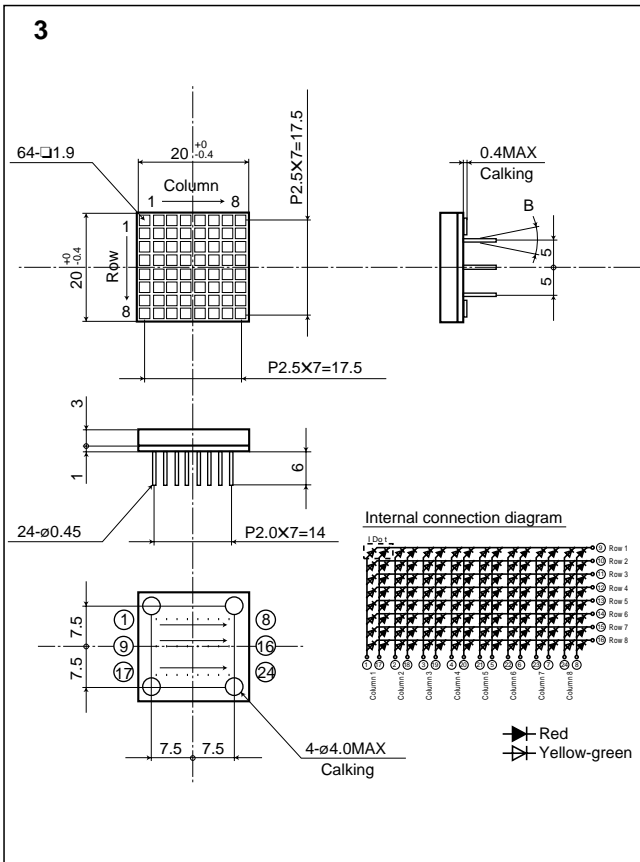

LT5027ED

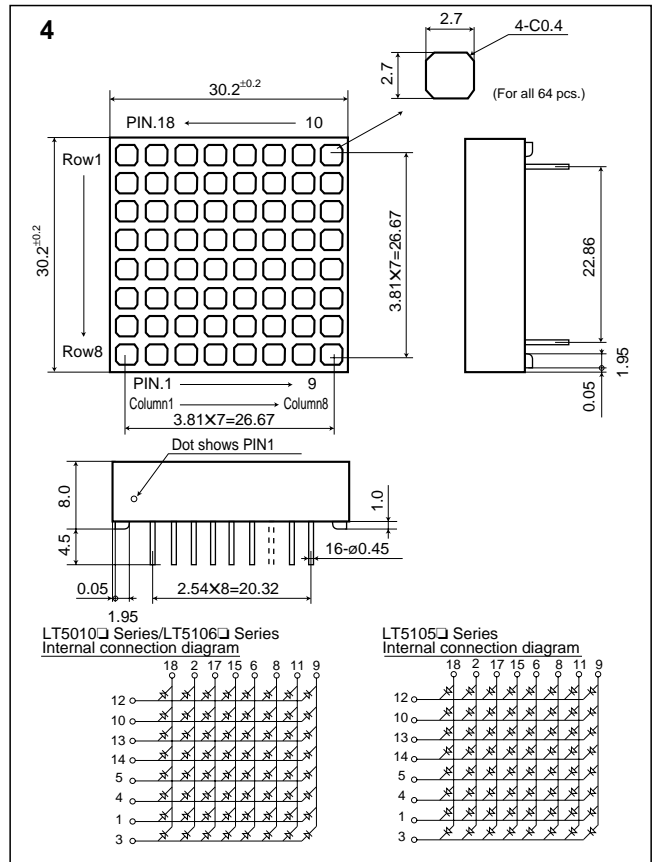

LT5010 Series LT50105 Series/LT50106 Series

Dot Matrix LED Outline Dimensions(Unit:mm)

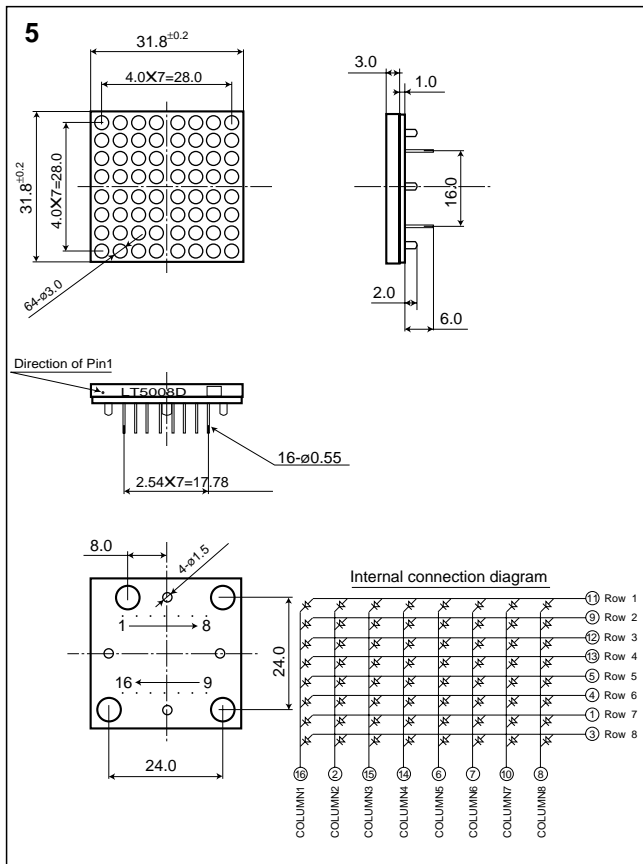

LT5008□ Series

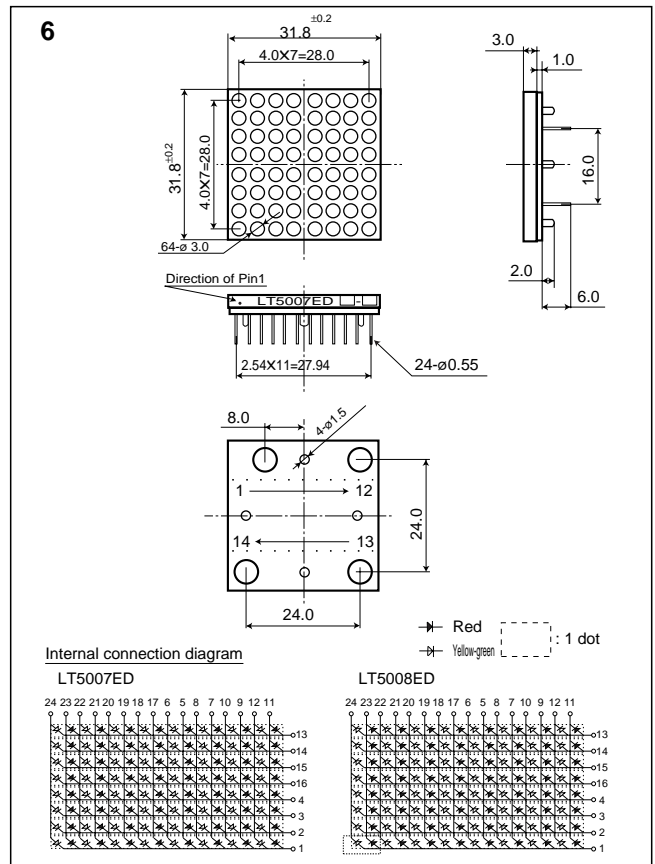

LT5007ED/LT5008ED

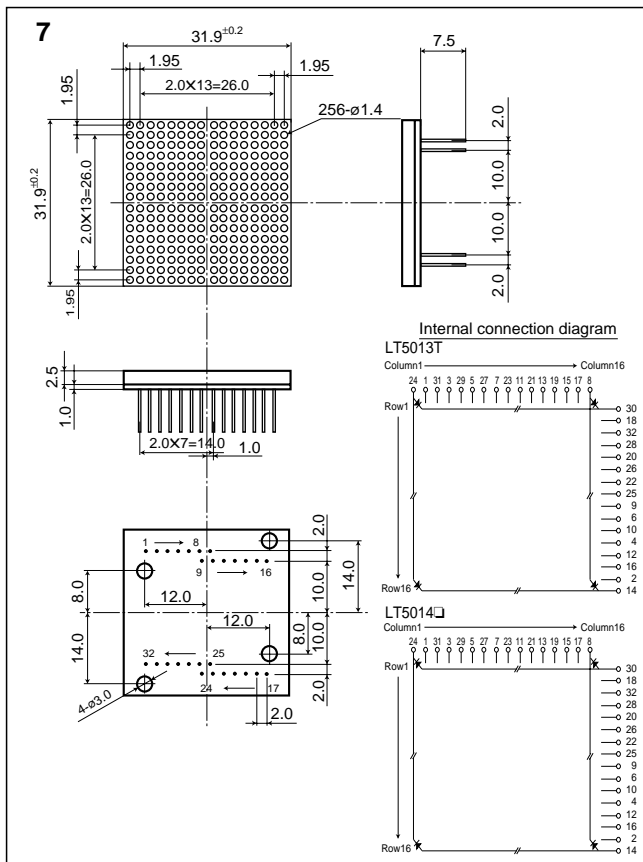

LT5013T/LT5014□ Series

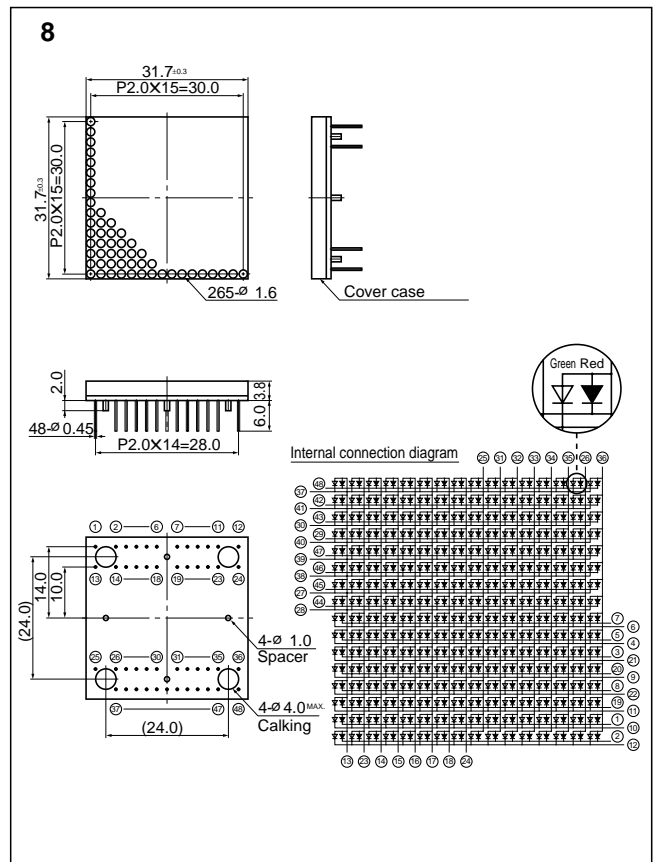

LT5040ET

NOTICE

- The circuit application examples in this publication are provided to explain representative applications of SHARP devices and are not intended to guarantee any circuit design or license any intellectual property rights. SHARP takes no responsibility for any problems related to any intellectual property right of a third party resulting from the use of SHARP's devices.
- Contact SHARP in order to obtain the latest device specification sheets before using any SHARP device. SHARP reserves the right to make changes in the specifications, characteristics, data, materials, structure, and other contents described herein at any time without notice in order to improve design or reliability. Manufacturing locations are also subject to change without notice.
- Observe the following points when using any devices in this publication. SHARP takes no responsibility for damage caused by improper use of the devices which does not meet the conditions and absolute maximum ratings to be used specified in the relevant specification sheet nor meet the following conditions:
 - (i) The devices in this publication are designed for use in general electronic equipment designs such as:
 - Personal computers
 - Office automation equipment
 - Telecommunication equipment [terminal]
 - Test and measurement equipment
 - Industrial control
 - Audio visual equipment
 - Consumer electronics
 - (ii) Measures such as fail-safe function and redundant design should be taken to ensure reliability and safety when SHARP devices are used for or in connection with equipment that requires higher reliability such as:
 - Transportation control and safety equipment (i.e., aircraft, trains, automobiles, etc.)
 - Traffic signals
 - Gas leakage sensor breakers
 - Alarm equipment
 - Various safety devices, etc.
 - (iii) SHARP devices shall not be used for or in connection with equipment that requires an extremely high level of reliability and safety such as:
 - Space applications
 - Telecommunication equipment [trunk lines]
 - Nuclear power control equipment
 - Medical and other life support equipment (e.g., scuba).
- Contact a SHARP representative in advance when intending to use SHARP devices for any "specific" applications other than those recommended by SHARP or when it is unclear which category mentioned above controls the intended use.
- If the SHARP devices listed in this publication fall within the scope of strategic products described in the Foreign Exchange and Foreign Trade Control Law of Japan, it is necessary to obtain approval to export such SHARP devices.
- This publication is the proprietary product of SHARP and is copyrighted, with all rights reserved. Under the copyright laws, no part of this publication may be reproduced or transmitted in any form or by any means, electronic or mechanical, for any purpose, in whole or in part, without the express written permission of SHARP. Express written permission is also required before any use of this publication may be made by a third party.
- Contact and consult with a SHARP representative if there are any questions about the contents of this publication.