

FEATURES

- 10-, 12-, and 14-Bit binary models
- 3-digit BCD model
- 20 MHz Reference bandwidth
- 2 ppm/°C Gain tempco
- +5V dc and +15V dc Supply versions
- Input protected

GENERAL DESCRIPTION

The DAC-HA Series are high performance multiplying digital-to-analog converters specifically designed for critical applications. The series features 10-, 12-, and 14-bit models and a 3-digit BCD model with a choice of either +5V dc or +15V dc power supply options. They are fabricated with advanced thin-film hybrid technology combining low ON-resistance CMOS switches with a precision laser trimmed R-2R ladder network. The ladder network is deposited on glass to realize low distributed capacitance resulting in a 20 MHz minimum reference bandwidth. Digital and power supply inputs are protected against overvoltage and latchup.

The DAC-HA series offer significant performance advantages over similar monolithic multiplying DAC's while retaining the industry 7500-Series pin compatibility. Tightly controlled process parameters hold the ladder resistance to 10K ohms \pm 30% rather than the -50%, +100% tolerance common to monolithic versions. Close temperature tracking between the R-2R ladder and the feedback resistor results in a typical gain tempco of 2 ppm/°C. Linearity error is $\pm 1/2$ LSB maximum for the 10- and 12-bit models and ± 1 LSB maximum for the 14-bit model.

The +5V dc supply versions draw only 1 μ A of supply current while the +15V dc supply versions draw 1.4 mA; both have optimized accuracy at the specified supply voltages. Different models are also available for three standard operating temperature ranges along with MIL-STD-883 level B versions. The units are packaged in hermetically sealed 16-, 18-, or 20-pin ceramic packages for the 10-, 12-, and 14-bit versions respectively.

Applications include digitally controlled attenuators, automatic gain control circuits, CRT character generation, one, two- or four-quadrant multiplier circuits, one- or two-quadrant divider circuits, complex function circuits and automatic bridge circuits.

CAUTION: These devices contain CMOS circuits and should be handled with standard anti-static procedures.

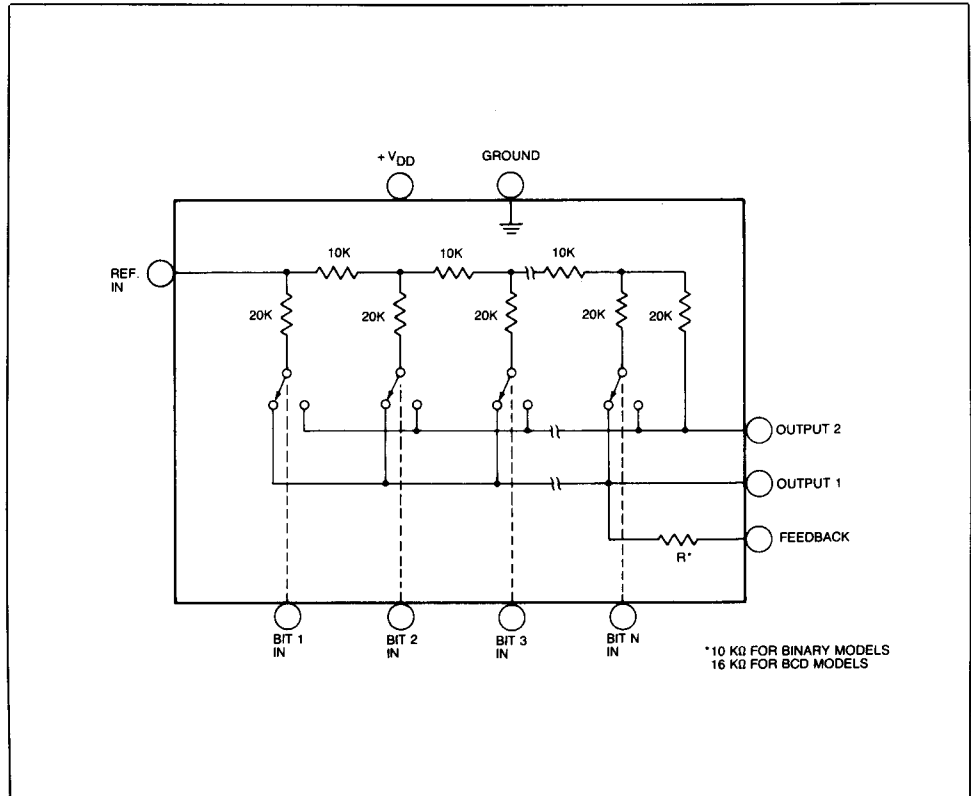

INPUT/OUTPUT CONNECTIONS

DAC-HA10B		DAC-HA12B, 12D		DAC-HA14B	
PIN	FUNCTION	PIN	FUNCTION	PIN	FUNCTION
1	OUTPUT 1	1	OUTPUT 1	1	OUTPUT 1
2	OUTPUT 2	2	OUTPUT 2	2	OUTPUT 2
3	GROUND	3	GROUND	3	GROUND
4	BIT 1 IN (MSB)	4	BIT 1 IN (MSB)	4	BIT 1 IN (MSB)
5	BIT 2 IN	5	BIT 2 IN	5	BIT 2 IN
6	BIT 3 IN	6	BIT 3 IN	6	BIT 3 IN
7	BIT 4 IN	7	BIT 4 IN	7	BIT 4 IN
8	BIT 5 IN	8	BIT 5 IN	8	BIT 5 IN
9	BIT 6 IN	9	BIT 6 IN	9	BIT 6 IN
10	BIT 7 IN	10	BIT 7 IN	10	BIT 7 IN
11	BIT 8 IN	11	BIT 8 IN	11	BIT 8 IN
12	BIT 9 IN	12	BIT 9 IN	12	BIT 9 IN
13	BIT 10 IN (LSB)	13	BIT 10 IN	13	BIT 10 IN
14	+VDD	14	BIT 11 IN	14	BIT 11 IN
15	REFERENCE IN	15	BIT 12 IN (LSB)	15	BIT 12 IN
16	FEEDBACK	16	+VDD	16	BIT 13 IN
		17	REFERENCE IN	17	BIT 14 IN (LSB)
		18	FEEDBACK	18	+VDD
				19	REFERENCE IN
				20	FEEDBACK

ABSOLUTE MAXIMUM RATINGS	DAC-HA14B	DAC-HA12B	DAC-HA12D	DAC-HA10B
V _{DD} , +5V dc Supply Option	+15V dc, -10V dc	*	*	*
V _{DD} , +15V dc Supply Option	+40V dc, -30V dc	*	*	*
Logic Input Voltage	+10V dc, -5V dc	*	*	*
Reference Input Voltage	±25V dc	*	*	*
Output 1 or Output 2 Voltage	+5V dc, -0.5V dc	*	*	*
Feedback Resistor to Gnd	±25V dc	*	*	*

FUNCTIONAL SPECIFICATIONS

Typical at 25°C, V_{REF} = +10V dc, +5V dc standard or, +15V dc optional¹ power supply.

INPUTS				
Resolution	14 Bits	12 Bits	3 digits	10 Bits
Coding, Unipolar Operation	Straight Binary	*	BCD	*
Coding, Bipolar Operation	Offset Binary	*	—	*
Logic Threshold, Bit ON ("1") ²	≥ +4.0V dc	*	*	*
Logic Threshold, Bit OFF ("0") ²	≤ +1.0V dc	*	*	*
Logic Input Current ³	±1 μA	*	*	*
Reference Input Voltage Range	±12V dc	*	*	*
Reference Input Resistance	10K ±30%	*	*	*
Reference Input Resistance vs Temp.	0 to +50 ppm/°C	*	*	*
OUTPUTS				
Output Current Range, Either Output	± V _{REF} /R _{IN}	*	*	*
Output Capacitance, Output 1 ⁴	260 pF	260 pF	260 pF	55 pF
Output Capacitance, Output 2 ⁴	160 pF	160 pF	160 pF	18 pF
Output Capacitance, Output 1 ⁵	160 pF	160 pF	160 pF	18 pF
Output Capacitance, Output 2 ⁵	260 pF	260 pF	260 pF	55 pF
PERFORMANCE				
Integral Linearity Error ⁶ , maximum	±1 LSB	± ½ LSB	± ½ LSB	± ½ LSB
Differential Linearity Error ⁶	± ½ LSB typ. ± 1 LSB max.	± ¼ LSB typ. ± ½ LSB max.	± ¼ LSB typ. ± ½ LSB max.	± ¼ LSB typ. ± ½ LSB max.
Differential Linearity Error Over Temp ⁶	±2 LSB max.	± 1 LSB max.	± 1 LSB max.	± 1 LSB max.
Gain Linearity Error, maximum	±1 LSB	± ½ LSB	± ½ LSB	± ½ LSB
Gain Error, Before Trimming ⁷	+0, -0.2%	*	*	*
Output Leakage Current, maximum ⁸	500 pA	500 pA	500 pA	250 pA
Gain Temp. Coefficient, ppm/°C ⁹	2 typ., 5 max. At 25°C	2 typ., 5 max. Over Temp Range	2 typ., 5 max. Over Temp Range	20 typ., 50 max. Over Temp Range
Monotonicity	7 μseconds	5 μseconds	5 μseconds	1.3 μseconds
Output Current Settling time, maximum ¹⁰	7 μseconds	5 μseconds	5 μseconds	1.3 μseconds
Reference Input Bandwidth, -3 dB	20 MHz	*	*	*
Feedthrough at 20 kHz	0.025%	0.025%	0.025%	0.01%
Power Supply Rejection	5 ppm of FSR/%	5 ppm of FSR/%	5 ppm of FSR/%	0.01% of FSR/%
POWER REQUIREMENTS				
Standard Version Supply Voltage	+5V dc	*	*	*
Standard Version Supply Range	+3V dc to +7.5V dc	*	*	*
Standard Version Supply Current, maximum	1 μA	*	*	*
Optional Version Supply Voltage ¹	+15V dc	*	*	*
Optional Version Supply Range	+7.5V dc to +20V dc	*	*	*
Optional Version Supply Current, maximum	1.4 mA	*	*	*
PHYSICAL/ENVIRONMENTAL				
Operating Temp. Range, C Suffix	0°C to 70°C	*	*	*
R Suffix	-25°C to +85°C	*	*	*
M Suffix	-55°C to +125°C	*	*	*
Storage Temp. Range	-65°C to +150 °C	*	*	*
Package Type, Ceramic	20 Pin DIP	18 Pin DIP	18 Pin DIP	16 Pin DIP

FOOTNOTES:

- | | |
|--|--|
| <ol style="list-style-type: none"> 1. The optional +15V dc version is designated by the Suffix -1. 2. Interfaces with TTL logic. See Technical Notes 3. Over Operating Temperature Range 4. All Digital Inputs high 5. All Digital Inputs low | <ol style="list-style-type: none"> 6. V_{OUT 1} = V_{OUT 2} = ±200 mV 7. Adjustable to Zero 8. At +125°C Leakages are 500 nA and 250 nA maximum respectively. 9. Using feedback resistor. 10. To ½ LSB for full scale digital input change. |
|--|--|

*Specification same as first column.

TECHNICAL NOTES

1. **CAUTION.** The DAC-HA series contains MOS devices and should be handled carefully to prevent static charge pickup that might damage the units. The converters should be kept in conductive foam until ready for installation. During installation the user should be grounded by means of a conductive wrist strap. Do not insert or remove these devices from their sockets unless power is turned off.
2. Unused digital inputs should be connected to ground or to +5V, never left open.
3. In general, pull-up resistors are not required for TTL logic interfacing. The DAC-HA series will interface directly with all standard TTL circuits and operate within specifications.
4. The logic input voltages are stated as $\leq +1.0V$ for a logic "0" and $\geq +4.0V$ for a logic "1" at the recommended power supply voltages of +5V or +15V. For other supply voltages in the specified range, the logic "1" level becomes $V_{DD} - 1$ for the 5V version and $\frac{V_{DD}}{3} - 1$ for the +15V version.
5. For interfacing with HNIL or CMOS logic where logic high is greater than +5V, CD4050 interface circuits should be used and connected as shown in the applications diagram.
6. The DAC-HA series devices are protected against both power supply and logic input overvoltages by means of series thin-film resistors. The result is that these devices are free from latch-up problems which have been associated with some CMOS multiplying DAC circuits in the past.
7. While the DAC-HA series gives optimum accuracy at recommended supply voltage and at room temperature, the maximum linearity error is ± 1 LSB over both specified supply range and temperature range for the 10 and 12 bit models and is ± 2 LSB for the 14 bit model.
8. The supply current is given as the quiescent value. The current increases to 200 μA maximum for the +5V version and 1.6 mA maximum for the +15V version with all bits switched at a 10 kHz rate at 50% duty cycle. Supply current increases at the rate of 1 μA per kHz of switching frequency.
9. The noise output of the DAC-HA devices can be computed from the Johnson noise of the resistance between either output terminal and ground. This resistance varies with input code from 6.67K (based on nominal ladder resistance of 10K) to 30K for Output 2 and from 6.67K to infinity for Output 1. When using an output amplifier at either output the feedback resistor is then in parallel with the ladder resistance, and the noise gain of the amplifier must also be used in the computation.
10. Feedthrough, which is specified at 20 kHz, is due to capacitive coupling from the reference input to the output, and increases directly with frequency. The frequency of the reference input is only limited by the amount of feedthrough error.
11. It is recommended that output amplifiers with less than 25 nA input bias current be used with the DAC-HA series. This permits precise adjustment of the output voltage to zero with all digital inputs OFF and at the same time assures that the input offset voltage is minimized. For most applications the 356 type op amp is an excellent choice. For faster response, however, DATEL's AM-462 is recommended.

CONNECTIONS

DAC-HA CONNECTION WITH 356 OUTPUT AMPLIFIER

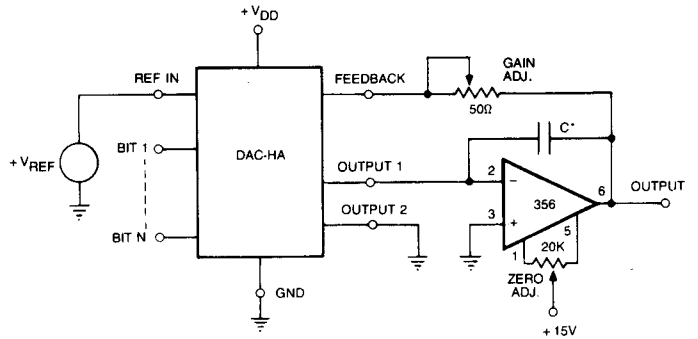

*USE 3 TO 30pF TRIM CAPACITOR AND ADJUST FOR OPTIMUM STEP RESPONSE.

2

DAC-HA CONNECTION FOR FAST VOLTAGE OUTPUT USING DATEL AM-462 MONOLITHIC OPERATIONAL AMPLIFIER

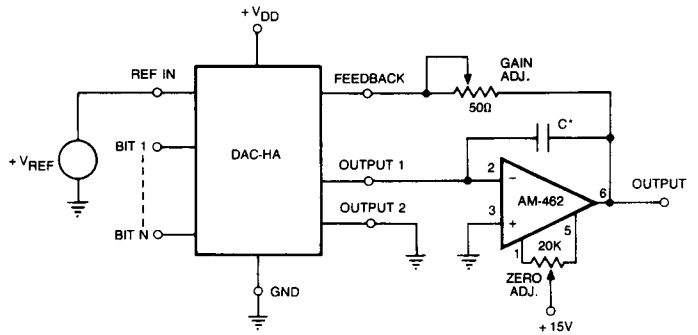

*USE 3 TO 30pF TRIM CAPACITOR AND ADJUST FOR OPTIMUM STEP RESPONSE.

CMOS OR HNIL LOGIC INTERFACE

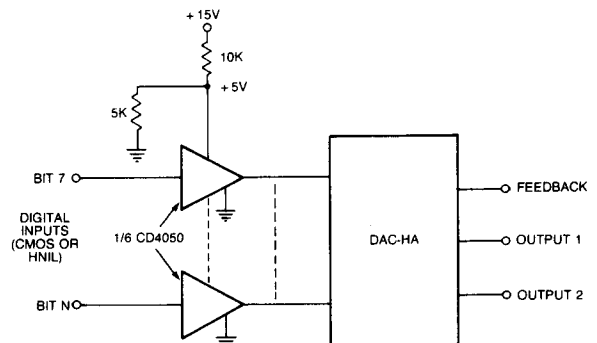

THEORY OF OPERATION

The circuit of the DAC-HA series uses a precision, thin-film R-2R ladder network with $R = 10K \text{ ohms} \pm 30\%$, as shown in Figure 1. An external reference source is applied at the input of the network, and, depending on the digital input code, the resulting current is split between the Output 1 and Output 2 terminals. The switches at the bottom of the 20K network resistors are low on-resistance, single-pole, double-throw CMOS devices of the type shown in Figure 2. The equivalent input impedance seen by the reference source is shown in Figure 3.

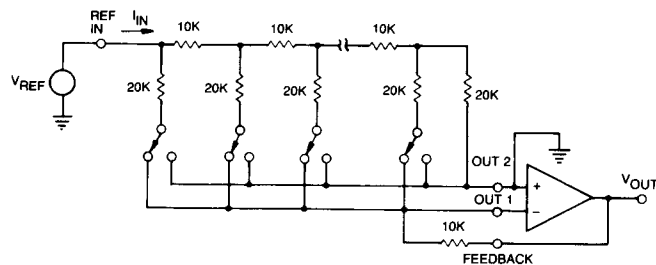

Figure 1. Precision DAC-HA Circuit

From the reference end of the network, the input current divides in two at each successive junction as it flows down the ladder. It should be noted that the 20K terminating resistor at the right end of the network goes to Output 2 in the DAC-HA series rather than to ground as in monolithic devices of the 7500 type. The output currents at Output 1 and Output 2 represent the digital complements of one another except for a 1 LSB analog difference. The result is that when Output 1 and Output 2 are added together they always sum to the reference input current.

Furthermore, with a digital input code of 1000 . . . 0000, the two output currents are precisely equal. Therefore, in 4 quadrant multiplying applications where the two outputs are subtracted, the result is zero. With 7500 series monolithic units these currents do not cancel each other and an additional 1 LSB offset current must be externally provided to give exact cancellation.

The DAC-HA series are designed to be used with an external operational amplifier which converts the current output into a voltage. Since the feedback resistor tracks the ladder network with temperature, the resulting gain tempco is $\pm 2 \text{ ppm}/^\circ\text{C}$ typical except for the 10 bit model. If the output current is used without the internal feedback resistor, the output current tempco is then 0 to $-50 \text{ ppm}/^\circ\text{C}$.

CODING TABLE

CODE	SCALE	OUTPUT 1	OUTPUT 2
1111 . . . 11	FS-1 LSB	$I_{IN}(1 - 2^{-n})$	$I_{IN}(2^{-n})$
1100 . . . 00	$+ \frac{3}{4}$ FS	$I_{IN}(2^{-1} + 2^{-2})$	$I_{IN}(2^{-2})$
1000 . . . 01	$+ \frac{1}{2}$ FS + 1 LSB	$I_{IN}(2^{-1} + 2^{-n})$	$I_{IN}(2^{-1} - 2^{-n})$
1000 . . . 00	$+ \frac{1}{2}$ FS	$I_{IN}(2^{-1})$	$I_{IN}(2^{-1})$
0100 . . . 00	$+ \frac{1}{4}$ FS	$I_{IN}(2^{-2})$	$I_{IN}(2^{-1} + 2^{-2})$
0000 . . . 01	+ 1 LSB	$I_{IN}(2^{-n})$	$I_{IN}(1 - 2^{-n})$
0000 . . . 00	0	$I_{IN}(0)$	$I_{IN}(1)$

NOTE: $I_{IN} = \frac{V_{REF}}{R_{IN}}$

where R_{IN} is ladder network impedance, or $10k \pm 30\%$

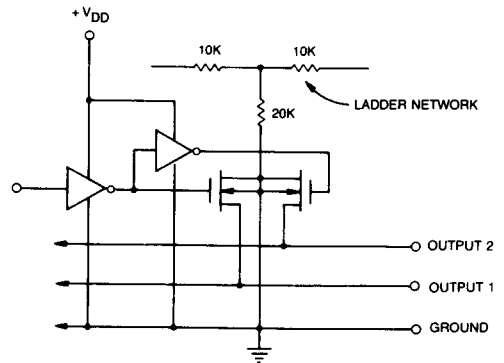

Figure 2. Single-Pole, Double-Throw CMOS Switch

With an external amplifier at Output 1 the output voltage ranges from zero to $-V_{REF}(1 - 2^{-n})$, depending on the input code. If an external amplifier is used at Output 2 with the same value of feedback resistor, the output voltage ranges from zero to $-V_{REF}$ depending on input code.

The DAC-HA series have optimized linearity for the two power supply options +5V and +15V. It should be noted that while 7500 series devices operate over a +5V to +15V supply range, nonlinearity increases as the supply voltage is decreased from +15V.

To realize the specified linearity, it is necessary to carefully zero the input offset voltage of the amplifier or amplifiers used at the outputs. The input offset voltage should be zeroed to less than $\pm 0.1 \text{ mV}$ in order to have negligible effect on accuracy. Actually the two offset voltages can be as large as $\pm 200 \text{ mV}$ if they are within $\pm 0.1 \text{ mV}$ of each other.

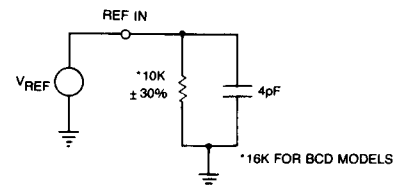

Figure 3. Equivalent Input Impedance of DAC-HA Reference Input

OUTPUT EQUATIONS

OUTPUT 1 = $I_{IN}(a_1 2^{-1} + a_2 2^{-2} + a_3 2^{-3} + \dots + a_n 2^{-n})$

OUTPUT 2 = $I_{IN}(\bar{a}_1 2^{-1} + \bar{a}_2 2^{-2} + \bar{a}_3 2^{-3} + \dots + \bar{a}_n 2^{-n} + 2^{-n})$

“a’s” are digital coefficients, 0 or 1.
n = converter resolution in bits

APPLICATIONS

**2-QUADRANT MULTIPLICATION
(DIGITAL ATTENUATOR)**

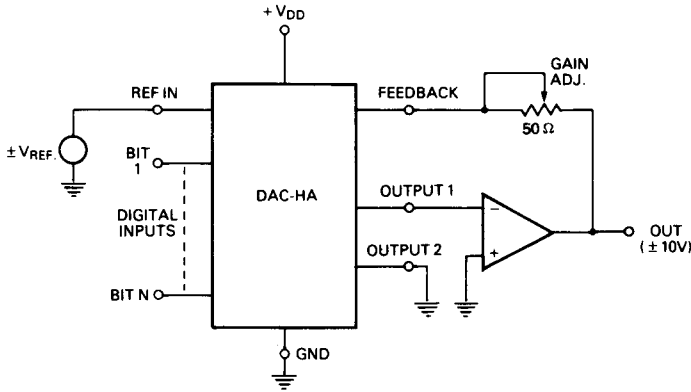

4-QUADRANT MULTIPLICATION

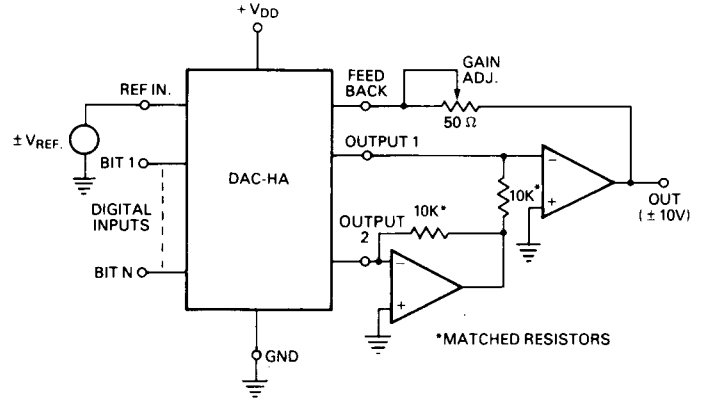

2

DIVISION CIRCUIT USING DAC-HA

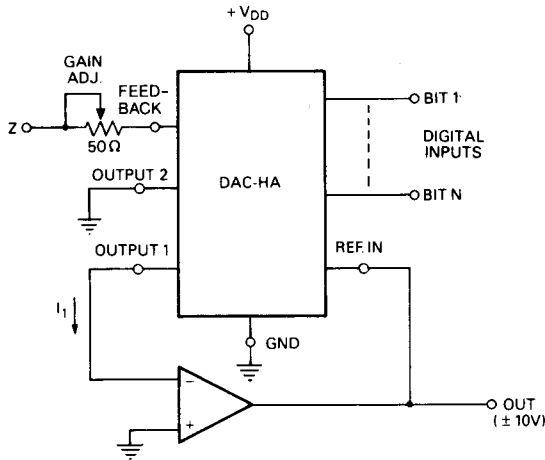

(D) = Digital Input = $(a_1 2^{-1} + a_2 2^{-2} + a_3 2^{-3} + \dots + a_n 2^{-n})$

$I_1 = \frac{OUT(D)}{R}$ where R is internal ladder resistance = 10K

$I_1 = \frac{-Z}{R}$ R is feedback resistor which is matched to internal ladder resistance.

$\frac{OUT(D)}{R} = \frac{-Z}{R}$ **OUT = $\frac{-Z}{(D)}$**

The circuit is stable for $\pm Z$.

A × B × C CIRCUIT

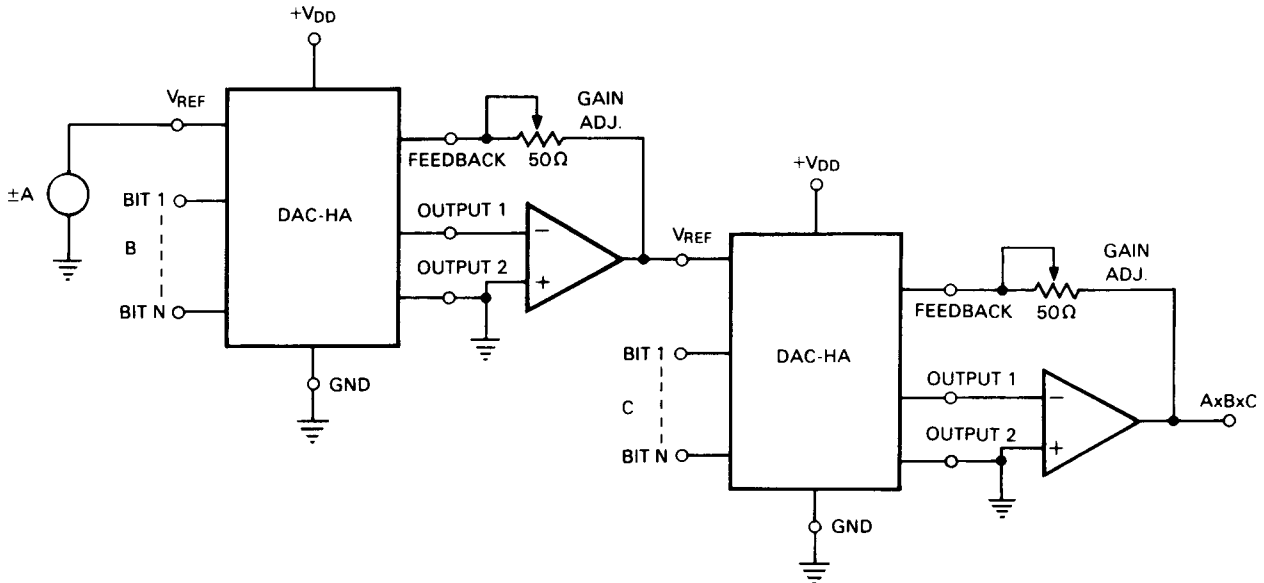

DIMENSIONS & ORDERING

MECHANICAL DIMENSIONS—INCHES (MM)

16-PIN DIP CERAMIC PACKAGE

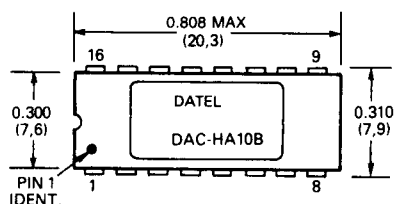

18-PIN DIP CERAMIC PACKAGE

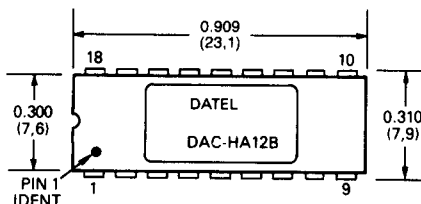

20-PIN DIP CERAMIC PACKAGE

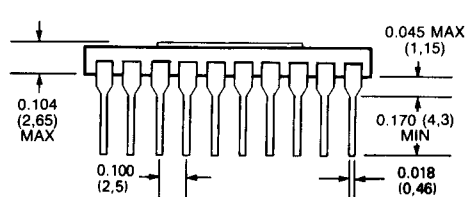
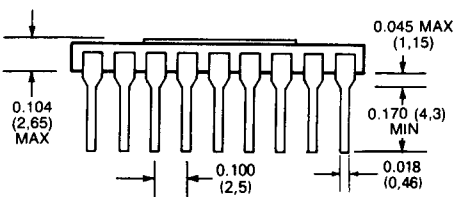
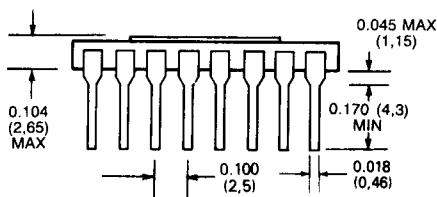
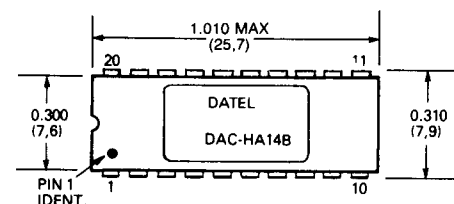

ORDERING INFORMATION

MODEL NO.	OPERATING TEMP. RANGE	POWER SUPPLY	MODEL NO.	OPERATING TEMP. RANGE	POWER SUPPLY
DAC-HA10BC	0 to 70°C	+5V dc	DAC-HA10BC-1	0 to 70°C	+15V dc
DAC-HA10BR	-25 to +85°C	+5V dc	DAC-HA10BR-1	-25 to +85°C	+15V dc
DAC-HA10BM	-55 to +125°C	+5V dc	DAC-HA10BM-1	-55 to +125°C	+15V dc
DAC-HA12BC	0 to 70°C	+5V dc	DAC-HA12BC-1	0 to 70°C	+15V dc
DAC-HA12BR	-25 to +85°C	+5V dc	DAC-HA12BR-1	-25 to +85°C	+15V dc
DAC-HA12BM	-55 to +125°C	+5V dc	DAC-HA12BM-1	-55 to +125°C	+15V dc
DAC-HA12DC	0 to 70°C	+5V dc	DAC-HA12DC-1	0 to 70°C	+15V dc
DAC-HA12DR	-25 to +85°C	+5V dc	DAC-HA12DR-1	-25 to +85°C	+15V dc
DAC-HA12DM	-55 to +125°C	+5V dc	DAC-HA12DM-1	-55 to +125°C	+15V dc
DAC-HA14BC	0 to 70°C	+5V dc	DAC-HA14BC-1	0 to 70°C	+15V dc
DAC-HA14BR	-25 to +85°C	+5V dc	DAC-HA14BR-1	-25 to +85°C	+15V dc
DAC-HA14BM	-55 to +125°C	+5V dc	DAC-HA14BM-1	-55 to +125°C	+15V dc

ACCESSORIES

Part Number	Description
TP50	Trimming Potentiometer

For military devices compliant to MIL-STD-883, consult the factory.

THESE CONVERTERS ARE COVERED BY GSA CONTRACT