

400 WATT TVS COMPONENT



APPLICATIONS

- Power Supply
- AC/DC Applications
- Telecom

FEATURES

- UL Registered
- IEC 61000-4-2 (ESD): Level 4 - Air 15kV, Contact 8kV
- IEC 61000-4-4 (EFT): 40A 5/50ns
- IEC 61000-4-5 (Surge): 8/20 μ s Waveform
- Glass Passivated Chip
- 400 Watts Peak Pulse Power per Line (tp = 10/1000 μ s)
- Low Leakage Current
- Bidirectional and Unidirectional Configurations
- Excellent Clamping Capability
- Very Fast Response Time
- Available in Multiple Voltages
- RoHS Compliant
- REACH Compliant

MECHANICAL CHARACTERISTICS

- Molded JEDEC DO-214AC Package
- Approximate Weight: 0.06 grams
- Lead-Free Pure-Tin Plating (Annealed)
- Solder Reflow Temperature:
Pure-Tin - Sn, 100: 260-270°C
- 12mm Tape and Reel Per EIA Standard 481
- Terminal: Solderable per MIL-STD-750, Method 2026
- Flammability Rating UL 94V-0

PIN CONFIGURATIONS

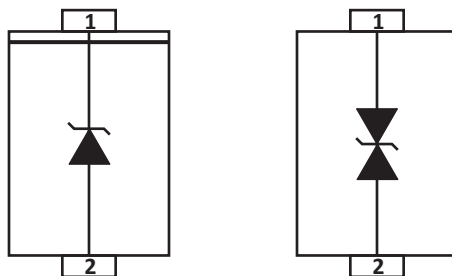

TYPICAL DEVICE CHARACTERISTICS

MAXIMUM RATINGS @ 25°C Unless Otherwise Specified

PARAMETER	SYMBOL	VALUE	UNITS
Operating Temperature	T_J	-55 to 150	°C
Storage Temperature	T_{STG}	-55 to 150	°C
Peak Pulse Power (tp =10/1000µs) - See Figure 1 and Note 1	P_{PP}	400	Watts
Power Dissipation on Infinite Heatsink at $T_L = 75^\circ\text{C}$	P_D	1.0	Watts
Peak Forward Surge Current, 8.3ms single half sinewave - Unidirectional Only (Note 2)	I_{FSM}	40	Amps
Maximum Instantaneous Forward Voltage at 25A - Unidirectional Only (Note 3)	V_F	3.5/5.0	V

NOTE

1. Non-repetitive current pulse per Figure 2 and derated above $T_A = 25^\circ\text{C}$ per Figure 3.
2. Measured on 8.3ms single half sinewave or equivalent square wave, duty cycle = 4 pulses per minute maximum.
3. $V_F < 3.5\text{V}$.

ELECTRICAL CHARACTERISTICS PER LINE @ 25°C Unless Otherwise Specified

PART NUMBER (Notes 1-2)	DEVICE MARKING		REVERSE STAND-OFF VOLTAGE V_{RWM} VOLTS	BREAKDOWN VOLTAGE $V_{(BR)} @ I_T$ VOLTS		TEST CURRENT @ I_T mA	MAXIMUM CLAMPING VOLTAGE (Fig. 2) @ I_P V_C VOLTS	MAXIMUM REVERSE SURGE CURRENT @ I_{PP} AMPS	MAXIMUM REVERSE LEAKAGE CURRENT @ V_{RWM} I_R µA
	UNI	BI		MIN	MAX				
SMAJ5.0A	AE	WE	5.0	6.40	7.00	10	9.2	43.5	800
SMAJ6.0A	AG	WG	6.0	6.67	7.37	10	10.3	38.8	800
SMAJ6.5A	AK	WK	6.5	7.22	7.98	10	11.2	35.7	500
SMAJ7.0A	AM	WM	7.0	7.78	8.60	10	12.0	33.3	200
SMAJ7.5A	AP	WP	7.5	8.33	9.21	1	12.9	31.0	100
SMAJ8.0A	AR	WR	8.0	8.89	9.83	1	13.6	29.4	50
SMAJ8.5A	AT	WT	8.5	9.44	10.40	1	14.4	27.8	10
SMAJ9.0A	AV	VV	9.0	10.00	11.10	1	15.4	26.0	5
SMAJ10A	AX	WX	10.0	11.10	12.30	1	17.0	23.5	5
SMAJ11A	AZ	WZ	11.0	12.20	13.50	1	18.2	22.0	1
SMAJ12A	BE	XE	12.0	13.30	14.70	1	19.9	20.1	1
SMAJ13A	BG	XG	13.0	14.40	15.90	1	21.5	18.6	1
SMAJ14A	BK	XK	14.0	15.60	17.20	1	23.2	17.2	1
SMAJ15A	BM	XM	15.0	16.70	18.50	1	24.4	16.4	1
SMAJ16A	BP	XP	16.0	17.80	19.70	1	26.0	15.4	1
SMAJ17A	BR	XR	17.0	18.90	20.90	1	27.6	14.5	1
SMAJ18A	BT	XT	18.0	20.00	22.10	1	29.2	13.7	1
SMAJ19A	BB	XB	19.0	21.10	23.30	1	30.8	13.0	1
SMAJ20A	BV	XV	20.0	22.20	24.50	1	32.4	12.4	1
SMAJ22A	BX	XX	22.0	24.40	26.90	1	35.5	11.3	1
SMAJ24A	BZ	XZ	24.0	26.70	29.50	1	38.9	10.3	1

TYPICAL DEVICE CHARACTERISTICS

ELECTRICAL CHARACTERISTICS PER LINE @ 25°C Unless Otherwise Specified

PART NUMBER (Notes 1-2)	DEVICE MARKING		REVERSE STAND-OFF VOLTAGE V_{RWM} VOLTS	BREAKDOWN VOLTAGE $V_{(BR)} @ I_T$ VOLTS		TEST CURRENT @ I_T mA	MAXIMUM CLAMPING VOLTAGE (Fig. 2) @ I_P V_C VOLTS	MAXIMUM REVERSE SURGE CURRENT @ I_{PP} AMPS	MAXIMUM REVERSE LEAKAGE CURRENT @ V_{RWM} I_R μ A
	UNI	BI		MIN	MAX				
	SMAJ26A	CE	YE	26.0	28.90	31.90	1	42.1	9.5
SMAJ28A	CG	YG	28.0	31.10	34.40	1	45.4	8.8	1
SMAJ30A	CK	YK	30.0	33.30	36.80	1	48.4	8.3	1
SMAJ33A	CM	YM	33.0	36.70	40.60	1	53.3	7.5	1
SMAJ36A	CP	YP	36.0	40.00	44.20	1	58.1	6.9	1
SMAJ40A	CR	YR	40.0	44.40	49.10	1	64.5	6.2	1
SMAJ43A	CT	YT	43.0	47.80	52.80	1	69.4	5.8	1
SMAJ45A	CV	YV	45.0	50.00	55.30	1	72.7	5.5	1
SMAJ48A	CX	YX	48.0	53.30	58.90	1	77.4	5.2	1
SMAJ51A	CZ	YZ	51.0	56.70	62.70	1	82.4	4.9	1
SMAJ54A	RE	ZE	54.0	60.00	66.30	1	87.1	4.6	1
SMAJ58A	RG	ZG	58.0	64.40	71.20	1	93.6	4.3	1
SMAJ60A	RK	ZK	60.0	66.70	73.70	1	96.8	4.1	1
SMAJ64A	RM	ZM	64.0	71.10	78.60	1	103.0	3.9	1
SMAJ70A	RP	ZP	70.0	77.80	86.00	1	113.0	3.5	1
SMAJ75A	RR	ZR	75.0	83.30	92.10	1	121.0	3.3	1
SMAJ78A	RT	ZT	78.0	86.70	95.80	1	126.0	3.2	1
SMAJ80A	RB	ZB	80.0	88.80	97.60	1	129.6	3.1	1
SMAJ85A	RV	ZV	85.0	94.40	104.00	1	137.0	2.9	1
SMAJ90A	RX	ZX	90.0	100.00	111.00	1	146.0	2.7	1
SMAJ100A	RZ	ZZ	100.0	111.00	123.00	1	162.0	2.5	1
SMAJ110A	SE	VE	110.0	122.00	135.00	1	177.0	2.3	1
SMAJ120A	SG	VG	120.0	133.00	147.00	1	193.0	2.1	1
SMAJ130A	SK	VK	130.0	144.00	159.00	1	209.0	1.9	1
SMAJ140A	SB	VB	140.0	155.00	171.00	1	226.8	1.7	1
SMAJ150A	SM	VM	150.0	167.00	185.00	1	243.0	1.7	1
SMAJ160A	SP	VP	160.0	178.00	197.00	1	259.0	1.5	1
SMAJ170A	SR	VR	170.0	189.00	209.00	1	275.0	1.5	1
SMAJ180A	ST	VT	180.0	200.00	220.00	1	291.6	1.4	1
SMAJ190A	SV	VV	190.0	211.00	232.00	1	307.8	1.3	1
SMAJ200A	SW	VW	200.0	224.00	247.00	1	324.0	1.2	1
SMAJ220A	SX	VX	220.0	246.00	272.00	1	356.0	1.1	1
SMAJ250A	SZ	VZ	250.0	279.00	309.00	1	405.0	1.0	1
SMAJ300A	DE	HE	300.0	335.00	371.00	1	486.0	0.8	1

TYPICAL DEVICE CHARACTERISTICS

ELECTRICAL CHARACTERISTICS PER LINE @ 25°C Unless Otherwise Specified

PART NUMBER (Notes 1-2)	DEVICE MARKING		REVERSE STAND-OFF VOLTAGE V_{RWM} VOLTS	BREAKDOWN VOLTAGE $V_{(BR)} @ I_T$ VOLTS		TEST CURRENT @ I_T mA	MAXIMUM CLAMPING VOLTAGE (Fig. 2) @ I_p V_c VOLTS	MAXIMUM REVERSE SURGE CURRENT @ I_{PP} AMPS	MAXIMUM REVERSE LEAKAGE CURRENT @ V_{RWM} I_R μA
	UNI	BI		MIN	MAX				
SMAJ350A	DG	HG	350.0	391.00	432.00	1	567.0	0.7	1
SMAJ400A	DK	HK	400.0	447.00	494.00	1	648.0	0.6	1
SMAJ440A	DM	HM	440.0	492.00	543.00	1	713.0	0.6	1

NOTE

- Suffix 'A' denotes 5% tolerance.
- Add suffix 'CA' after part number to specify a bidirectional device.

TYPICAL DEVICE CHARACTERISTICS

**FIGURE 1
PEAK PULSE POWER VS PULSE TIME**

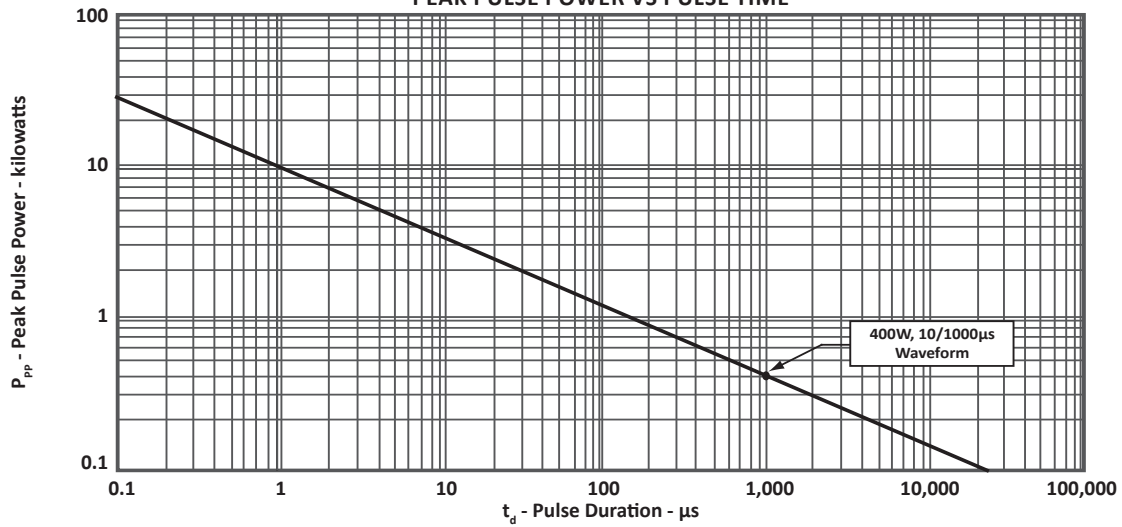

**FIGURE 2
PULSE WAVEFORM**

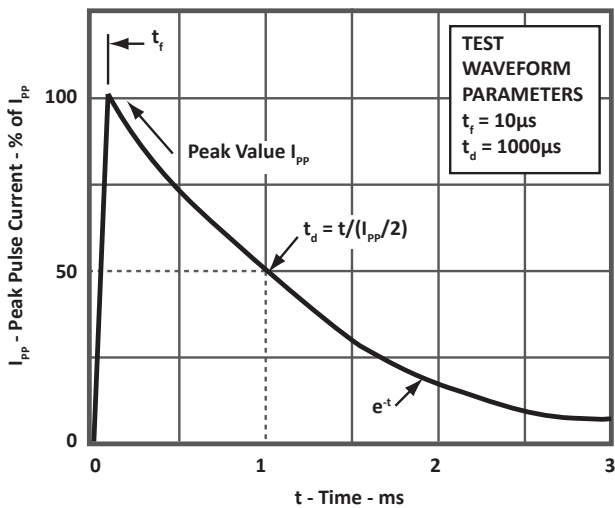

**FIGURE 3
POWER DERATING CURVE**

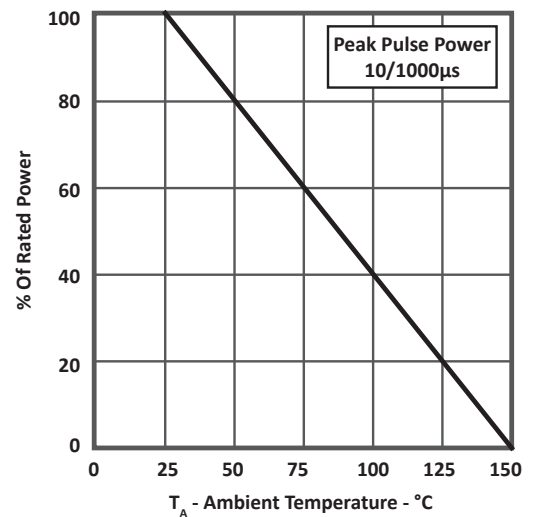

TYPICAL DEVICE CHARACTERISTICS

FIGURE 4
TYPICAL JUNCTION CAPACITANCE

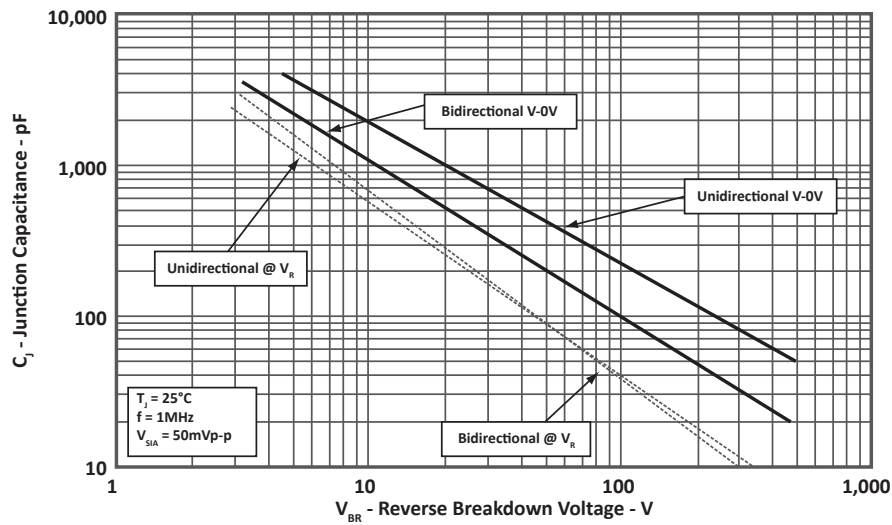

FIGURE 5
MAXIMUM NON-REPETITIVE FORWARD SURGE CURRENT

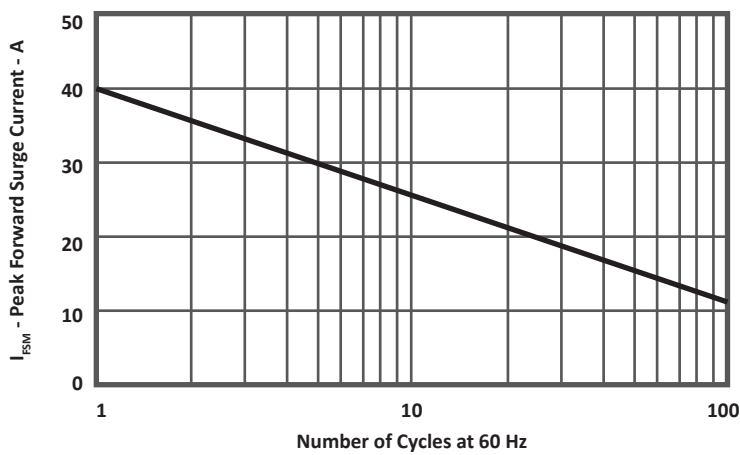
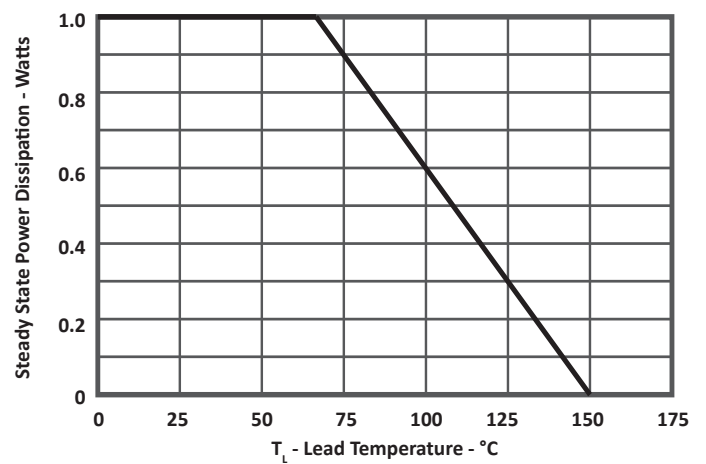

FIGURE 6
STEADY STATE POWER DERATING CURVE



DO-214AC PACKAGE INFORMATION

OUTLINE DIMENSIONS

DIM	MILLIMETERS		INCHES	
	MIN	MAX	MIN	MAX
A	1.23	1.63	0.049	0.064
B	4.10	4.55	0.162	0.179
C	2.51	2.76	0.099	0.109
D	1.96	2.26	0.077	0.089
E	0.75	1.51	0.03	0.06
F	0.00	0.20	0.000	0.008
G	4.87	5.22	0.192	0.206
H	0.15	0.30	0.006	0.012

NOTES

1. Dimensions are exclusive of mold flash and metal burrs.

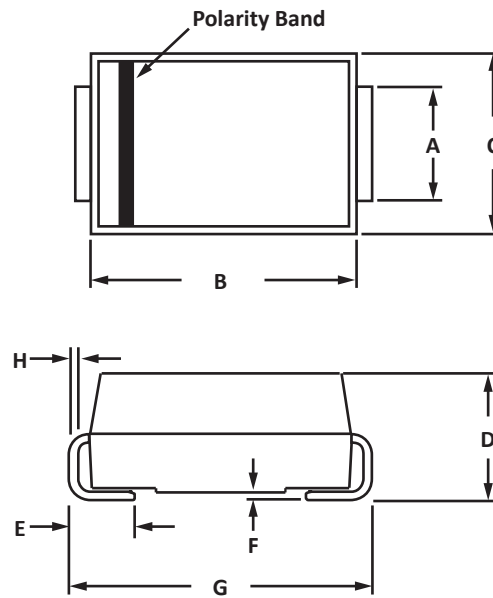

PAD LAYOUT DIMENSIONS

DIM	MILLIMETERS		INCHES	
	MIN	MAX	MIN	MAX
A	1.57	-	0.062	-
B	1.55	-	0.061	-
C	-	2.28	-	0.090
D	1.55	-	0.061	-

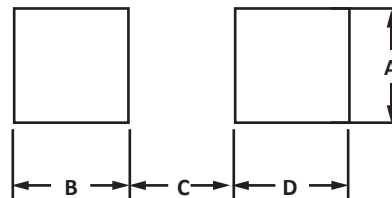

TAPE AND REEL

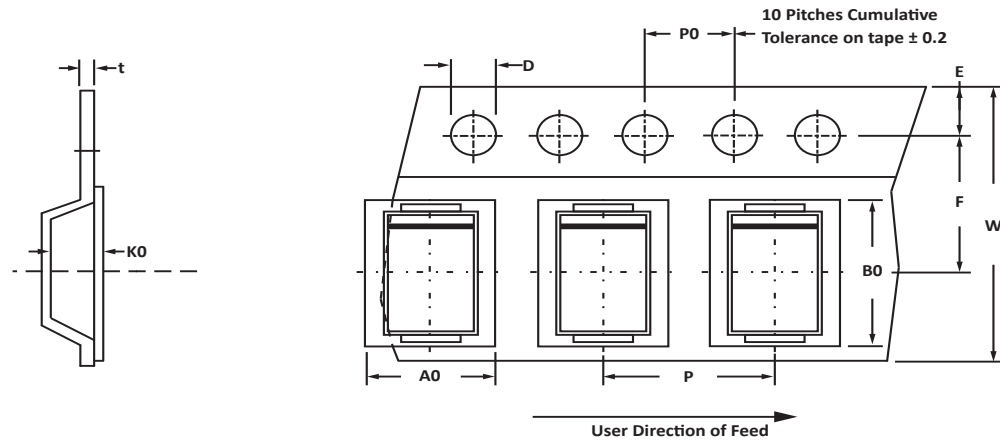

SPECIFICATIONS

REEL DIA.	TAPE WIDTH	A0	B0	K0	D	E	F	W	P0	P	tmax
330mm (13")	12mm	2.79 ± 0.10	5.33 ± 0.10	2.36 ± 0.10	1.55 ± 0.10	1.75 ± 0.10	5.5 ± 0.05	12.00 ± 0.30	4.00 ± 0.10	4.00 ± 0.10	0.4

NOTES

- Dimensions are in millimeters.
- Surface mount product is taped and reeled in accordance with EIA-481.
- Marking on Part - marking code (see page 2), date code, logo and cathode defined by polarity band.

ORDERING INFORMATION

BASE PART NUMBER (Voltage = xx)	LEADFREE SUFFIX	TAPE SUFFIX	QTY/REEL	REEL SIZE	TUBE QTY
SMAJxxA	N/A	-T13	7,500	13"	N/A
SMAJxxCA	N/A	-T13	7,500	13"	N/A

This device is only available in a Lead-Free configuration.

COMPANY INFORMATION

COMPANY PROFILE

In business more than 25 years, ProTek Devices™ is a privately held semiconductor company. The company offers a product line of overvoltage protection and overcurrent protection components. These include transient voltage suppressor array (TVS arrays) avalanche breakdown diode, steering diode TVS array and electronics SMD chip fuses. These components deliver circuit protection in electronic systems from numerous overvoltage and overcurrent events. They include lightning; electrostatic discharge (ESD); nuclear electromagnetic pulses (NEMP); inductive switching; and electromagnetic interference (EMI) / radio frequency interference (RFI). ProTek Devices also offers LED wafer die for ESD protection and related high frequency products. ProTek Devices is ISO 9001 certified company.

CONTACT US

Corporate Headquarters

2929 South Fair Lane
Tempe, Arizona 85282
USA

By Telephone

General: 602-431-8101
Sales: & Marketing: 602-414-5109
Customer Service: 602-414-5114
Product Technical Support: 602-414-5107

By Fax

General: 602-431-2288

By E-mail:

Asia Sales: asiasales@protekdevices.com
Europe Sales: europesales@protekdevices.com
U.S. Sales: ussales@protekdevices.com
Distributor Sales: distysales@protekdevices.com
Customer Service: service@protekdevices.com
Technical Support: support@protekdevices.com

ProTek Devices (Asia Pacific) Pte. Ltd.

8 Ubi Road 2, #06-19
Zervex
Singapore - 408538
Tel: +65-67488312
Fax: +65-67488313

Web

www.protekdevices.com

COPYRIGHT © ProTek Devices 2013 - This literature is subject to all applicable copyright laws and is not for resale in any manner.

SPECIFICATIONS: ProTek reserves the right to change the electrical and or mechanical characteristics described herein without notice.

DESIGN CHANGES: ProTek reserves the right to discontinue product lines without notice and that the final judgement concerning selection and specifications is the buyer's and that in furnishing engineering and technical assistance. ProTek assumes no responsibility with respect to the selection or specifications of such products. ProTek makes no warranty, representation or guarantee regarding the suitability of its products for any particular purpose, nor does ProTek assume any liability arising out of the application or use of any product or circuit and specifically disclaims any and all liability without limitation special, consequential or incidental damages.

LIFE SUPPORT POLICY: ProTek Devices products are not authorized for use in life support systems without written consent from the factory.