

Fiber Optic GaAlAs High Speed LED in SMA Receptacle Types OPF396A, OPF396B, OPF396C, OPF396D

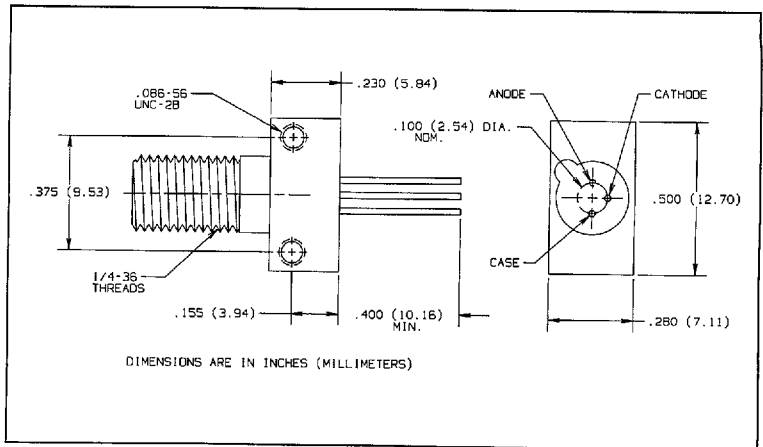
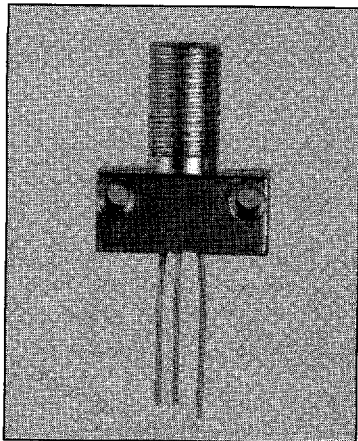

Features

- Component pre-mounted and ready to use
- Pre-tested with fiber to assure performance
- Popular SMA style receptacle
- High Speed
- Electrically isolated from case

Description

The OPF396 series LED consists of a low cost plastic cap LED, pre-mounted and aligned in an SMA receptacle. This configuration is designed for PC board or panel mounting. Includes lock washer and jam nut, two 2-56 screws, and a dust cap.

The LED's are designed to interface with multimode optical fibers from 50/125 to 200/300 microns.

Absolute Maximum Ratings (T_A = 25° C unless otherwise noted)

Reverse Voltage	1.0 V
Continuous Forward Current	100 mA ⁽⁴⁾
Storage Temperature Range	-55° C to +100° C
Operating Temperature Range	-40° C to +85° C
Lead Soldering Temperature [1/16 inch (1.6 mm) from case for 5 sec. with soldering iron].....	240° C ⁽¹⁾

Notes:

- (1) RMA flux is recommended. Duration can be extended to 10 sec. max when flow soldering.
- (2) Graded index fiber, 50 μm core, N.A. = 0.20.
- (3) To convert radiant power output to dBm, use the following expression dBm = 10 log (μW/1000).
- (4) Derate linearly @ 1.0 mA/° C above 25° C.
- (5) Prebias @ 5 mA current.

LED Burn-in

All LED's are subject to 100% burn-in testing. Test conditions are 96 hours at 100 mA continuous current in 25° C ambient.

TYPICAL COUPLED POWER into OPTICAL FIBER

Typical Coupled Power I _F = 100 mA @ 25° C						
Fiber	Refractive Index	N.A.	OPF396D	OPF396C	OPF396B	OPF396A
50/125 μm	Graded	0.20	7.5 μW	12.5 μW	18 μW	25 μW
62.5/125 μm	Graded	0.28	27 μW	35 μW	45 μW	75 μW
100/140 μm	Graded	0.29	58 μW	85 μW	115 μW	170 μW
200/300 μm*	Step	0.41	290 μW	450 μW	545 μW	650 μW

*PCS - Plastic Clad Silica

6798580 0002792 373

Types OPF396A, OPF396B, OPF396C, OPF396D

Electrical Characteristics ($T_A = 25^\circ\text{C}$ unless otherwise noted)

SYMBOL	PARAMETER	MIN	TYP	MAX	UNITS	TEST CONDITIONS
P_O	Radiant Power Output	OPF396D	5.0	7.5		$I_F = 100\text{ mA}^{(2)}$
		OPF396C	10.0	12.5	μW	
		OPF396B	15.0	18.0		
		OPF396A	20.0	25.0		
V_F	Forward Voltage		1.8	2.0	V	$I_F = 100\text{ mA}$
λ_p	Peak Output Wavelength	830	850	870	nm	$I_F = 50\text{ mA}$
B	Spectral Bandwidth Between Half Power Points		35		nm	$I_F = 50\text{ mA}$
t_r	Output Rise Time		3.5	4.5	ns	$I_F = 100\text{ mA}, 10\%-90\%^{(5)}$
t_f	Output Fall Time		3.5	4.5	ns	$I_F = 100\text{ mA}, 90\%-10\%^{(5)}$

Typical Performance Curves

Relative Coupled Power vs. Forward Current

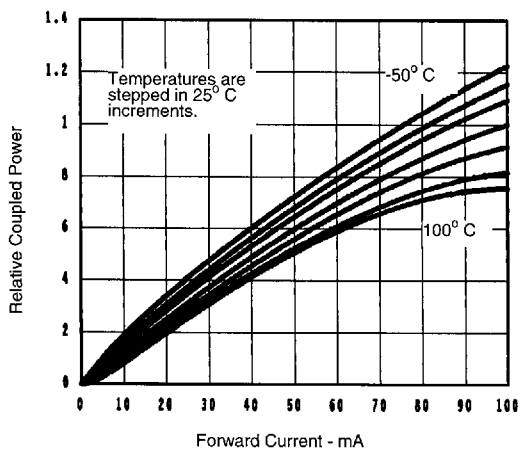

Forward Voltage vs. Forward Current

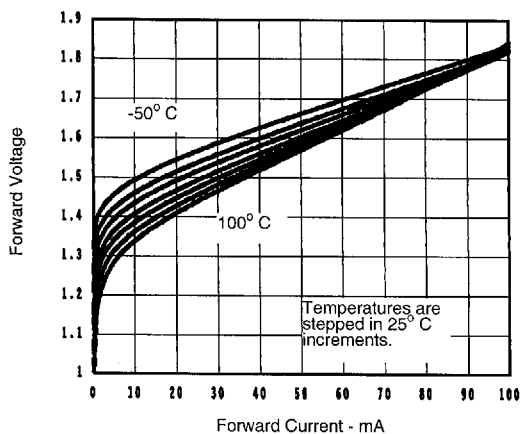

FIBER OPTIC COMPONENTS

■ 6798580 0002793 20T ■

Optek reserves the right to make changes at any time in order to improve design and to supply the best product possible.

Optek Technology, Inc. 1215 W. Crosby Road Carrollton, Texas 75006 (972)323-2200 Fax (972)323-2396