

TOSHIBA Bipolar Linear Integrated Circuit SiGe Monolithic

TA4401CT

1.9 ~ 2.5 GHz Band Power Amplifier

PHS, Digital Cordless Telecommunication Application

Wireless LAN IEEE802.11b/g Application

Bluetooth Class 1 Application

Features

- Single voltage operation : VCC = 3.0 V (typ.) for PHS
: VCC = 3.3 V (typ.) for IEEE802.11g
- Large output power : Pout = 22.5 dBmW (min.) for PHS
: Pout = 18 dBmW (min.) for IEEE802.11g
- High power gain : Gp = 35 dB (typ.) for PHS
: Gp = 27.5 dB (typ.) for IEEE802.11g
- Nano-amp shutdown mode: ICC_OFF = 20 nA (typ.) when VCON = 0 V
- Small package : CST16 (CSON16-P-0303-0.50) package
(2.9 mm × 2.9 mm × 0.48 mm)

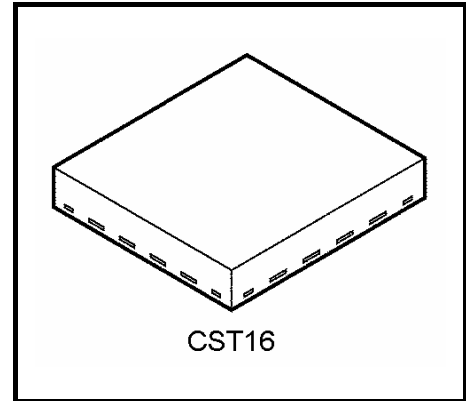

Weight: 0.012 g (typ.)

Absolute Maximum Ratings (Ta = 25°C)

Characteristic	Symbol	Rating	Unit
Supply voltage	VCC (Note 1)	3.6	V
	VCON (Note 2)	3.6	V
Input power	Pin	-3	dBmW
Power dissipation	Pd (Note 3)	1	W
Operating temperature range	Topr	-40 to +85	°C
Storage temperature range	Tstg	-55 to +150	°C

Note: Using continuously under heavy loads (e.g. the application of high temperature/current/voltage and the significant change in temperature, etc.) may cause this product to decrease in the reliability significantly even if the operating conditions (i.e. operating temperature/current/voltage, etc.) are within the absolute maximum ratings and the operating ranges.
Please design the appropriate reliability upon reviewing the Toshiba Semiconductor Reliability Handbook ("Handling Precautions"/"Derating Concept and Methods") and individual reliability data (i.e. reliability test report and estimated failure rate, etc).

Note 1: VCC = VCC1 = VCC2 = VCC3

Note 2: VCON = VCON12 = VCON3

Note 3: When mounted on 30 mm × 35 mm × 0.4 mm FR4 substrate at Ta = 25°C (double-sided substrate: the reverse side is the ground connection.)

Caution

This device is sensitive to electrostatic discharge. When handling this product, ensure that the environment is protected against electrostatic discharge by using an earth strap, a conductive mat and an ionizer.

Electrical Characteristics (22.5 dBmW for PHS)

VCC = 3 V, VCON = 2.7 V, f = 1.92 GHz, Ta = 25 °C, Zs = Zl = 50 Ω, unless otherwise noted.

Characteristic	Symbol	Test Condition	Min	Typ	Max	Unit
Operating frequency	f	—	1.880	—	1.920	GHz
Operating supply voltage	VCC	—	2.7	3.0	3.3	V
Shutdown mode leakage current	ICC_OFF	VCON = 0 V, No RF input (Pin = 0 mW)	—	20	—	nA
Supply current	ICC	384-kbps π/4-QPSK modulated signal, Pout = 22.5 dBmW, Pin = adjusted (Pin1)	—	200	225	mA
Control current	ICON		—	4	6	mA
Power gain	Gp		32	35	—	dB
Adjacent channel leakage power ratio	ACPR1	Δf = 600 kHz	—	-65	-55	dB
	ACPR2	Δf = 900 kHz	—	-70	-60	dB
Harmonics	2fo		—	-45	-30	dB
	3fo		—	-60	-30	dB
Output deviation	ΔPout	384-kbps π/4-QPSK modulated signal, f = 1880, 1920 MHz, Pin = Pin1	—	0.5	1	dB
Input VSWR	VSWRin	CW signal, Pin = -30 dBmW	—	1.5	2.5	—
Stability	—	VCC = 3.0 ~ 3.6 V, VCON = 2.7 V, Pout = 22.5 dBmW @ Zl = 50 Ω, Pin = adjusted, Zs = 50 Ω, VSWR Load = 6:1 all phases, Ta = -40 ~ +85°C	No spurious			—
Load mismatch	—	VCC = 3.6 V, VCON = 2.7 V, Pin = -6 dBmW, Zs = 50 Ω, VSWR Load = 6:1 all phases	No degradation			—

Note 4: ICON = ICON12 + ICON3

Note 5: Load condition for stability and load mismatch tests is formed with appropriate short stub connected to POUT (Pin No.10) and adjusted to all phases.

Note 6: All tests for the above electrical characteristics are measured using “Test Board 1”, shown below.

Note 7: 1/2 duty operation.

Typical Electrical Characteristics for Reference 1 (21 dBmW for PHS)

VCC = 3 V, VCON = 2.7 V, f = 1.92 GHz, Ta = 25 °C, Zs = Zl = 50 Ω, unless otherwise noted.

Characteristic	Symbol	Test Condition	Typ	Unit
Supply current	ICC	384-kbps π/4-QPSK modulated signal, Pout = 21 dBmW, Pin = adjusted	185	mA
Power gain	Gp		36	dB
Adjacent channel leakage power ratio	ACPR1	Δf = 600 kHz	-70	dB
	ACPR2	Δf = 900 kHz	-75	dB
Harmonics	2fo		-45	dB
	3fo		-60	dB

Note 8: All tests for the above typical electrical characteristics are measured using “Test Board 1”, shown below.

Typical Electrical Characteristics for Reference 2 (18 dBmW for IEEE802.11g)

VCC = 3.3 V, VCON12 = 2.5 V, VCON3 = 1.7 V, f = 2.45 GHz, Ta = 25 °C, Zs = Zl = 50 Ω, unless otherwise noted.

Characteristic	Symbol	Test Condition		Typ	Unit
Operating frequency	f	—		2.45	GHz
Operating supply voltage	VCC	—		3.3	V
Shutdown mode leakage current	ICC_OFF	VCON = 0 V, No RF input (Pin = 0 mW)		20	nA
Supply current	ICC	54-Mbps 64QAM OFDM framed signal, Pout = 18 dBmW (when unframed), Pin = adjusted		125	mA
Control current	ICON			3	mA
Power gain	Gp			27.5	dB
Error vector magnitude	EVM			3	%
Adjacent channel leakage power ratio	ACPR1	Δf = 20 MHz	54-Mbps 64QAM OFDM unframed signal, Pout = 18 dBmW, Pin = adjusted	-37	dB
	ACPR2	Δf = 40 MHz		-55	dB
Harmonics	2fo	CW signal, Pout = 18 dBmW, Pin = adjusted		-48	dB
	3fo			-55	dB

Note9: All tests for the above typical electrical characteristics are measured using "Test Board 2", shown below.

Block Diagram and Marking (Top View)

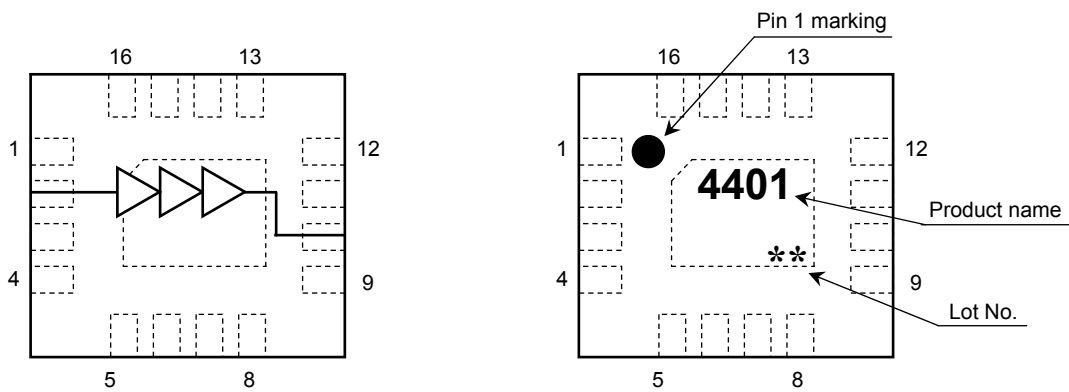

Pin Description

Number of pin	Name of pin	Description
1	NC	Not connected to the pellet. Please connect to ground.
2	PIN	RF input. DC block capacitor is built in.
3	NC	Not connected to the pellet. Please connect to ground.
4	NC	Not connected to the pellet. Please connect to ground.
5	VCON12	Control pin of 1 st stage and 2 nd stage amplifiers.
6	NC	Not connected to the pellet. Please connect to ground.
7	VCON3	Control pin of 3 rd stage amplifier.
8	NC	Not connected to the pellet. Please connect to ground.
9	NC	Not connected to the pellet. Please connect to ground.
10	VCC3/POUT	Supply pin of 3 rd stage amplifier/RF output pin.
11	NC	Not connected to the pellet. Please connect to ground.
12	NC	Not connected to the pellet. Please connect to ground.
13	NC	Not connected to the pellet. Please connect to ground.
14	VCC2	Supply pin of 2 nd stage amplifier.
15	NC	Not connected to the pellet. Please connect to ground.
16	VCC1	Supply pin of 1 st stage amplifier.
-	GND_Bed	Ground. This pin also works as heat dissipation pad.

Circuit Diagram for PHS Application (Test Board 1)

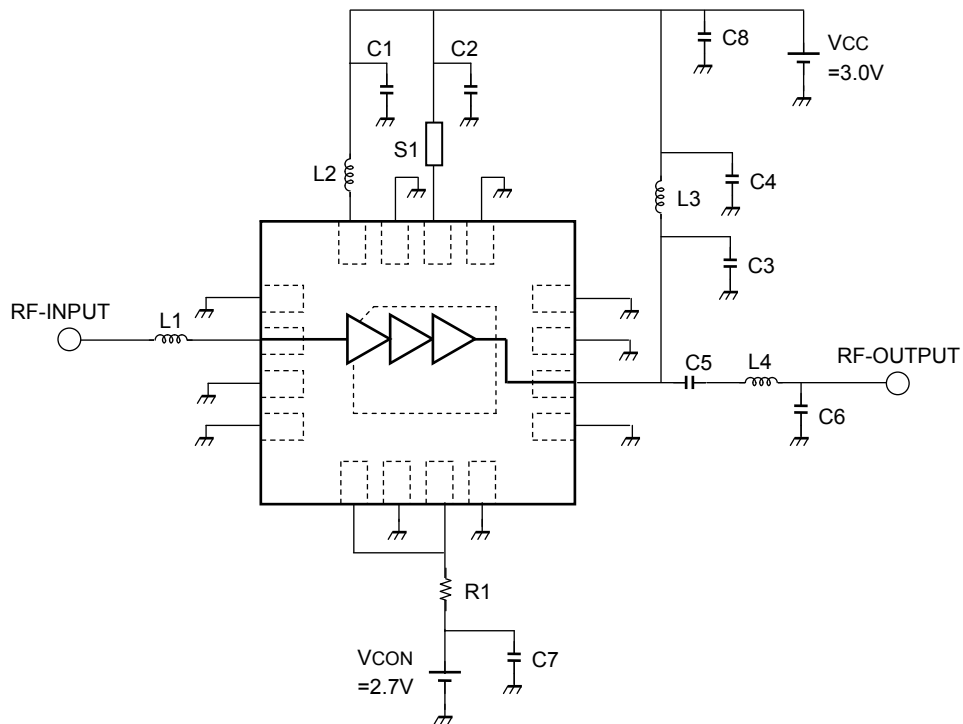

List of External Components

Part Number	Value	Chip Series	Manufacturer	Description
C1	0.1 uF	GRM15 series	MURATA	Decoupling capacitor
C2	0.1 uF	GRM15 series	MURATA	Decoupling capacitor
C3	1.5 pF	GRM15 series	MURATA	Harmonics reduction capacitor
C4	0.1 uF	GRM15 series	MURATA	Decoupling capacitor
C5	10 pF	GRM15 series	MURATA	DC blocking capacitor
C6	2 pF	GRM15 series	MURATA	PA output matching
C7	0.1 uF	GRM15 series	MURATA	Decoupling capacitor
C8	10 uF	GRM21 series	MURATA	Decoupling capacitor
L1	3 nH	LQG15HN series	MURATA	PA input matching
L2	1 nH	LQG15HN series	MURATA	PA matching
L3	27 nH	LQG15HN series	MURATA	PA output matching
L4	2 nH	LQG15HN series	MURATA	PA output matching
R1	51 Ω	MCR01 series	ROHM	VCON buffering resistor
S1	-	-	-	Micro-strip line (length = 1.2 mm, width = 0.4 mm)

Circuit Diagram for 2.45-GHz Wireless LAN Application (Test Board 2)

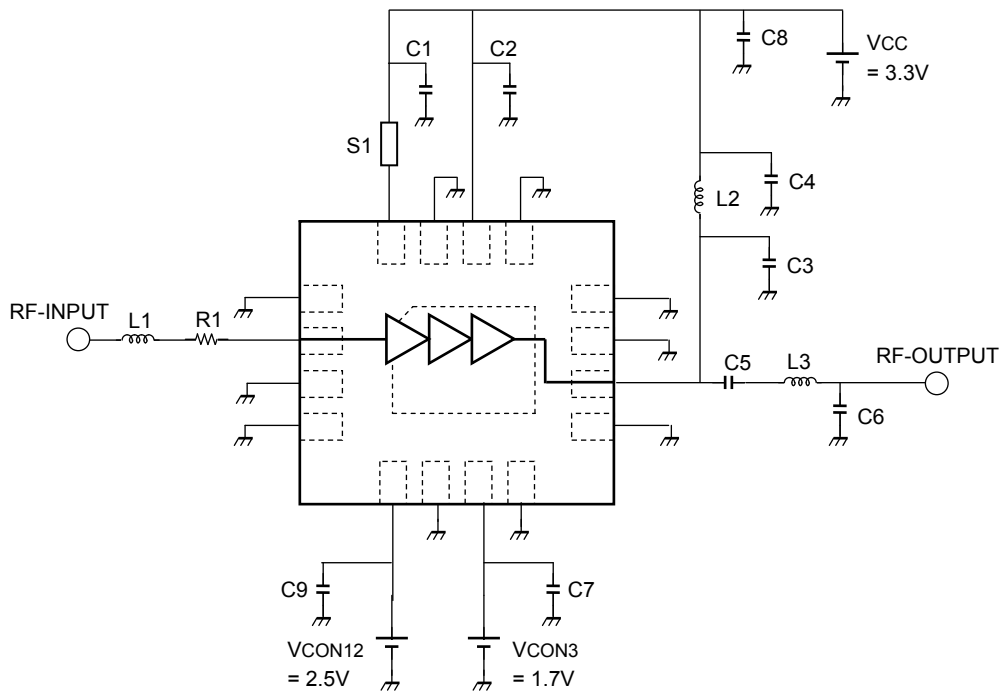

List of External Components

Part Number	Value	Chip Series	Manufacturer	Description
C1	0.1 uF	GRM15 series	MURATA	Decoupling capacitor
C2	0.1 uF	GRM15 series	MURATA	Decoupling capacitor
C3	1.5 pF	GRM15 series	MURATA	Harmonics reduction capacitor
C4	0.1 uF	GRM15 series	MURATA	Decoupling capacitor
C5	10 pF	GRM15 series	MURATA	DC blocking capacitor
C6	1 pF	GRM15 series	MURATA	PA output matching
C7	0.1 uF	GRM15 series	MURATA	Decoupling capacitor
C8	10 uF	GRM21 series	MURATA	Decoupling capacitor
C9	0.1 uF	GRM15 series	MURATA	Decoupling capacitor
L1	2 nH	LQG15HN series	MURATA	PA input matching
L2	27 nH	LQG15HN series	MURATA	PA output matching
L3	1 nH	LQG15HN series	MURATA	PA output matching
R1	10 Ω	MCR01 series	ROHM	PA input matching
S1	-	-	-	Micro-strip line (length = 2 mm, width = 0.4 mm)

Typical Operating Characteristics of Test Board 1 (PHS)

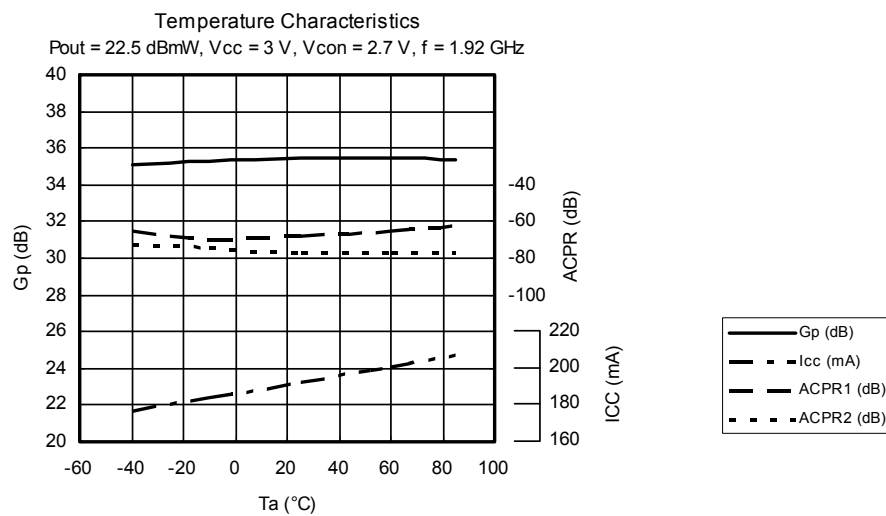
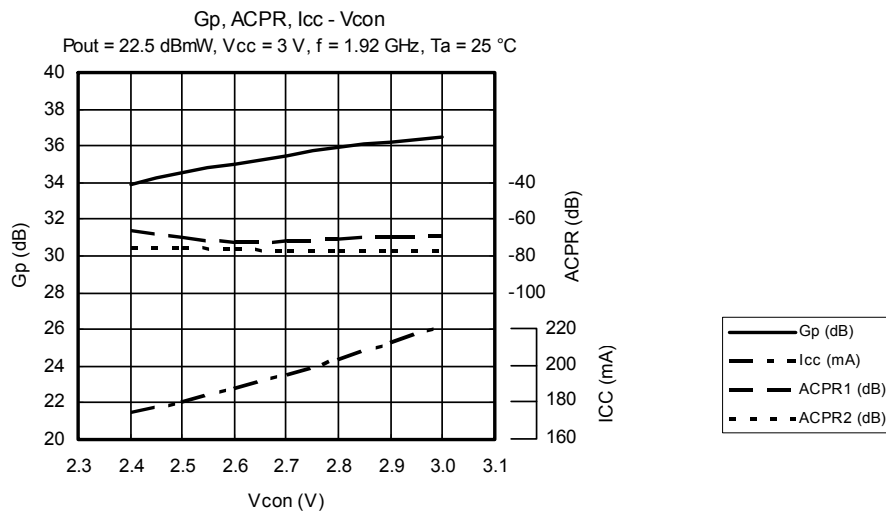
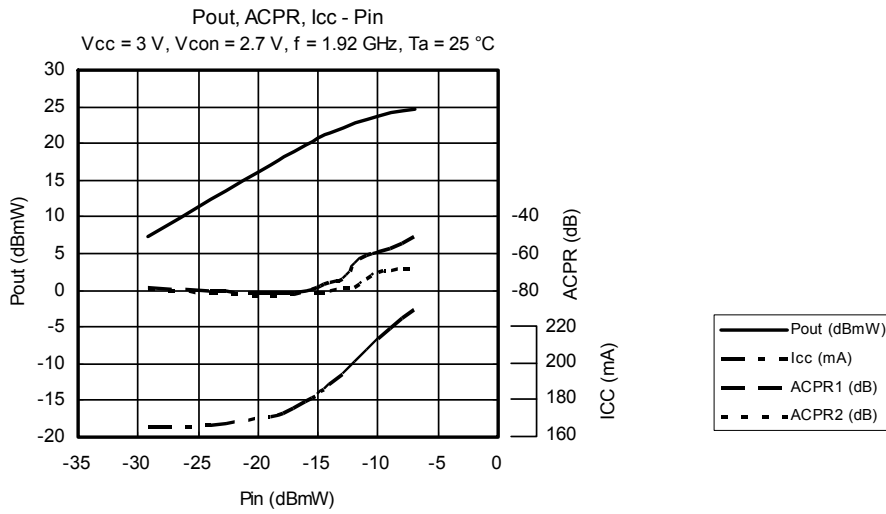

Typical Operating Characteristics of Test Board 2 (IEEE802.11g)

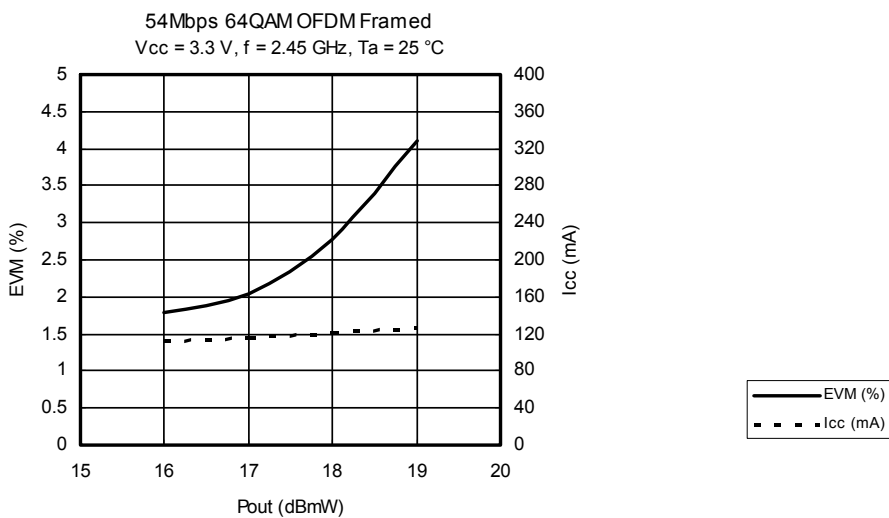
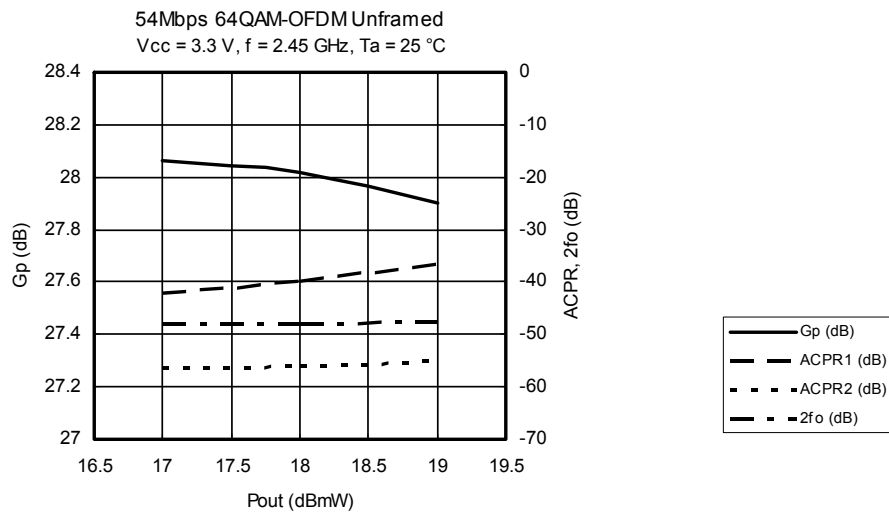
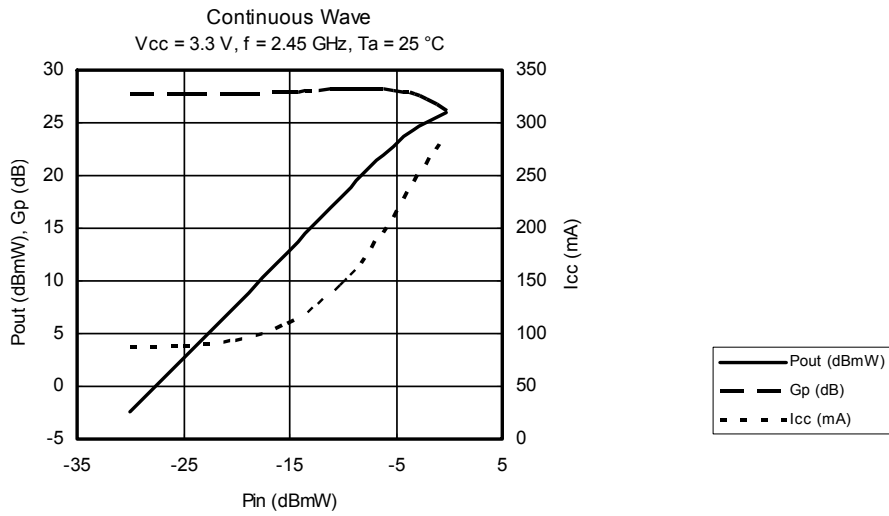

Notice

The circuits and measurements contained in this document are given only in the context of examples of applications for these products.

Moreover, these example application circuits are not intended for mass production, since the high-frequency characteristics (the AC characteristics) of these devices will be affected by the external components which the customer uses, by the design of the circuit and by various other conditions.

It is the responsibility of the customer to design external circuits which correctly implement the intended application, and to check the characteristics of the design.

TOSHIBA assume no responsibility for the integrity of customer circuit designs or applications.

Package Physical Dimensions

CST16

Unit: mm

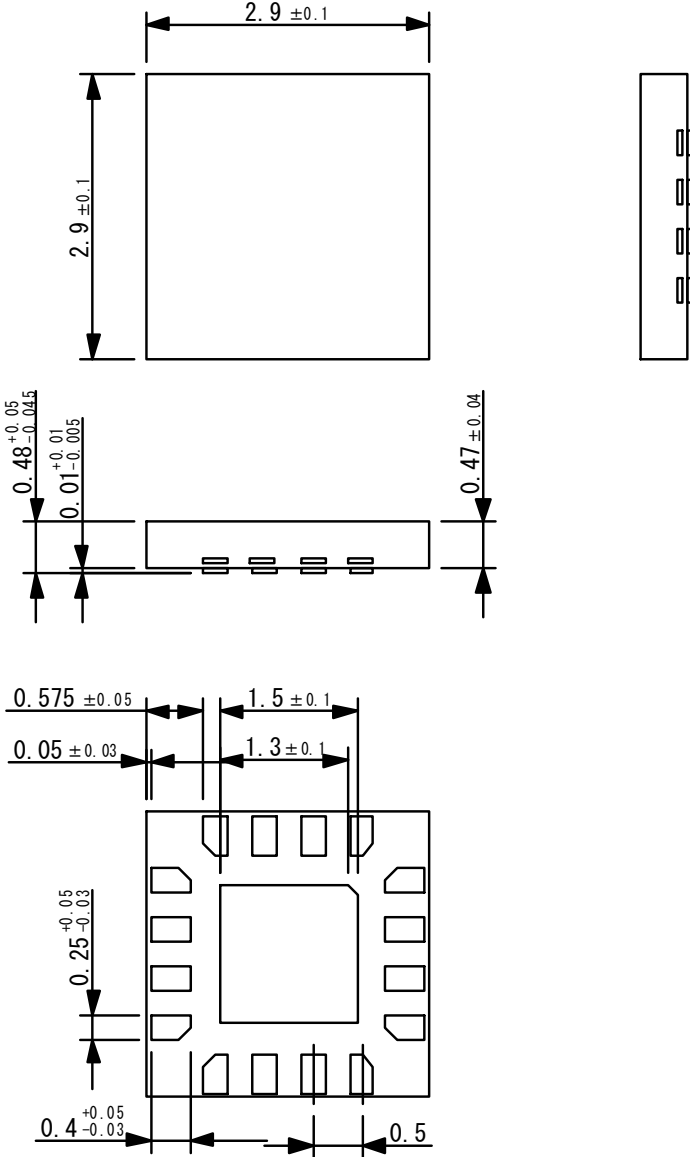

Weight: 0.012 g (typ.)

RESTRICTIONS ON PRODUCT USE

20070701-EN GENERAL

- The information contained herein is subject to change without notice.
- TOSHIBA is continually working to improve the quality and reliability of its products. Nevertheless, semiconductor devices in general can malfunction or fail due to their inherent electrical sensitivity and vulnerability to physical stress. It is the responsibility of the buyer, when utilizing TOSHIBA products, to comply with the standards of safety in making a safe design for the entire system, and to avoid situations in which a malfunction or failure of such TOSHIBA products could cause loss of human life, bodily injury or damage to property.
In developing your designs, please ensure that TOSHIBA products are used within specified operating ranges as set forth in the most recent TOSHIBA products specifications. Also, please keep in mind the precautions and conditions set forth in the "Handling Guide for Semiconductor Devices," or "TOSHIBA Semiconductor Reliability Handbook" etc.
- The TOSHIBA products listed in this document are intended for usage in general electronics applications (computer, personal equipment, office equipment, measuring equipment, industrial robotics, domestic appliances, etc.). These TOSHIBA products are neither intended nor warranted for usage in equipment that requires extraordinarily high quality and/or reliability or a malfunction or failure of which may cause loss of human life or bodily injury ("Unintended Usage"). Unintended Usage include atomic energy control instruments, airplane or spaceship instruments, transportation instruments, traffic signal instruments, combustion control instruments, medical instruments, all types of safety devices, etc.. Unintended Usage of TOSHIBA products listed in this document shall be made at the customer's own risk.
- The products described in this document shall not be used or embedded to any downstream products of which manufacture, use and/or sale are prohibited under any applicable laws and regulations.
- The information contained herein is presented only as a guide for the applications of our products. No responsibility is assumed by TOSHIBA for any infringements of patents or other rights of the third parties which may result from its use. No license is granted by implication or otherwise under any patents or other rights of TOSHIBA or the third parties.
- Please contact your sales representative for product-by-product details in this document regarding RoHS compatibility. Please use these products in this document in compliance with all applicable laws and regulations that regulate the inclusion or use of controlled substances. Toshiba assumes no liability for damage or losses occurring as a result of noncompliance with applicable laws and regulations.