

Film dielectric trimmers

2222 808

Ø10 mm

FEATURES

- Housing diameter 10 mm
- For a basic grid of 2.54 mm (0.1") or 2.50 mm
- Top and bottom or top adjustment
- Vertical and horizontal versions
- Round or hexagonal head.

APPLICATIONS

- For consumer and industrial equipment.

DESCRIPTION

The vanes of the trimmer are stacked on a sturdy plastic base. The colour of the base indicates the maximum capacitance (see Table 2). The dielectric is a film of polypropylene (PP), polycarbonate (PC) or polytetrafluorethylene (PTFE), which supports the vanes in such a way that good stability is ensured and no microphony can occur.

Flux absorption between the vanes is prevented.

Cleaning with solvents is not advised.

Versions are available with either a vertical spindle (see Figs 1 and 2), or a horizontal spindle (see Fig.3).

Both versions have top adjustment by means of a screwdriver or trimming key and bottom adjustment by means of a key as shown in Fig.7.

For outline drawings and dimensions see Figs 1, 2 and 3.

QUICK REFERENCE DATA

DESCRIPTION	VALUE
C_{min}/C_{max}	2.5/15 to 7/105 pF
Rated voltage (DC)	150 V
Test voltage (DC) for 1 minute	300 V
Maximum contact resistance	10 mΩ
Minimum insulation resistance	10000 MΩ
Category temperature range:	
PP	-40 to +70 °C
PC, PTFE	-40 to +85 °C
Climatic category (IEC 60068):	
PP	40/070/21
PC, PTFE	40/085/21
Minimum storage temperature	-55 °C
Related specification	IEC 60418-1 and 4

MECHANICAL DATA

DESCRIPTION	VALUE
Effective angle of rotation	180°
Operating torque	2 to 25 mNm
Maximum axial thrust	2 N

QUALITY LEVEL

Sampling and data evaluation for quality level in accordance with "MIL-STD-105D" and "IEC 60410":

- <0.15% major defects
- <0.65% minor defects.

Each capacitor is tested for minimum C_{max} and is also subjected to the full test voltage.

Film dielectric trimmers

2222 808
Ø10 mm

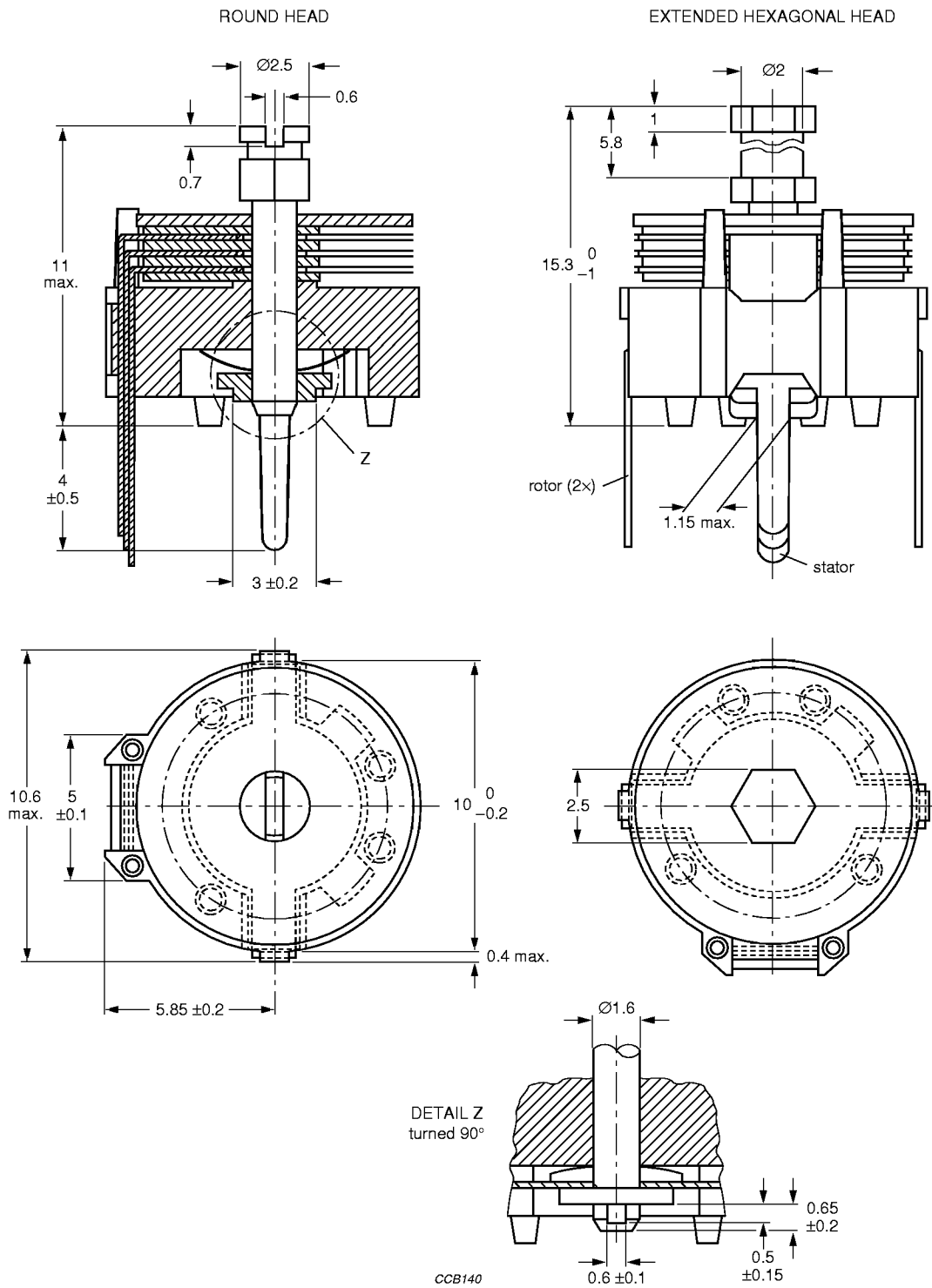

Dimensions in mm.
Hole pattern 5 mm x 10 mm; see Fig.4.

Fig.1 Trimmers 2222 808 series, vertical version.

Film dielectric trimmers

2222 808
 Ø10 mm

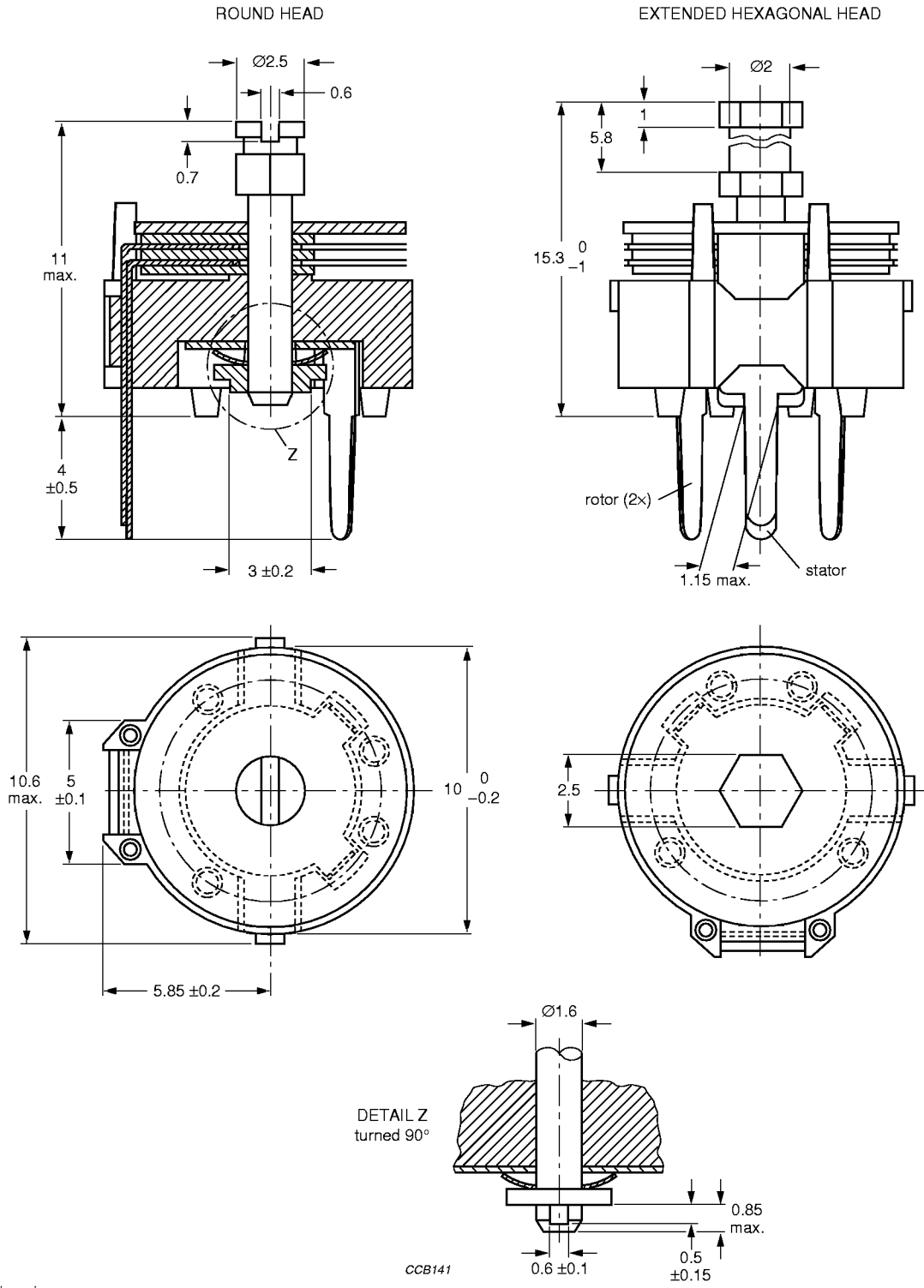

Dimensions in mm.
 Hole pattern 7.5 mm × 5 mm; see Fig.5.

Fig.2 Trimmers 2222 808 series, vertical version.

Film dielectric trimmers

2222 808
 Ø10 mm

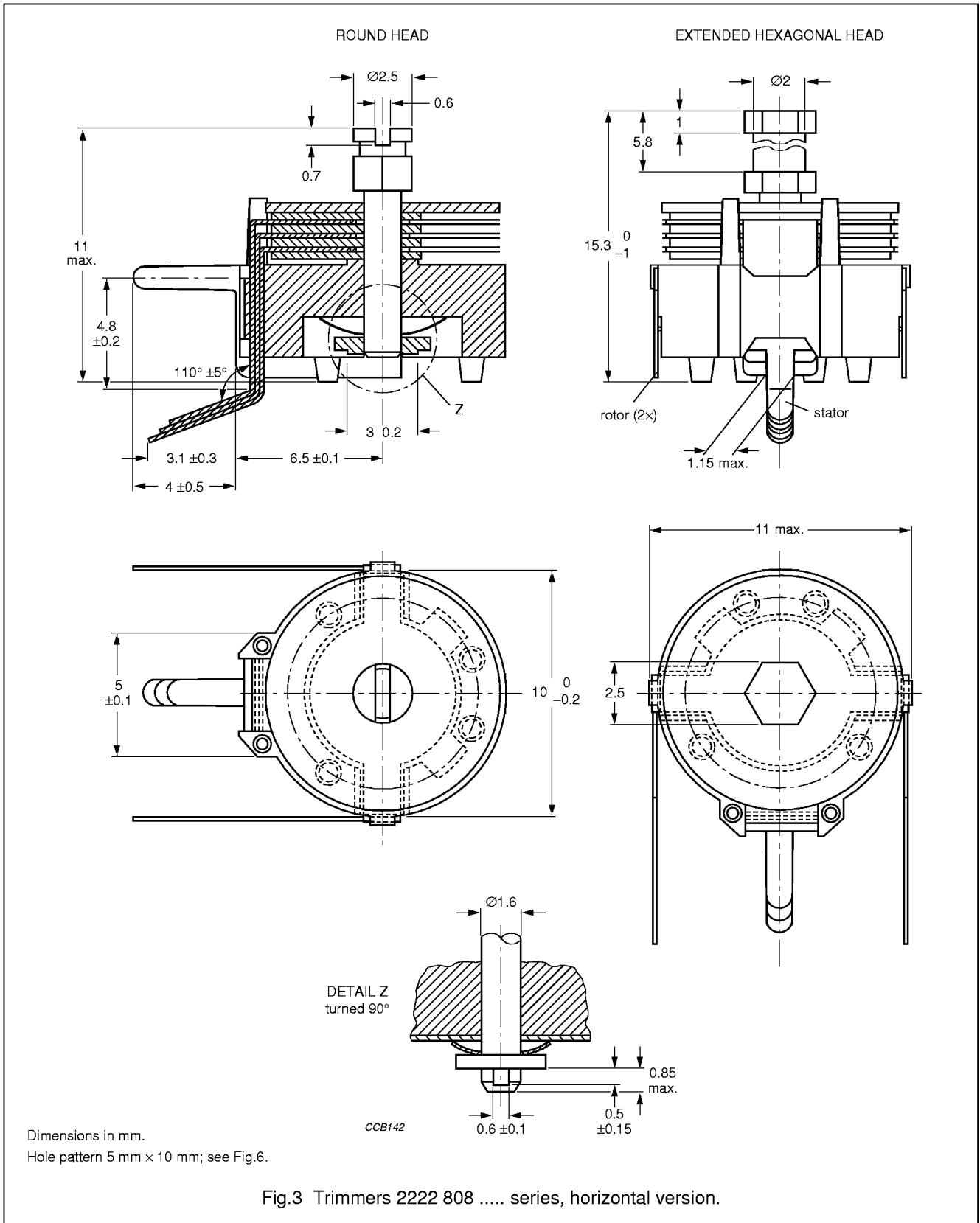
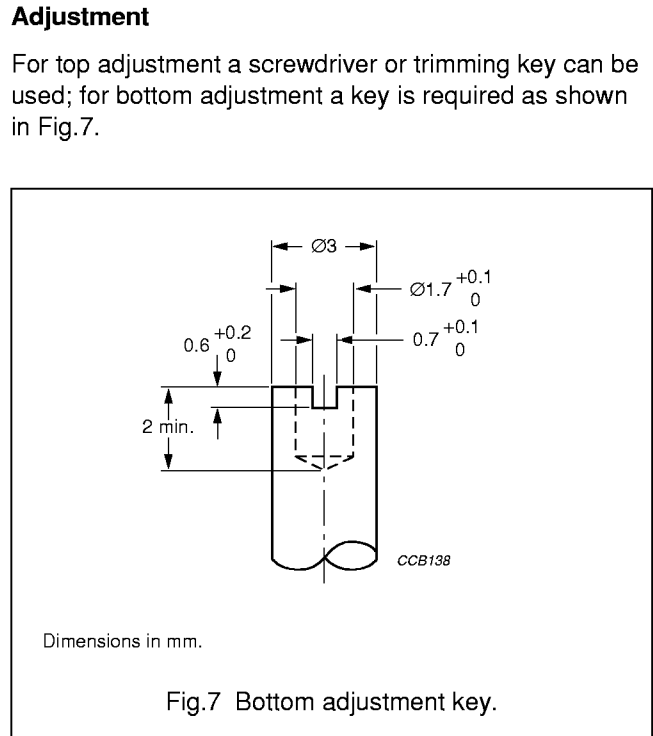
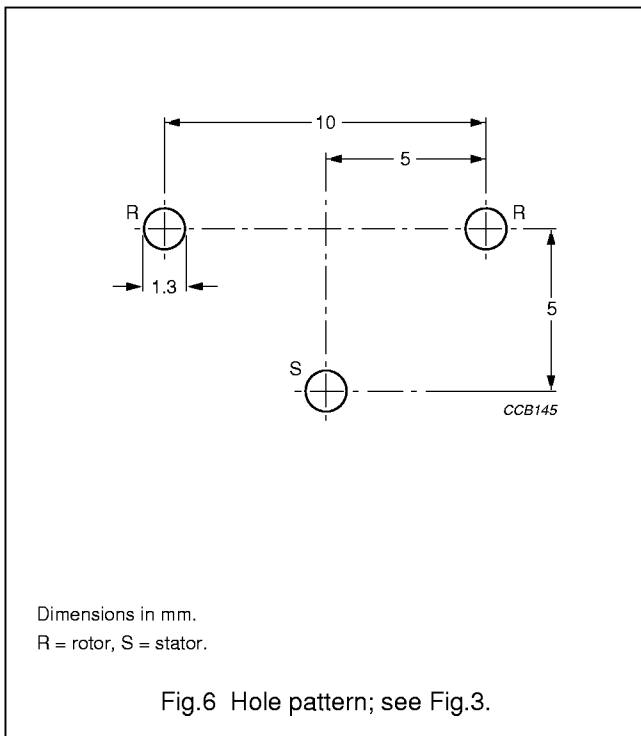
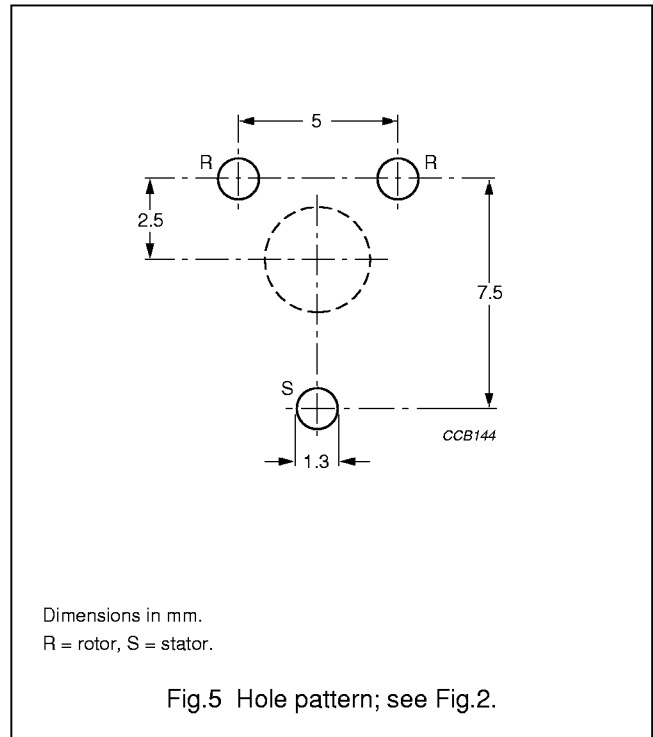
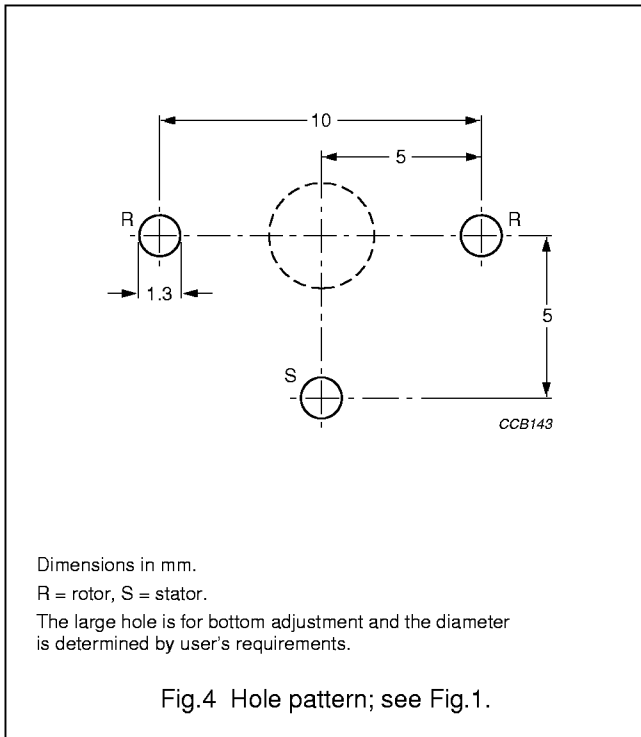

Fig.3 Trimmers 2222 808 series, horizontal version.

Film dielectric trimmers

2222 808
 Ø10 mm



Film dielectric trimmers

2222 808
Ø10 mm**ORDERING INFORMATION****Table 1** Selection chart

C_{min}/C_{max} (pF)	CATALOGUE NUMBER 2222 808						
	HORIZONTAL VERSION		VERTICAL VERSION				
	HOLE PATTERN 5 mm × 10 mm		HOLE PATTERN 5 mm × 10 mm		HOLE PATTERN 7.5 mm × 5 mm		
	ROUND HEAD	HEX HEAD	ROUND HEAD	HEX. HEAD	ROUND HEAD	HEX. HEAD	ROUND HEAD
	TOP AND BOTTOM ADJUSTMENT		TOP AND BOTTOM ADJUSTMENT				TOP ADJUSTMENT
2.5/15	61159	–	31159	–	32159	–	–
3/22.5	61229	–	31229	–	32229	–	–
5.5/40	61409	–	31409	–	32409	–	–
5.5/50	–	–	01029	–	01006	–	–
5.5/65	61659	64659	31659	34659	32659	–	01001
6/80	61809	64809	31809	34809	32809	35809	–
7/105	61101	64101	31101	–	32101	–	–
6/120	–	–	31121	–	–	–	–

MOUNTING

The trimmer can be mounted on printed-circuit boards with a grid of 2.50 mm or 2.54 mm and a minimum hole diameter of 1.25 mm. For hole patterns see Figs 4, 5 and 6.

PACKAGING

Bulk packaged in cardboard boxes lined with expanded plastic. For smallest packaging quantities (SPQ) see Table 2.

Film dielectric trimmers

2222 808
 Ø10 mm

ELECTRICAL DATA

Table 2 Electrical characteristics and catalogue numbers

GUARANTEED MAX. C _{min} / MIN. C _{max} at 200 kHz (pF)	SPINDLE	SHAPE OF HEAD	FIG.	ADJ. MODE	DIEL.	tan δ at C _{max} × 10 ⁻⁴		TEMP. COEFF. (10 ⁻⁶ /K)	MIN. f _{res} at C _{max} (MHz)	COL. OF BASE	SPQ	CATALOGUE NUMBER	
						1 MHz	100 MHz						
2.5/15	vertical	round	1	top + bottom	PP	≤10	≤25	-200 ±700	420	blue	800	2222 808 31159	
			2								800	2222 808 32159	
			3								700	2222 808 61159	
3/22.5	vertical	round	1	top + bottom	PP	≤10	≤25	-200 ±700	200	green	800	2222 808 31229	
			2								800	2222 808 32229	
			3								700	2222 808 61229	
5.5/40	vertical	round	1	top + bottom	PP	≤10	≤25	-200 ±400	200	grey	800	2222 808 31409	
			2								800	2222 808 32409	
			3								700	2222 808 61409	
5.5/50	vertical	round	1	top + bottom	PTFE	≤10	≤25	-200 ±400	170	yellow	800	2222 808 01029	
			2								800	2222 808 01006	
			2								800	2222 808 01001	
5.5/65	vertical	round	2	top + bottom	PP	≤10	≤25	-200 ±500	170	yellow	800	2222 808 31659	
			1								800	2222 808 32659	
			2								700	2222 808 34659	
		hexag.	round	1	top + bottom	PP	≤10	≤25	-200 ±500	170	yellow	700	2222 808 61659
				3								700	2222 808 61659
				3								600	2222 808 64659
6/80	vertical	round	1	top + bottom	PC	≤70	-	-50 ±400	170	red	800	2222 808 31809	
			1								700	2222 808 34809	
			2								800	2222 808 32809	
		hexag.	round	2	top + bottom	PC	≤70	-	-50 ±400	170	red	700	2222 808 35809
				2								700	2222 808 61809
				3								600	2222 808 64809
7/105	vertical	round	1	top + bottom	PC	≤70	-	-50 ±400	170	violet	800	2222 808 31101	
			2								800	2222 808 32101	
			3								700	2222 808 61101	
		hexag.	round	3	top + bottom	PC	≤70	-	-50 ±400	170	violet	600	2222 808 64101
				2								800	2222 808 31121
				2								800	2222 808 31121

Film dielectric trimmers

2222 808
 Ø10 mm

TESTS AND REQUIREMENTS

Table 3 Test procedures and requirements

IEC 60418-1 CLAUSE	IEC 60068 TEST METHOD	TEST	PROCEDURE	REQUIREMENTS
4.2		method of mounting	method A	
14		capacitance drift	after TC measurement	$\Delta C/C: \leq 4.5\%$ for $C_{max} < 40$ pF; $\Delta C/C: \leq 2.5\%$ for $C_{max} \geq 40$ pF
19		thrust	axial thrust of 2 N	$\Delta C/C: \leq 0.3\%$
21		robustness of terminations:		
21.1	Ua	tensile	1 N	no damage
21.2	Ub	bending	1 cycle	no damage
22	Na	rapid change of temperature	1 cycle; 0.5 hours at lower and 0.5 hours at upper category temperature	$\Delta C/C: \leq 1.5\%$
23	T	soldering:		
	Ta	solderability	solder bath immersion 3 mm; 235 °C; 2 s	good wetting no mechanical damage
	Tb	resistance to heat	solder bath: 260 °C; 10 s	no mechanical damage
24	Eb	impact bump	4000 ±10 bumps; 40 g; 6 ms	$\Delta C/C: \leq 0.4\%$; no mechanical damage
25	Fc	vibration	frequency 10 to 55 Hz; amplitude 0.35 mm; 1.5 hours	$\Delta C/C: \leq 0.8\%$; no mechanical damage
26		climatic sequence:		
26.1	B	dry heat	16 hours at upper category temperature	$\Delta C/C: \leq 3\%$ for $C_{max} < 80$ pF; $\Delta C/C: \leq 6\%$ for $C_{max} \geq 80$ pF $\tan \delta: \leq 15 \times 10^{-4}$ for $C_{max} < 80$ pF; $\tan \delta: \leq 80 \times 10^{-4}$ for $C_{max} \geq 80$ pF $R_{ins}: \geq 10000$ MΩ; rotor contact R: ≤ 10 mΩ
26.2	D	damp heat accelerated, first cycle	1 cycle; 24 hours; +40 °C; 95 to 100% RH	voltage proof: 300 V for 1 minute
26.3	Aa	cold	16 hours; -40 °C	visual examination: no mechanical damage
26.5		damp heat accelerated, remaining cycles	1 cycle; 24 hours; +40 °C; 95 to 100% RH	operating torque: 2 to 35 mNm

Film dielectric trimmers

2222 808
Ø10 mm

IEC 60418-1 CLAUSE	IEC 60068 TEST METHOD	TEST	PROCEDURE	REQUIREMENTS
27	Ca	damp heat steady state	21 days; +40 °C; 90 to 95% RH	$\Delta C/C$: $\leq 3\%$ for $C_{max} < 100$ pF; $\leq 3.5\%$ for $C_{max} \geq 100$ pF $\tan \delta$: $\leq 20 \times 10^{-4}$ for $C_{max} < 80$ pF; $\tan \delta$: $\leq 80 \times 10^{-4}$ for $C_{max} \geq 80$ pF R_{ins} : ≥ 10000 M Ω ; rotor contact R: ≤ 10 m Ω voltage proof: 300 V for 1 minute visual examination: no mechanical damage operating torque: 2 to 35 mNm
29		mechanical endurance	10 cycles	$\Delta C/C$: $\leq 1\%$ $\Delta C/C$ after axial thrust: $\leq 0.4\%$; rotor contact R: ≤ 10 m Ω voltage proof: 300 V for 1 minute visual examination: no mechanical damage operating torque: 1.5 to 37 mNm