

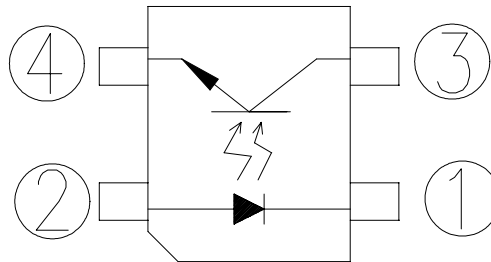

■ Package Dimensions :

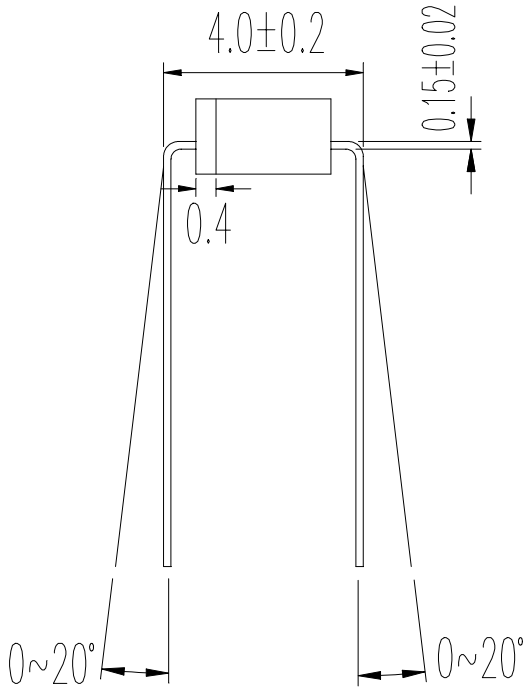
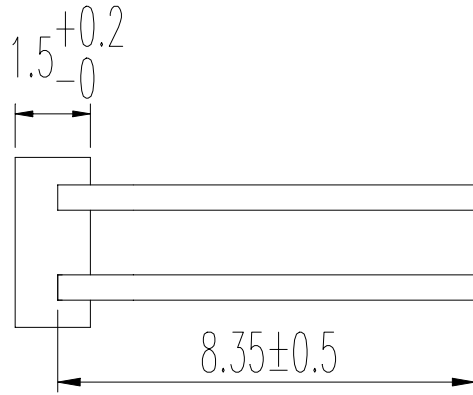
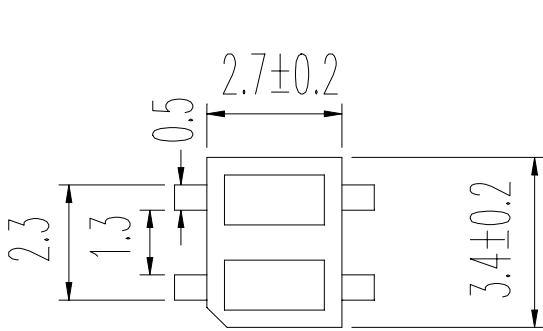

- ① :CATHODE      ③ :COLLECTOR
- ② :ANODE        ④ :EMITTER

DESIGNER	CHECKER	APPROVED

Office: NO 25,Lane 76,Chung Yang Rd,,Sec.3

Tucheng, Taipei 236,Taiwan, R.O.C.

TEL: 886-2-2267-2000,2267-9936(22Lines)

FAX: 886-2-2267-6189



■ **Notes :**

- 1.All dimensions are in millimeters.
- 2.General Tolerance:±0.15mm.
- 3.Lead spacing is measured where the lead emerge from the package.
- 4.Above specification may be changed without notice. EVERLIGHT will reserve authority on material change for above specification.
- 5.These specification sheets include materials protected under copyright of EVERLIGHT corporation. Please don't reproduce or cause anyone to reproduce them without EVERLIGHT's consent.
- 6.When using this product , please observe the absolute maximum ratings and the instructions for use outlined in these specification sheets. EVERLIGHT assumes no responsibility for any damage resulting from use of the product which does not comply with the absolute maximum ratings and the instructions included in these specification sheets.

■ **Descriptions:**

**EVERLIGHT Photo Interrupter** is a reflective type interrupter so the optimum detection distance: 1mm or less. This type (ITR8307/S17) is a black tint plastic package with top view and no lens ,the epoxy package spectrally matched to IR emitter ( $\lambda_p=940\text{nm}$ ), cutting wavelength under  $\lambda=840\text{nm}$

■ **Features:**

- Fast response time
- High sensitivity
- Cutting wavelength  $\lambda=840\text{nm}$
- Thin
- Compact

■ **Applications:**

- Camera
- VCR
- Floppy disk driver
- Cassette type recorder
- Various microcomputer control equipment



## Absolute Maximum Ratings (Ta=25°C)

Item		Symbol	Rating	Unit
Input	Power Dissipation	Pd	75	mW
	Reverse Voltage	V <sub>R</sub>	5	V
	Forward Current	I <sub>F</sub>	50	mA
	Peak Forward Current (*1)	I <sub>FP</sub>	1	A
Output	Collector Power Dissipation	Pc	100	mW
	Collector Current	Ic	50	mA
	Collector-Emitter Voltage	V <sub>CEO</sub>	30	V
	Emitter-Collector Voltage	V <sub>ECO</sub>	5	V
Operation Temperature		Topr	-20~+70	°C
Storage Temperature		Tstg	-30~+80	°C
Soldering Temperature (*2)		Tsol	260	°C

(\*1)  $t_w=100 \mu\text{Sec.}$  ,  $T=10 \text{mSec.}$  (\*2) 1/16 inch from body for 5 seconds

## Electro-optical Characteristics (Ta=25°C)

Parameter		Symbol	Min	Typ	Max	Unit	Condition	
Input	Forward Voltage	V <sub>F</sub>		1.2	1.6	V	I <sub>F</sub> =20mA	
	Reverse Current	I <sub>R</sub>			10	μA	V <sub>R</sub> =5V	
Output	Dark Current	I <sub>CEO</sub>			100	nA	V <sub>CE</sub> =20V Ee=0mW/cm <sup>2</sup>	
Transfer Characteristics	C-E Saturation Voltage		V <sub>CE(Sat)</sub>		0.4	V	Ic=0.5mA Ee=10mW/cm <sup>2</sup>	
	Light Current		I <sub>c(on) B</sub>	0.18	0.30	mA	V <sub>CE</sub> =5V I <sub>F</sub> =4.0mA	
			I <sub>c(on) C</sub>	0.25	0.44	mA	V <sub>CE</sub> =5V I <sub>F</sub> =10mA	
	Response Time	Rise Time	t <sub>r</sub>		20	---	μSec	V <sub>CC</sub> =5V I <sub>C</sub> =100 μA R <sub>L</sub> =1000Ω
		Fall Time	t <sub>f</sub>		20	---	μSec	



## ■ Typical Characteristics For IR

Fig. 1 Forward Current vs. Ambient Temperature

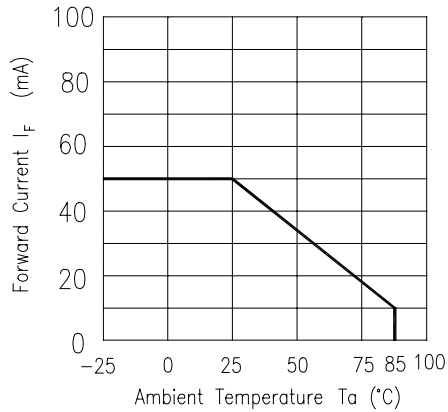

Fig. 2 Spectral Distribution

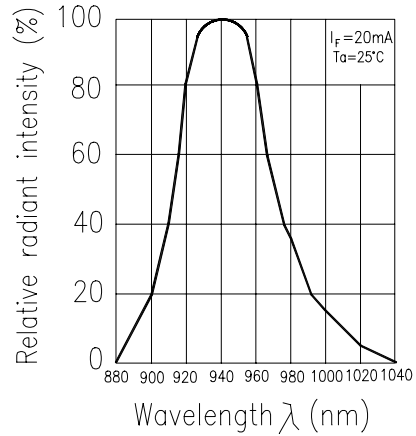

Fig. 3 Peak Emission Wavelength vs. Ambient Temperature

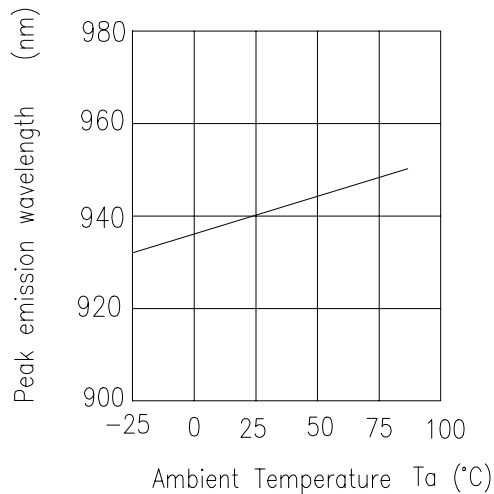

Fig. 4 Forward Current vs. Forward Voltage

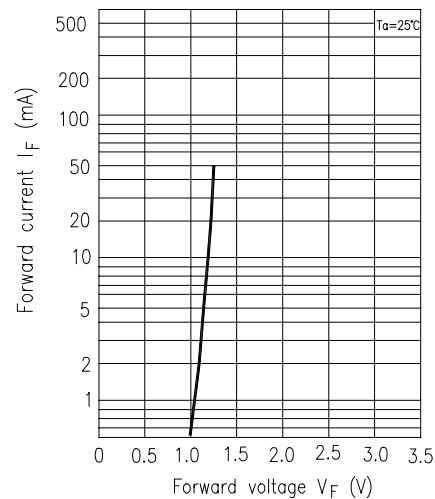

Fig. 5 Forward Voltage vs. Ambient Temperature

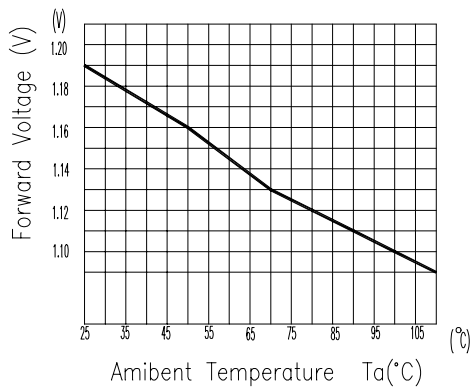
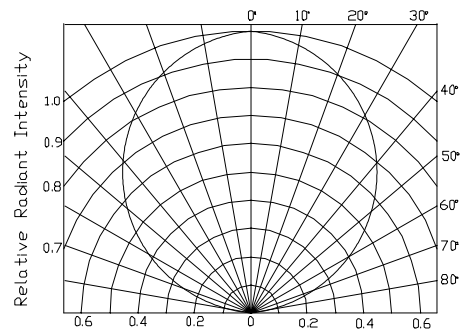

Fig. 6 Relative Radiant Intensity vs. Angular Displacement



## Typical Characteristics For ITR

Fig.7 Relative Collector Current vs. Distance between Sensor and Al Evaporation Galss

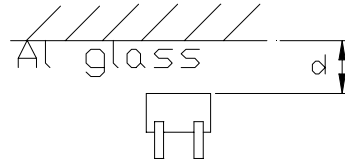
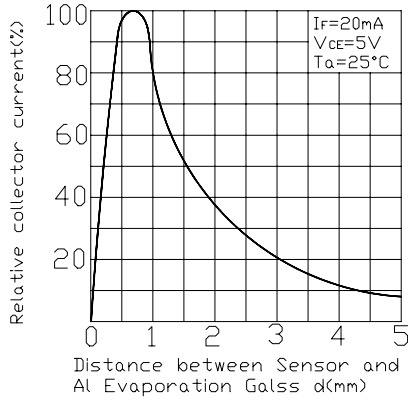

Fig.8 Relative Collector Current vs. Card Moving Distance (1)

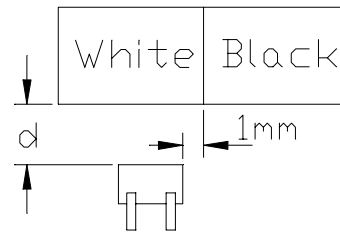
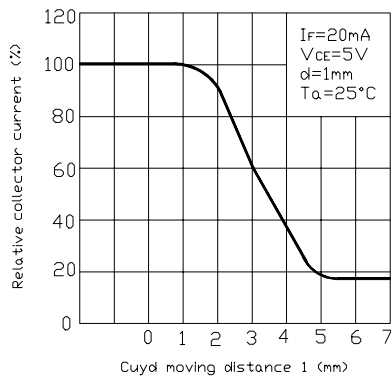
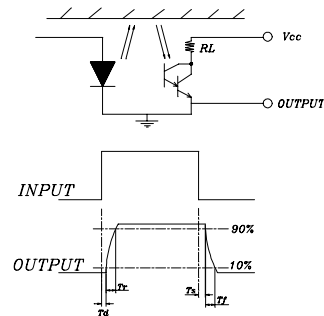
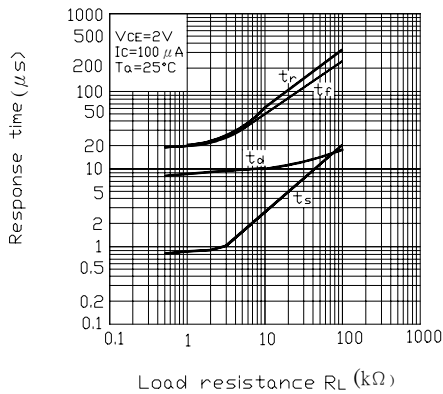

Fig.9 Response Time vs. Load Resistance





■ Reliability test item and condition

The reliability of products shall be satisfied with item listed below:

Confidence level :90%

LTPD:10%

Parameter	Purpose & Condition	Failure Judgement Criteria	Samples(n) Defective(
Temperature Cycle	Evaluates product's ability to withstand exposure to high temperature, low temperature, and temperature variation between two limit temperature. Standard test Condition: $\begin{matrix} 85^{\circ}\text{C} & \sim & 25^{\circ}\text{C} & \sim & -55^{\circ}\text{C} & \sim & 25^{\circ}\text{C} \\ \downarrow & & \downarrow & & \downarrow & & \downarrow \\ 30\text{min} & & 5\text{min} & & 30\text{min} & & 5\text{min} \end{matrix}$ 50 cycle	$I_R \geq U \times 2$ $I_{c(on)} \leq L \times 0.8$ $V_F \geq U \times 1.2$ U : Upper specification limit L : Lower specification limit	n =22 , c=0
Thermal Shock	Evaluates product's ability to withstand rapid temperature change Standard test Condition: $85^{\circ}\text{C} \sim -55^{\circ}\text{C}$ 5min (10 sec)5min 50cycle	U : Upper specification limit L : Lower specification limit	n =22 , c=0
High Temperature Storage	Evaluates product's ability to withstand prolonged storage at high temperature Standard test Condition: Temperature : 100 °C Time : 1000hrs		n =22 , c=0
Low Temperature Storage	Evaluates product's ability to withstand prolonged storage at low temperature Standard test Condition: Temperature : -55 °C Time : 1000hrs		n =22 , c=0



# EVERLIGHT ELECTRONICS CO., LTD.

Device Number: DRX-083-103 REV: 1.0

MODEL NO: ITR8307/S17

Ecn: \_\_\_\_\_

Page: 8 of 9

Parameter	Purpose & Condition	Failure Judgement Criteria	Samples(n) Defective(
Operating Life	Evaluates product's endurance to prolonged electrical or temperature stresses. Standard test Condition: $V_{CE}=5V$ $I_F=20mA$ Time : 1000hrs	$I_R \geq U \times 2$ $I_{c(on)} \leq L \times 0.8$ $V_F \geq U \times 1.2$  U : Upper specification limit  L : Lower specification limit	n =22 , c=0
High Temperature High Humidity	Evaluates product's ability to withstand prolonged storage at high temperature and high humidity. Standard test Condition: Temperature: 85°C Relative humidity:85% Time : 1000hrs		n =22 , c=0
Soldering Heat	Evaluates product's ability to withstand soldering heat Standard test conditions Solder temperature : Solder time : 5 seconds		n =22 , c=0

## ■Supplements

### 1.Parts

#### (1) Chip

Type	Material	Peak Wavelength
IR	GaAs	940 nm

Type	Material	Cutting Wavelength
PT	Silicon	840 nm

#### (2)Material

Type	Lead frame	Wire	Part Package
Material	Cu	Gold	Epoxy



■ Packing Specifications

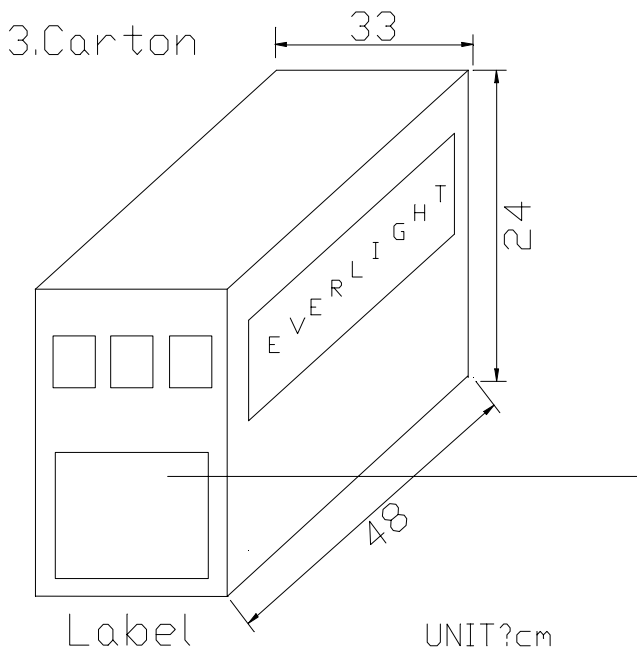
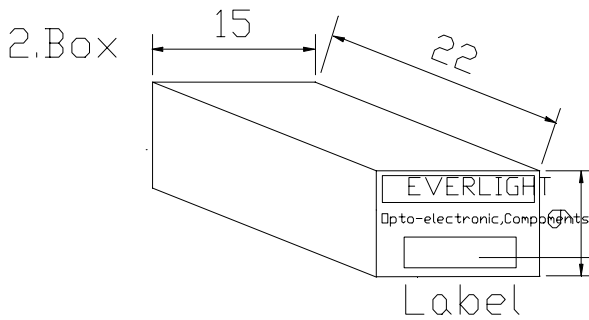
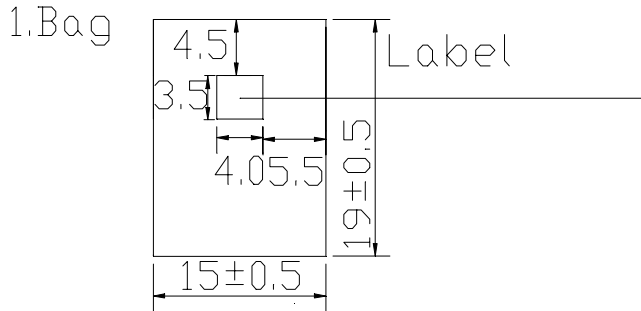

CPN:

P/N:

ITR8307/S17

QTY: 1000

LOT NO:

CAT:

HUE:

REF:

MADE IN TAIWAN

CPN : Customer's Production

P/N : Production Number

QTY : Packing Quantity

CAT : Ranks

HUE : Peak Wavelength

REF : Reference

LOT NO : Lot Number

MADE IN TAIWAN : Production place

■ Packing Quantity Specification

1. 1000Pcs/1Volume , 1Volume/1Bag

2. 10Bags/1Carton