

# MAXIM

## 10Gbps 16:1 Serializer

**MAX3952**

### General Description

The MAX3952 16:1 serializer is optimized for 10.3Gbps and 9.95Gbps Ethernet applications. A serial clock output is provided for retiming the data at the latch input of the laser driver. Both the high-speed data and clock are CML outputs. The serializer operates from a single +3.3V supply, consuming only 1.15W typical power.

The clock multiplier reference clock frequency can be either 1/16 or 1/64 the serial output clock rate. A FIFO aligns the phase between the parallel clock input and the internally synthesized clock. In addition, a 1/16 counterdirectional clock output (LVDS) is provided for use as the clock signal of the XAUI codec IC or framer.

The operating temperature range is from -40°C to +85°C. The MAX3952 is available in a 10mm x 10mm 68-pin QFN package.

### Features

- ◆ Operates at 9.953Gbps and 10.3125Gbps
- ◆ 16-Bit LVDS Interface
- ◆ Single +3.3V Supply
- ◆ 1.15W Power Dissipation
- ◆ LVDS Source Clock Output
- ◆ Built-In 2<sup>7</sup> - 1 PRBS Pattern Generator
- ◆ Deterministic Jitter: 9ps (max) at 0°C to +85°C
- ◆ Operating Temperature Range: -40°C to +85°C
- ◆ 68-Pin QFN Package (10mm x 10mm)

### Applications

- 10Gbps Ethernet LAN
- 10Gbps Ethernet WAN

### Ordering Information

PART	TEMP RANGE	PIN-PACKAGE
MAX3952EGK	-40°C to +85°C	68 QFN

Pin Configuration appears at end of data sheet.

### Typical Application Circuit

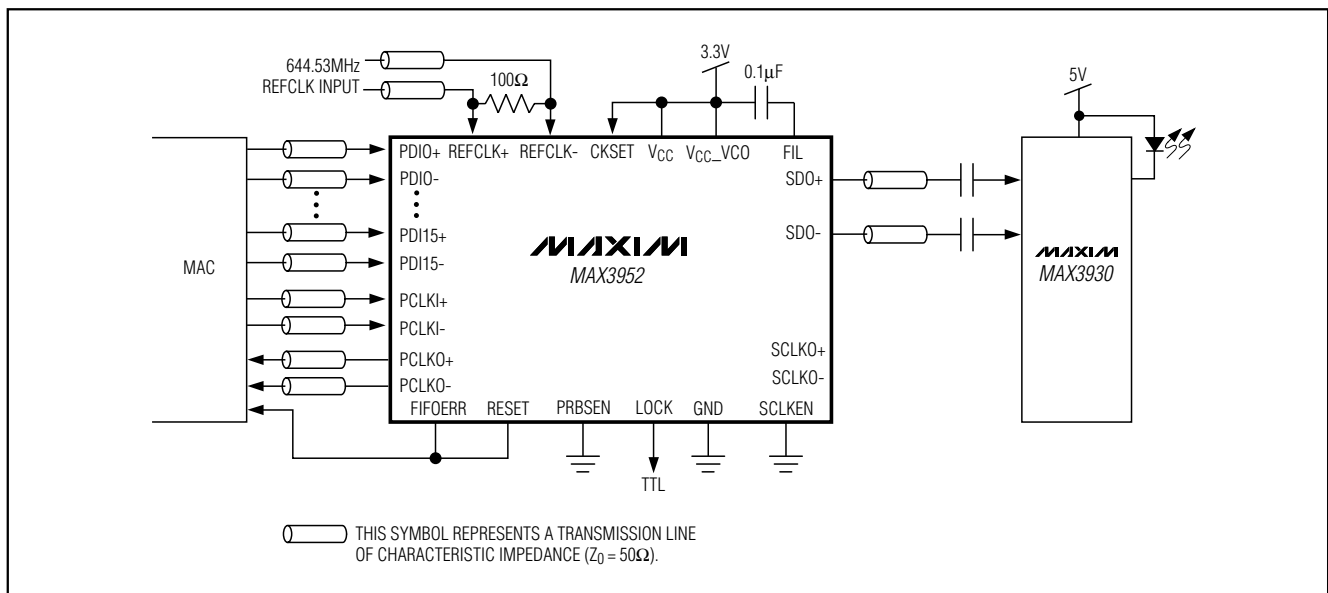

# 10Gbps 16:1 Serializer

## ABSOLUTE MAXIMUM RATINGS

Power Supply ( $V_{CC}$ ).....	-0.5 to +5V	Continuous Power Dissipation ( $T_A = +85^\circ\text{C}$ )	
CML Output Current ( $S_{DO\pm}$ , $S_{CLKO\pm}$ ).....	22mA	QFN (derate 30.3mW/ $^\circ\text{C}$ above $70^\circ\text{C}$ ).....	2424mW
LVDS Input Voltage Levels ( $P_{DI\pm}$ , $P_{CLKI\pm}$ ).....	-0.5V to ( $V_{CC} + 0.5\text{V}$ )	Operating Temperature Range .....	-40 $^\circ\text{C}$ to +85 $^\circ\text{C}$
LVDS Output Voltage ( $P_{CLKO\pm}$ ).....	-0.5V to ( $V_{CC} + 0.5\text{V}$ )	Storage Temperature Range .....	-65 $^\circ\text{C}$ to +160 $^\circ\text{C}$
		Voltage Levels at FIL, RESET, CKSET.....	-0.5V to ( $V_{CC} + 0.5\text{V}$ )
		Lead Temperature (soldering, 10s) .....	+300 $^\circ\text{C}$

Stresses beyond those listed under "Absolute Maximum Ratings" may cause permanent damage to the device. These are stress ratings only, and functional operation of the device at these or any other conditions beyond those indicated in the operational sections of the specifications is not implied. Exposure to absolute maximum rating conditions for extended periods may affect device reliability.

## DC ELECTRICAL CHARACTERISTICS

( $V_{CC} = +3\text{V}$  to +3.6V,  $T_A = -40^\circ\text{C}$  to +85 $^\circ\text{C}$ . Typical values are at  $V_{CC} = +3.3\text{V}$ , differential LVDS load = 100 $\Omega$ ,  $T_A = +25^\circ\text{C}$ , unless otherwise noted.)

PARAMETER	SYMBOL	CONDITIONS	MIN	TYP	MAX	UNITS
Supply Current	$I_{CC}$	(Note 1)		350	500	mA
<b>LVDS INPUT SPECIFICATIONS (<math>P_{DI\pm}[15\dots0]</math>, <math>P_{CLKI\pm}</math>)</b>						
Input Voltage Range	$V_I$		0		2400	mV
Differential Input Voltage	$ V_{ID} $		100			mV
Input Common-Mode Current		Input, $V_{OS} = 1.2\text{V}$		100		$\mu\text{A}$
Threshold Hysteresis				70		mV
Differential Input Impedance	$R_{IN}$		85	100	115	$\Omega$
<b>LVDS OUTPUT SPECIFICATIONS (<math>P_{CLKO\pm}</math>)</b>						
Output High Voltage	$V_{OH}$				1.475	V
Output Low Voltage	$V_{OL}$		0.925			V
Differential Output Voltage	$ V_{OD} $		250		400	mV
Change in Magnitude of Differential Outputs for Complementary Inputs	$\Delta V_{OD} $				25	mV
Offset Output Voltage			1.125		1.275	V
Change in Magnitude of Output Offset Voltage for Complementary States	$\Delta V_{OS} $				25	mV
Differential Output Impedance			80		140	$\Omega$
Output Current		Short together			12	mA
		Short to ground			40	

# 10Gbps 16:1 Serializer

MAX3952

## DC ELECTRICAL CHARACTERISTICS (continued)

( $V_{CC} = +3V$  to  $+3.6V$ ,  $T_A = -40^{\circ}C$  to  $+85^{\circ}C$ . Typical values are at  $V_{CC} = +3.3V$ , differential LVDS load =  $100\Omega$ ,  $T_A = +25^{\circ}C$ , unless otherwise noted.)

PARAMETER	SYMBOL	CONDITIONS	MIN	TYP	MAX	UNITS
<b>CML OUTPUT SPECIFICATIONS (SDO<math>\pm</math>, SCLKO<math>\pm</math>)</b>						
Differential Output		$R_L = 50\Omega$ to $V_{CC}$	640	800	1000	mV <sub>P-P</sub>
Differential Output Impedance			85	100	115	$\Omega$
Output Common-Mode Voltage		$R_L = 50\Omega$ to $V_{CC}$		$V_{CC} - 0.2$		V
<b>LVTTTL SPECIFICATIONS (RESET, FIFO_ERROR, LOCK, PRBSEN)</b>						
LVTTTL Input High Voltage	$V_{IH}$		2.0			V
LVTTTL Input Low Voltage	$V_{IL}$				0.8	V
LVTTTL Input High Current	$I_{IH}$		-28		10	$\mu A$
LVTTTL Input Low Current	$I_{IL}$		-50		10	$\mu A$
LVTTTL Output High Voltage	$V_{OH}$	$I_{OH} = 20\mu A$	2.4		$V_{CC}$	V
LVTTTL Output Low Voltage	$V_{OL}$	$I_{OL} = 1mA$			0.4	V
<b>LVPECL INPUT SPECIFICATIONS (REFCLK<math>\pm</math>)</b>						
LVPECL Input High Voltage	$V_{IH}$		$V_{CC} - 1.16$		$V_{CC} - 0.88$	V
LVPECL Input Low Voltage	$V_{IL}$		$V_{CC} - 1.81$		$V_{CC} - 1.48$	V
LVPECL Input Bias Voltage				$V_{CC} - 1.3$		V
LVPECL Single-Ended Impedance				1.4		k $\Omega$
LVPECL Differential Input Voltage Swing			300		1900	mV <sub>P-P</sub>

**Note 1:** CML outputs AC-coupled to  $100\Omega$  differential load, PRBSEN = GND, and SCLKEN = GND.

# 10Gbps 16:1 Serializer

## AC ELECTRICAL CHARACTERISTICS

( $V_{CC} = +3V$  to  $+3.6V$ ,  $T_A = -40^{\circ}C$  to  $+85^{\circ}C$ . Typical values are at  $V_{CC} = +3.3V$ , differential LVDS and CML load =  $100\Omega$ ,  $T_A = +25^{\circ}C$ , unless otherwise noted.) (Note 2)

PARAMETER	SYMBOL	CONDITIONS	MIN	TYP	MAX	UNITS
<b>Tx DATA INPUT SPECIFICATIONS (PDI<math>\pm</math>[15...0], PCLKI<math>\pm</math>)</b>						
Parallel Input Setup Time	$t_{SU}$	(Figure 1)			200	ps
Parallel Input Hold Time	$t_H$	(Figure 1)			200	ps
<b>Tx SOURCE CLOCK OUTPUT SPECIFICATIONS (PCLKO<math>\pm</math>)</b>						
Parallel Clock Output Rise/Fall Time	$t_r, t_f$	20% to 80%		100	250	ps
Parallel Clock Output Duty Cycle			45		55	%
<b>SERIAL DATA OUTPUT SPECIFICATIONS (SDO<math>\pm</math>, SCLKO<math>\pm</math>)</b>						
Bit-Error Rate			$1 \times 10^{-12}$			
Serial Data Output Rise/Fall Time	$t_r, t_f$	20% to 80%			28	ps
Serial Output Clock-to-Data Delay	$t_{CK-Q}$	(Note 3)	-15		+15	ps
Serial Data or Clock Output Random Jitter	$t_{RJ}$				0.9	pSRMS
Serial Data Output Deterministic Jitter	$t_{DJ}$	0°C to +85°C (Note 4)			9	pSP-P
		-40°C to +85°C (Note 4)			15	
Serial Clock or Data Output Return Loss	RL = $-20\log S_{22} $	100kHz to 10GHz			17	dB
		10GHz to 13GHz			10	
		13GHz to 15GHz			7	
<b>Tx REFERENCE CLOCK INPUT SPECIFICATIONS (REFCLK<math>\pm</math>)</b>						
Reference Clock Frequency Tolerance			-100		+100	ppm
Reference Clock Input Duty Cycle			30		70	%
<b>RESET INPUT (RESET)</b>						
Minimum Pulse Width of FIFO Reset		UI is PCLKO period			4	UI
Tolerated Drift Between PCLKI and PCLKO After Reset		UI is PCLKO period; drift is PCLKO crossing - PCLKI crossing	-1		+1	UI

**Note 2:** See Table 1 for valid operating clock frequencies. AC characteristics are guaranteed by design and characterization.

**Note 3:** Relative to the falling edge of the SCLKO.

**Note 4:** Deterministic jitter includes pattern-dependent jitter and pulse-width distortion. Measured with a pattern equivalent to  $2^{23} - 1$  PRBS.

# 10Gbps 16:1 Serializer

## Typical Operating Characteristics

( $T_A = +25^\circ\text{C}$ ,  $V_{CC} = +3.3\text{V}$ , unless otherwise noted.)

MAX3952

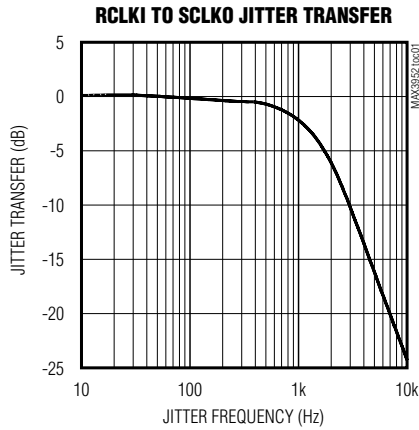

### SERIAL CLOCK OUTPUT RANDOM JITTER

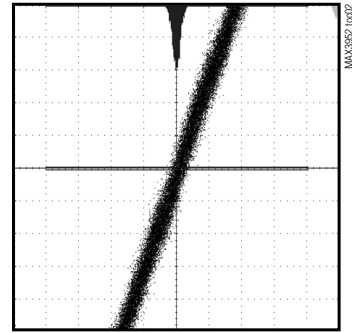

$f_{\text{REFCLK}} = 155.52\text{MHz}$ , RANDOM JITTER = 513fs<sub>RMS</sub>

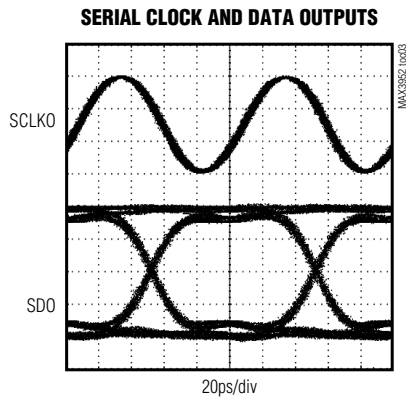

### SUPPLY CURRENT vs. TEMPERATURE

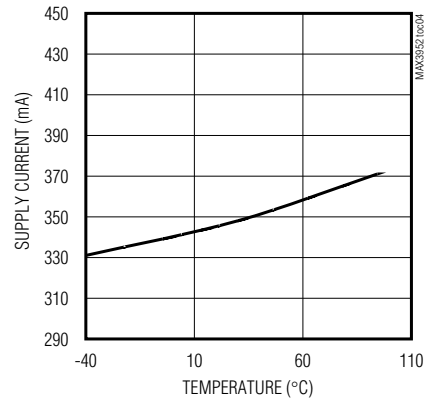

# 10Gbps 16:1 Serializer

**MAX3952**

## Pin Description

PIN	NAME	FUNCTION
1, 4, 5, 13, 17, 18, 26, 34, 35, 51, 52, 68	GND	Ground
2	REFCLK+	Positive Reference Clock Input, LVPECL
3	REFCLK-	Negative Reference Clock Input, LVPECL
6, 9, 12, 25, 43, 60	VCC	Positive Power Supply
7	SCLKO-	Negative Serial Clock Output, CML. 9.95328GHz or 10.3125GHz
8	SCLKO+	Positive Serial Clock Output, CML. 9.95328GHz or 10.3125GHz
10	SDO-	Negative Serial Data Output, CML. 9.95328Gbps or 10.3125Gbps
11	SDO+	Positive Serial Data Output, CML. 9.95328Gbps or 10.3125Gbps
14	SCLKEN	Control Input for Disabling SCLKO Output: SCLKEN = GND ⇒ SCLKO Off SCLKEN = VCC ⇒ SCLKO Active
15	PCLKO+	Positive Source Clock Output. LVDS, 622MHz or 644MHz. Clocks the MAC.
16	PCLKO-	Negative Source Clock Output. LVDS, 622MHz or 644MHz. Clocks the MAC.
19, 21, 23, 27, 29, 31, 36, 38, 40, 44, 46, 48, 54, 56, 58, 61	PDI15+ to PDI0+	Positive Parallel Data Inputs, LVDS. PDI15+ is MSB
20, 22, 24, 28, 30, 32, 37, 39, 41, 45, 47, 49, 55, 57, 59, 62	PDI15- to PDI0-	Negative Parallel Data Inputs, LVDS. PDI15- is MSB
33	RESET	16 x 4-Bit FIFO Reset Input, TTL, Active High
42	PRBSEN	PRBS Pattern Generator Enable Input, TTL, Active High
50	FIFO_ERROR	FIFO Error, TTL, Active High
53	LOCK	PLL Lock Indicator, TTL, Active High
63	PCLKI+	Positive Parallel Clock Input, LVDS
64	PCLKI-	Negative Parallel Clock Input, LVDS
65	CKSET	Reference Clock Programming Pin. Programming instructions in Table 1.
66	FIL	Filter Capacitor Input Pin
67	VCC_VCO	Loop Filter and VCO Positive Power Supply

# 10Gbps 16:1 Serializer

## Detailed Description

The MAX3952 converts 16-bit-wide, 622Mbps/644Mbps data to 9.95Gbps/10.3Gbps serial data (Figures 3 and 4). Data is loaded into the 16:1 mux through a 16 x 4 FIFO buffer for wide tolerance to clock skew. Clock and data inputs are LVDS levels, and high-speed serial outputs are current-mode logic (CML). An internal PLL frequency synthesizer generates a serial clock from a low-speed reference clock.

### Low-Voltage Differential-Signal Inputs and Outputs

The MAX3952 has LVDS inputs for interfacing with high-speed digital circuitry. This technology uses 250mV to 400mV differential low-voltage swings to achieve fast transition times, minimal power dissipation, and noise immunity. For proper operation, the parallel clock LVDS outputs (PCLKO±) require 100Ω differential DC terminations between the positive and negative outputs. Do not terminate these outputs to ground. The parallel data and parallel clock LVDS inputs (PDI+, PDI-, PCLKI+, PCLKI-) are internally terminated with a 100Ω differential input resistance and therefore do not require external termination.

### LVPECL Inputs

The reference clock (REFCLK±) has LVPECL inputs for interfacing to a crystal oscillator using AC- or DC-coupling. The REFCLK± inputs are self-biasing to VCC - 1.3V for AC-coupled inputs. Only a 100Ω differential termination resistance must be added when inputs are AC-coupled.

### Current-Mode Logic Outputs

The high-speed data and clock outputs (SDO±, SCLKO±) of the MAX3952 are designed using CML. The CML outputs include internal 50Ω back termination to VCC. These outputs are intended to drive a 50Ω transmission line terminated with a matched load impedance. For detailed instructions on how to interface with LVDS, PECL, and CML, refer to HFAN-01.0: *Introduction to LVDS, PECL, and CML*.

### FIFO Buffer

Data is latched into the MAX3952 by the parallel input clock (PCLKI±). The parallel input clock is the FIFO write clock. The parallel output clock (PCLKO±) is the FIFO read clock that loads the 16:1 mux. The FIFO allows the read and write clock to vary by up to ±1UI (unit interval). This specification makes the MAX3952 noncompliant with the IEEE802.3ae standard, as this standard requires a tolerance of ±14UI. Conditions that result in the read and write clock accessing the same FIFO address are indicated by FIFO\_ERROR. To clear

this condition, assert RESET high for at least 4UI. FIFO\_ERROR can be connected directly to the RESET input to clear timing errors. After reset, the full elastic range of the FIFO is available again.

### Frequency Synthesizer

The PLL synthesizes a 9.95GHz/10.31GHz clock from an external reference clock. The PLL reference clock (REFCLK±) can be programmed as 622MHz/644MHz or 155MHz/161MHz using the CKSET pin. See Table 1 for CKSET settings. The parallel output clock (PCLKO±) is derived from the synthesizer and is SCLKO ÷ 16. A TTL-compatible loss-of-lock indicator (LOCK), asserts low when the VCO is unable to lock to the reference frequency. This pin can be used to directly drive an LED. If jitter on the REFCLK± input is present, an error with respect to the divided down SCLKO frequency of 500ppm will be indicated by a low state on LOCK.

**Table 1. Setting REFCLK Frequency**

REFERENCE CLOCK FREQUENCY (MHz)	CKSET PIN SETTING	SERIAL CLOCK FREQUENCY (GHz)
622.08	OPEN	9.95
644.53	VCC	10.3
155.52	GND	9.95
161.13	30kΩ to GND	10.3

### Internal Pattern Generator

The MAX3952 includes a SONET-compliant internal pattern generator capable of a 2<sup>7</sup> - 1 PRBS pattern. Connecting the PRBSEN pin to VCC enables the pattern generator.

### Layout Techniques

For best performance, use good high-frequency layout techniques. Filter voltage supplies and keep ground connections short. Use multiple vias where possible. Use controlled impedance transmission lines to interface with the MAX3952 clock and data inputs and outputs. Give special consideration to filtering the VCC\_VCO pin; all other power supplies can be connected through a common filter.

### Exposed Pad (EP) Package

The EP 68-pin QFN incorporates features that provide a very low thermal resistance path for heat removal from the IC to a PC board. The MAX3952's exposed paddle must be soldered directly to a ground plane with good thermal conductance. Refer to HFAN-08.1: *Thermal Considerations of QFN and Other Exposed-Paddle Packages*.

# 10Gbps 16:1 Serializer

## Chip Information

TRANSISTOR COUNT:8400

PROCESS: SiGe bipolar

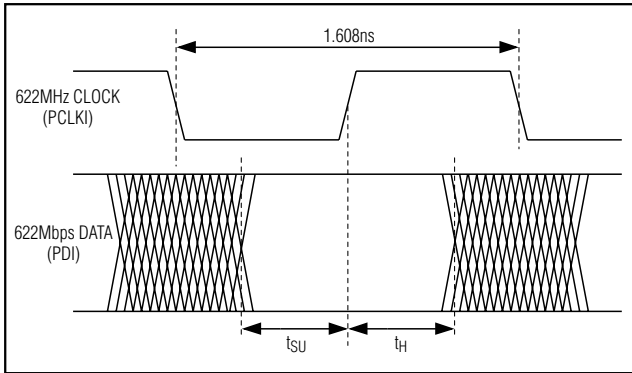

Figure 1. Setup and Hold Time

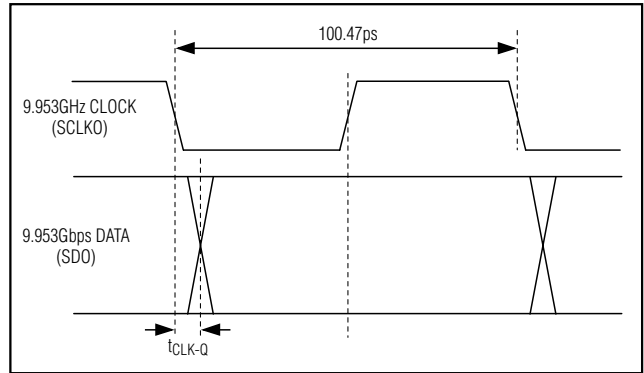

Figure 2. Definition of Clock to Q

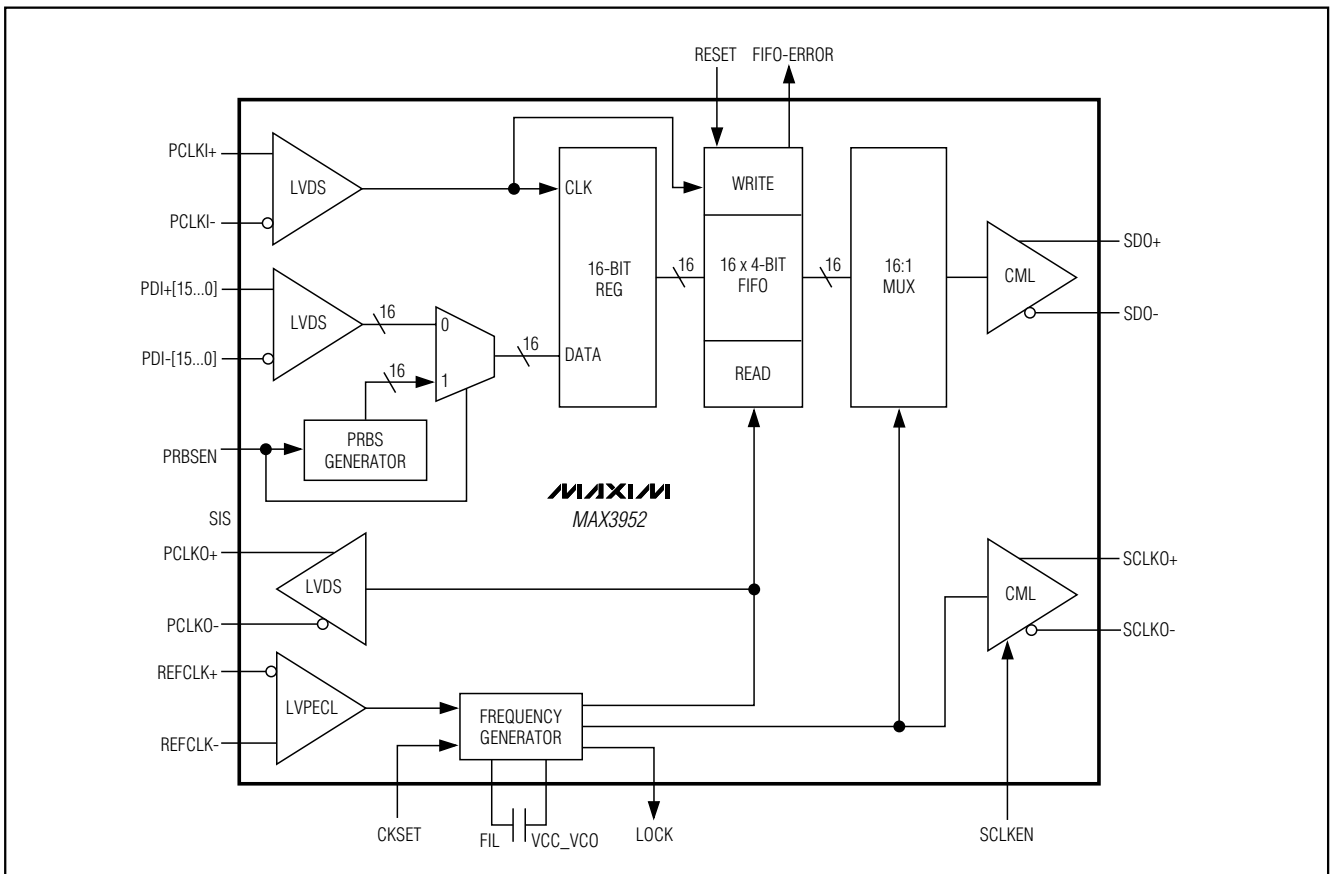

Figure 3. Functional Diagram

# 10Gbps 16:1 Serializer

**MAX3952**

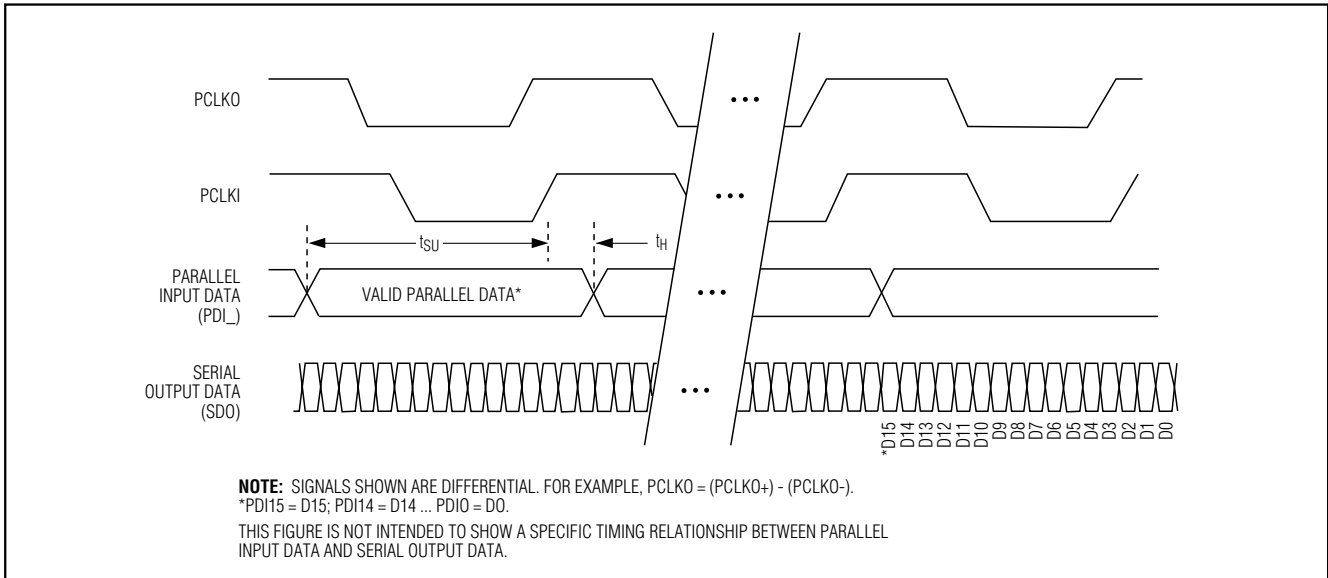
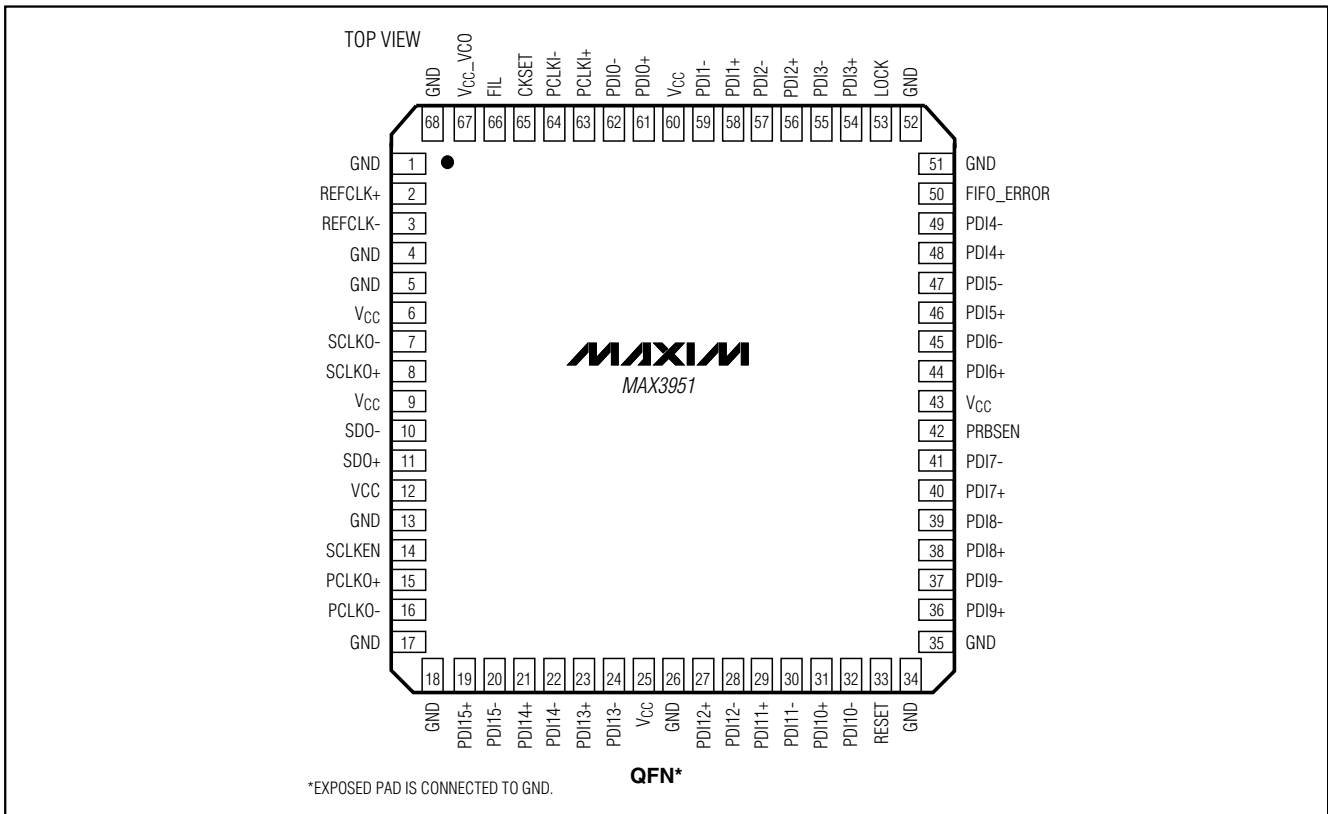

Figure 4. Parallel and Serial Data Timing

## Pin Configuration



# 10Gbps 16:1 Serializer

## Package Information

(The package drawing(s) in this data sheet may not reflect the most current specifications. For the latest package outline information, go to [www.maxim-ic.com/packages](http://www.maxim-ic.com/packages).)

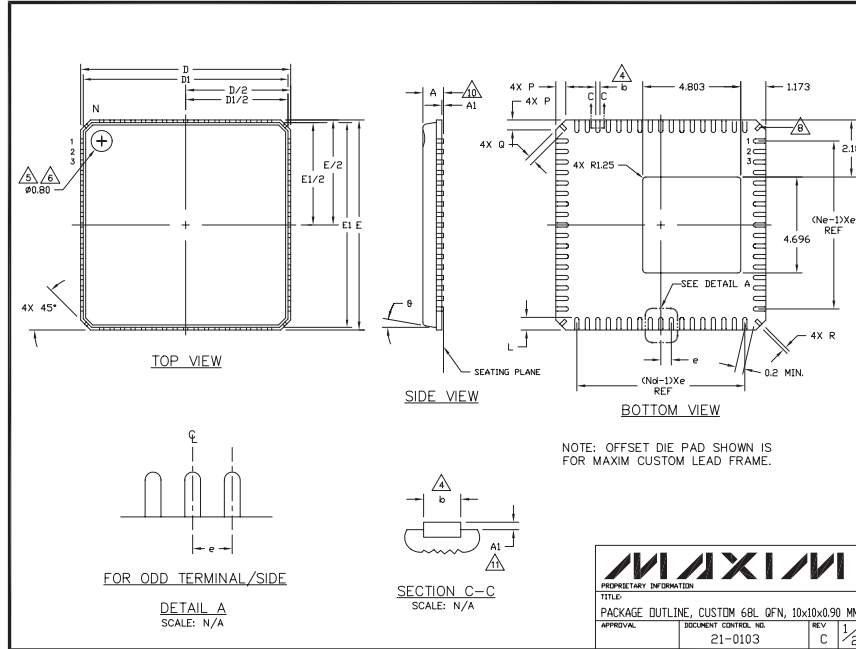

**NOTES:**

- DIE THICKNESS ALLOWABLE IS .012 INCHES MAXIMUM.
- DIMENSIONING & TOLERANCES CONFORM TO ASME Y14.5M. - 1994.
- N IS THE NUMBER OF TERMINALS.  
Nd IS THE NUMBER OF TERMINALS IN X-DIRECTION & Ne IS THE NUMBER OF TERMINALS IN Y-DIRECTION.
- DIMENSION b APPLIES TO PLATED TERMINAL AND IS MEASURED BETWEEN 0.20mm AND 0.25mm FROM TERMINAL.
- THE PIN #1 IDENTIFIER MUST BE LOCATED ON THE TOP SURFACE OF THE PACKAGE BY USING INDENTATION MARK OR OTHER FEATURE OF PACKAGE BODY.
- EXACT SHAPE AND SIZE OF THIS FEATURE IS OPTIONAL.
- ALL DIMENSIONS ARE IN MILLIMETERS.
- THE SHAPES SHOWN AT FOUR CORNERS ARE CONNECTED TO DIE PAD.
- PACKAGE WARPAGE MAX 0.10mm.
- APPLIED FOR EXPOSED PAD AND TERMINALS.
- APPLIED ONLY FOR TERMINALS.
- CUSTOM LEAD FRAME WITH OFFSET DIE PAD: REFER TO MAXIM 24-0718 (G6800-1F).

Symbol	COMMON DIMENSIONS			No. of Terminals
	MIN.	NOM.	MAX.	
A		0.90	1.00	
A1	0.00	0.01	0.05	11
b	0.18	0.23	0.30	4
D	10.00BSC			
D1	9.75BSC			
E	10.00BSC			
E1	9.75BSC			
N	68			3
Nd	17			3
Ne	17			3
Ⓢ	0.50 BSC			
L	0.50	0.60	0.75	
Ⓟ	12°			
P	0.24	0.42	0.60	
Q	0.30	0.40	0.65	
R	0.13	0.17	0.23	

<b>MAXIM</b>			
PROPRIETARY INFORMATION			
TITLE: PACKAGE OUTLINE, CUSTOM 68L QFN, 10x10x0.90 MM			
APPROVAL:	DOCUMENT CONTROL NO:	REV:	
	21-0103	C	2/2

Maxim cannot assume responsibility for use of any circuitry other than circuitry entirely embodied in a Maxim product. No circuit patent licenses are implied. Maxim reserves the right to change the circuitry and specifications without notice at any time.

10 **Maxim Integrated Products, 120 San Gabriel Drive, Sunnyvale, CA 94086 408-737-7600**

SITE  
SEARCHPART NO.  
SEARCH

WHAT'S NEW

PRODUCTS

SOLUTIONS

DESIGN

APPNOTES

SUPPORT

BUY

COMPANY

MEMBERS

## MAX3952

### Part Number Table

**Notes:**

1. See the [MAX3952 QuickView Data Sheet](#) for further information on this product family or download the [MAX3952 full data sheet](#) (PDF, 304kB).
2. Other options and links for purchasing parts are listed at: <http://www.maxim-ic.com/sales>.
3. [Didn't Find What You Need?](#) Ask our applications engineers. Expert assistance in finding parts, usually within one business day.
4. Part number suffixes: T or T&R = tape and reel; + = RoHS/lead-free; # = RoHS/lead-exempt. More: See [full data sheet](#) or [Part Naming Conventions](#).
5. \* Some packages have variations, listed on the drawing. "PkgCode/Variation" tells which variation the product uses.

Part Number	Free Sample	Buy Direct	Package: TYPE PINS SIZE DRAWING CODE/VAR *	Temp	RoHS/Lead-Free? Materials Analysis
MAX3952EGK-TD	<input type="checkbox"/>	<input type="checkbox"/>		-40C to +85C	RoHS/Lead-Free: <a href="#">No</a>
MAX3952EGK-D	<input type="checkbox"/>	<input type="checkbox"/>	QFN;68 pin;10x10x0.9mm Dwg: <a href="#">21-0103D</a> (PDF) Use pkgcode/variation: G6800-1F*	-40C to +85C	RoHS/Lead-Free: <a href="#">No</a> <a href="#">Materials Analysis</a>

[Didn't Find What You Need?](#)[CONTACT US: SEND US AN EMAIL](#)