

MA589 FAMILY

LD/DTMF SWITCHABLE DIALLERS WITH DEDICATED KEYS FOR 20 MEMORIES

The MA589 family are keypad switchable LD/DTMF dialler devices with a last number redial facility and twenty 24-digit memories, each with its own dedicated dialling key.

Three operating modes are available: LD only mode, DTMF only mode and LD mode with the ability to switch temporarily to DTMF mode from the keypad during a call. This last mode enables subscribers to access such services as home banking Mixed LD and DTMF numbers can also be stored in memory.

The-MA589 devices are pin compatible with the GPS switchable dialler families MA526, MA527, MA541, MA545 MA547, MA585 and MA587 - providing a complete range of telephone features within a single PCB and circuit design. Metal mask and pin selectable options are available to service specific requirements of particular countries and customers.

FEATURES

- Selectable Loop-Disconnect or DTMF Modes
- Keypad Switchable LD to DTMF
- 20 X24-Digit Memories, each with Dedicated Key
- 24 Digit Last Number Redial
- Selectable Make/Break Ratios 2:1 and 3:2
- Uses Inexpensive 560kHz Ceramic Resonator
- Battery-less operation - Low Power CMOS
- Mask Programmable Options to suit Application
- Timed Break Recall (Flash) and Earth Recall

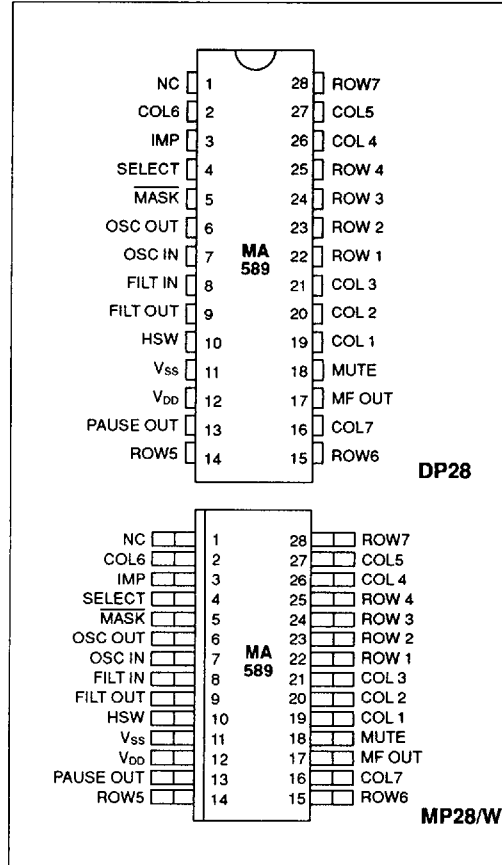

Figure 1: Pin connections - top view. (not to scale)

PIN FUNCTIONS

Pin number	Pin name	Function
1	NC	Not connected
3 4 5	IMP SELECT MASK	'Loop disconnect' dialling output LD/DTMF selection, IDP and B/M radio programming Output to disable speech circuit during pulse dialling and recall (see note 1)
6 7	OSC OUT OSC IN	Connections for 560kHz ceramic resonator
8 9	FILT IN FILT OUT	Unity gain amplifier input and output for DTMF tone filtering
10 11 12 13 17 18	HSW V _{ss} V _{DD} PAUSE OUT MF OUT MUTE	Hookswitch input - a logic 1 at this pin is used to indicate 'Off-hook' Negative supply Positive supply Active high output indicating a pause when dialling from memory Unfiltered DTMF output Output active during keying and tone transmission (see note 2)
19 20 21 26 27 2 16 22 23 24 25 14 15 28	COL1 COL2 COL3 COL4 COL5 COL6 COL7 ROW1 ROW2 ROW3 ROW4 ROW5 ROW6 ROW7	Connections for 38 key single contact keypad

1. MASK may be used to disconnect the whole speech circuit in order to maintain the break condition whilst on-hook and during a TBR (Timed Flash) operation
2. MUTE is provided to disable the microphone while maintaining the loop condition during DTMF transmission

Table 1. Pin functions

OPERATION

Power-on

When power is applied to the chip, a power-on reset circuit operates and ensures that the last number redial store is cleared and all logic is reset. The power-on reset circuit is designed such that if the chip supply voltage drops to a level at which the LNR store may be corrupted, it will always, under all conditions, clear the store when power is restored, so that corrupt data is not retained

Hookswitch Operation

The HSW input is used to inform the MA589 of whether the telephone is on or off hook. Logic '0' is recognised as on-hook, Logic '1' is recognised as off-hook. When the HSW input rises from '0' to '1' the off-hook state is recognised immediately and keypad inputs are accepted. However, when the HSW input falls from '1' to '0' the onhook state is not recognised for 200-300ms. This is so that short line breaks of less than 200ms, such as line reversals applied by the exchange, are ignored. In this case the IMP and MASK outputs will go low immediately the HSW input goes low in order to preserve current, but will resume normal operation immediately HSW goes high

On-hook state

In the on-hook state all chip outputs are set low, the oscillator circuit is inhibited and no key inputs are accepted. This conserves supply current so that the LNR store contents may be retained

Off-hook state

When the HSW input goes high, the MASK output immediately goes to the logic '1' level and remains there until going on-hook or signalling a TBR, (see timing diagram). COLUMN outputs also go high until a key is pressed. The oscillator circuit remains inactive until a key is pressed, and is normally off whenever timing functions are not required

Keypad Operation

A single contact, normally open keypad is required. When off-hook the COLUMN outputs are normally held high and the ROW inputs are low. When a key is pressed this connects a COLUMN output to a ROW input and the ROW input is pulled high.

This action initiates keyboard scanning. During keyboard scanning, the COLUMN outputs are normally low but generate scanning pulses at 7ms intervals on each output in sequence. A key is accepted as valid when, two successive scanning pulses from the same COLUMN are seen on a ROW input. Hence, the minimum bounce-free key closure period which is necessary to guarantee detection is about 14ms (plus the oscillator start-up time if it was not already running)

Simultaneous key depressions

If two keys are pressed simultaneously (i.e. a second key is pressed before the first has been verified) neither key will be accepted until both keys are released and the correct key is pressed again.

Dialling Mode Selection

The dialling mode may be selected via the SELECT pin (pin 4) as detailed in Table 2 Four 'LoopDisconnect + DTMF' options and four 'Loop-Disconnect only' options with different Interdigit pauses and Break/Make ratios are available and one DTMF mode. If one of the 'LD only' modes or the DTMF mode is selected then dialling will remain fixed in LD mode or DTMF mode respectively.

	COL 1	COL 2	COL 3	COL 4	COL 5	COL 6	COL 7
ROW 1	1	2	3	TBR	S1	S2	S3
ROW 2	4	5	6	REDIAL	S4	S5	S6
ROW 3	7	8	9	STORE	S7	S8	S9
ROW 4	*	0	#	PAUSE/ CONT	SHIFT	S00	LNR
ROW 5					S11	S12	S13
ROW 6				S10	S14	S15	S16
ROW 7					S17	S18	S19

Figure 2a: Versions without TONE key

* or # are used to change from LD to DTMF dialling and are available as digits when in DTMF mode

TBR Timed Break Recall (Flash)

STORE Memory Programming key. Use in conjunction with dedicated memory keys or a two-digit code representing the number of the memory to be programmed.

S00 - S19 'Single-touch' dedicated memory dialling keys

LNR Last Number Redial

REDIAL and SHIFT These keys are clearly unnecessary where keypad positions are provided for all the dedicated memory keys but may be useful to access memories in applications where the telephone provides insufficient keys for all these functions. For a description of the function of the REDIAL and SHIFT keys, see the MA585 and MA587 datasheets, respectively. Do not fit keys in these positions if not required.

PAUSE/CONT: Insert pause in memory/continue dialling

TONE: Change dialling mode from LD to DTMF

	COL 1	COL 2	COL 3	COL 4	COL 5	COL 6	COL 7
ROW 1	1	2	3	TBR	S1	S2	S3
ROW 2	4	5	6	REDIAL	S4	S5	S6
ROW 3	7	8	9	STORE	S7	S8	S9
ROW 4	*	0	#	TONE	SHIFT	S00	LNR
ROW 5					S11	S12	S13
ROW 6				S10	S14	S15	S16
ROW 7					S17	S18	S19

Figure 2b: Versions with TONE key

Figure 2: Keypad layout and connections

However, if one of the 'LD + DTMF~' modes is selected, the chip will be in LD mode initially in the off-hook condition but may be switched to DTMF by pressing either the *, */# or TONE key (depending on the mask variant - see Fig 2 and page 1-65), provided that dialling is not in progress. If any of these keys are pressed during LD dialling, they will be ignored.

Only if * or # are pressed subsequent to switching to DTMF, will * or # be dialled. Only digits entered prior to a switch to DTMF will subsequently be available for redialling (see Last Number Redial operation).

Once switched to DTMF, dialling will remain in this mode until either a Recall (Flash) operation or until the chip returns to the on-hook state.

SELECT pin to	Dialling mode	IDP (ms)	B/M ratio
V _{SS}	LD + DTMF	800	2:1
COL 1	LD + DTMF	500	2:1
COL 2	LD + DTMF	500	3:2
COL 3	LD + DTMF	800	3:2
COL 4	LD only	800	2:1
COL 5	LD only	500	2:1
COL 6	LD only	500	3:2
COL 7	LD only	800	3:2
V _{DD}	DTMF	-	-

Table 2: Dialling mode selection

Last Number Redial (LNR)

The function of the on-chip LNR store is to retain automatically a manually dialled number for redialling later. The capacity of the store is 24 digits. If a number is dialled which is longer than this, redialling will not be allowed with this number. To redial a number in the LNR store, the LNR key must be pressed once.

The last number redial store has several features designed to assist the user:

Moving cursor facility

This allows a user to enter the first digit or digits of the number in the last number redial store manually before pressing the LNR key; the remainder of the number will be dialled when the LNR key is pressed.

If the digit(s) dialled manually do not match those in the LNR store, then redialling will be inhibited for the remainder of the call, and the numbers entered will be saved in the LNR store for redialling in a subsequent call.

If the user manually dials the first digit(s) in the LNR store, and then goes on-hook, the whole contents of the store will be retained.

This facility is provided to aid use in PABX applications, where the user must first dial an access digit, or digits, and then wait for a second dial tone before continuing dialling.

Mixed Mode Calls

In the case of a call which starts in LD mode and is switched by the user (via the *, */#, or TONE key) to DTMF mode, only the digits dialled in LD mode will be retained. This feature is provided to ensure security of PIN (Personal Identification Number) codes. Provided that the number of digits dialled in LD mode does not exceed 24, they will be retained regardless of the number of DTMF digits entered subsequently.

Memory Dialling

The MA589 provides 20 memories, each of which has a capacity of 24 digits and each of which has its own dedicated key. The memories can store digits to be dialled in LD, DTMF or mixed modes and also pauses.

Programming Memories

The MA589 must be 'off-hook' and idle:

1. Press the STORE key.
2. Press the key (S00-S19) of the memory to be programmed.
3. Enter digits to be stored (no digits will be dialled whilst programming)
4. To finish programming the memory either press the STORE key again or go 'on-hook'
5. Repeat to programme other memories

If more than 24 digits are entered while programming a memory, then the memory will be cleared until reprogrammed. If any non-valid keys are pressed during programming (e.g. LNR, TBR) they will be ignored

Mixed mode numbers and pauses in memory

Mixed mode (ie LD + DTMF) numbers are easily programmed into memory. The SELECT pin should be set to one of the 'LD + DTMF' modes (as it would be when dialling a mixed mode number), then the number entered using the same procedure as if dialling normally. The first press of *, */# or TONE (according to the mask variant) will be stored as a 'change to DTMF', and this will cause all subsequent digits to be sent in DTMF when redialling from memory

Similarly, pauses can be stored in memory by pressing the PAUSE key in the appropriate position when programming

When redialling from memory, both pauses and LD to DTMF changeovers will cause dialling to halt temporarily until the user presses the PAUSE/CONT key. The exception to this rule is when an LD to DTMF changeover is stored in the first memory location: in this case, DTMF dialling will occur immediately when memory dialling is invoked - this allows DTMF codes to be easily stored and sent even in a telephone where the normal dialling mode is LD

It should be noted that a pause or an LD to DTMF changeover each require one memory location.

Dialling from memories

The MA589 must be 'off-hook' and idle:

1. Press the appropriate dedicated memory key (S00-S19). Dialling will now start.
2. If dialling halts due to a pause or an LD to DTMF changeover in the memory, the PAUSE OUT pin will go high (logic '1').

Further dialling can be resumed either by pressing the PAUSE/CONT key or, alternatively, the Column 4 pin can be pulled low (for a minimum of 14 ms) to achieve the same result, thus allowing an external timer circuit to be used. The PAUSE/OUT output is reset when dialling resumes.

All keypad positions are disabled whilst memory dialling is in progress

Timed Break & Earth Loop Recall (Flash)

The MA589 supports both TBR and ELR and offers a common operating protocol in both cases

After a recall (Flash) operation the dialling mode selected via the SELECT pin will be restored. Also, only the digits dialled after the ELR/TBR operation will be retained in the LNR store⁽¹⁾.

A TBR (Flash) of 100ms⁽²⁾ is generated when the TBR key is pressed. The MASK output goes low in order to produce the line break. When in DTMF mode, the MF OUT output also goes low for the duration of the break

ELR is supported via the column 3 pin. If this pin is connected to ground for a minimum of 20ms during an ELR operation, the chip will offer the same operating protocol as for TBR

This may be achieved by use of the circuit shown below in Fig 3, or by use of a double contact switch

⁽¹⁾ Other options are available including an option for Danish requirements (see page 1-65). In Denmark TBR (or ELR) is used to obtain an outside line in PABX use. Under these conditions the LNR store contents will be retained and can be redialled after a TBR or ELR. Digits manually entered after a TBR or ELR will become the new LNR store contents

⁽²⁾ Other TBR (Flash) periods are available as mask options (see page 1-65)

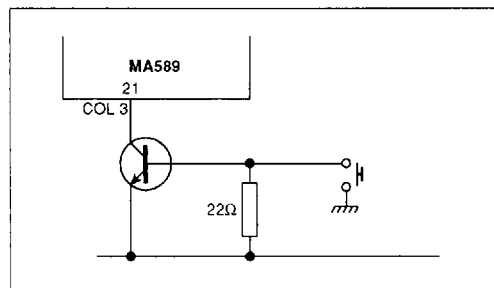

Figure 3 Earth loop recall

Oscillator Circuit

This requires an external 560kHz ceramic resonator connected between OSC IN and OSC OUT to provide a timing reference for all chip functions. No other components are required or should be used.

The oscillator circuit is of the 'single pin' type. Internally, the OSC IN pin is connected to V_{SS} and therefore the resonator may alternatively be connected externally between OSC OUT and V_{SS} if desired.

Please consult your resonator supplier who will recommend a suitable resonator type.

Tone Filtering

The spectral purity of the DTMF output is sufficient for most applications. However, where lower distortion DTMF tones are required, an on-chip darlington pair is provided (accessible via pins 7 & 8) for use in a low pass active filter.

Fig. 4 shows how a 2-pole Sallen and Key filter can be implemented. The typical component values have been chosen to give a second order Butterworth response with a cut-off frequency of about 3.5kHz and a nominal pass-band insertion loss of 0.5dB.

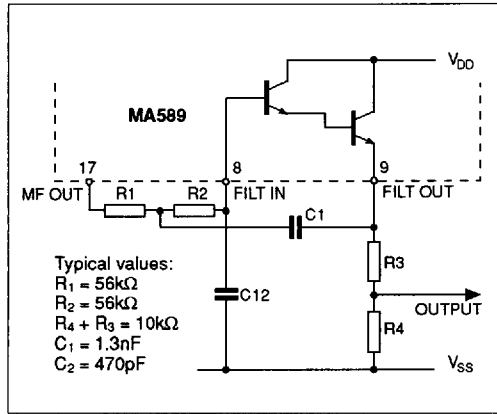

Figure 4: DTMF tone filtering

DTMF DIALLING

During DTMF dialling the MUTE output goes to logic '1' and remains there for the duration of the tone transmission.

The IMP output remains low during tone transmission. The MF OUT output rises to its DC level of 0.9 V_{DD} at the start of the tone transmission and is kept there between tone bursts. This is to avoid transients at the beginning and end of tone bursts.

The maximum rate at which tones are sent to line is 100ms on, followed by 100ms off. If keys are activated faster than this they are placed in a temporary store and then sent to line at the maximum rate. Dialling from the LNR store occurs at the maximum rate.

If a key is held down for longer than 100ms, the tone output will continue until the key is released.

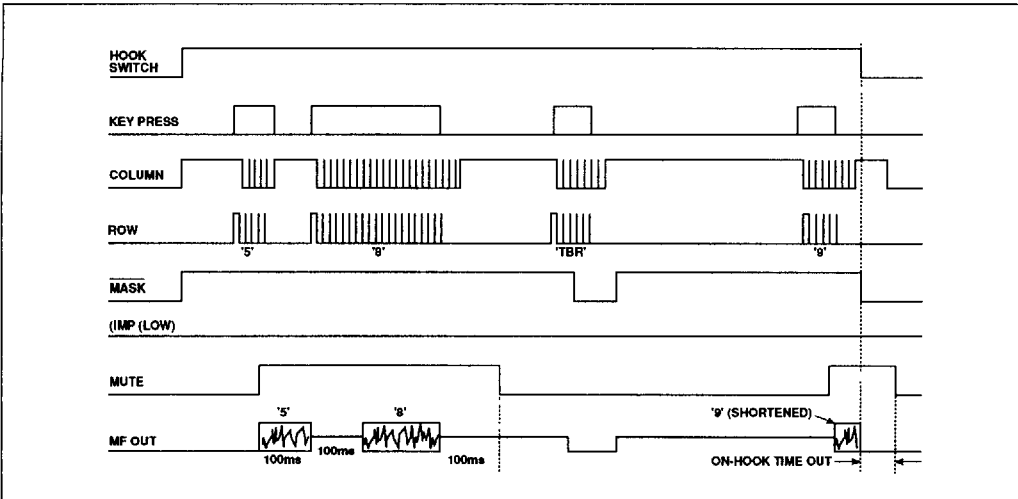

Figure 5: DTMF mode timing diagram

Keypad	R1	R2	R3	R4	C1	C2	C3	C4
Nominal frequency (Hz)	697	770	852	941	1209	1336	1477	1633
Deviation from nominal (%)	-0.07	-0.10	+0.19	-0.15	-0.17	-0.20	-0.22	-0.31

NOTE: There will be an additional frequency error caused by any deviation of the resonator frequency from the nominal 560kHz.

Table 3: Tone frequencies

LOOP-DISCONNECT DIALLING

The MASK output is provided in order to disable the speech circuit during LD dialling. Consequently, the MASK output is normally at logic '1' in the off-hook condition, but changes to logic '0' during LD dialling. MASK also changes to logic '0' in order to signal a Timed Break Recall (Flash) to the line.

Both MUTE and MF OUT remain low during LD dialling. LD dialling is signalled on the IMP output: a break is signalled by a logic '0', make periods and IDP times are signalled by a logic '1'. When not dialling, the IMP output sits at logic '0'.

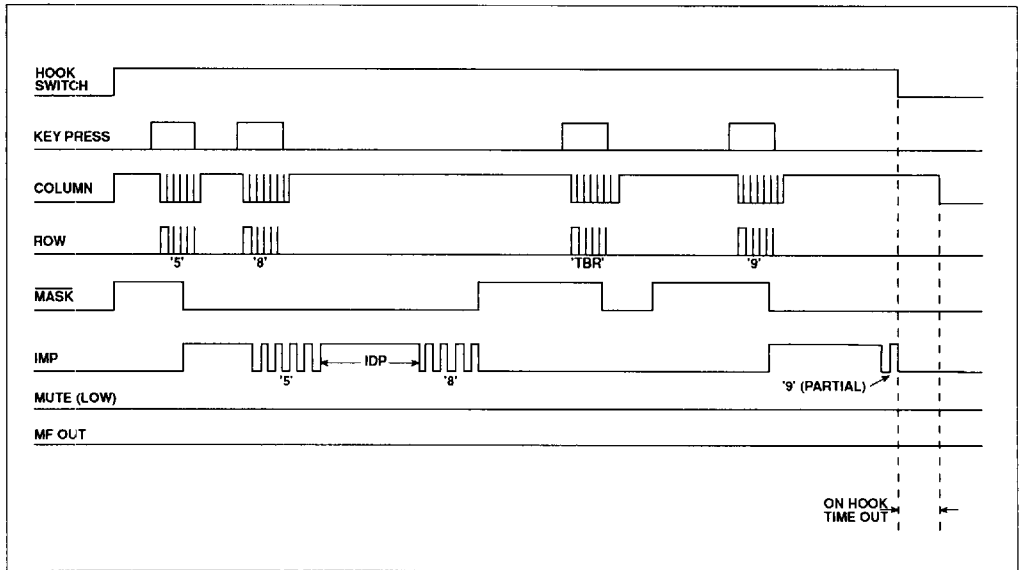

Figure 6: LD mode timing diagram

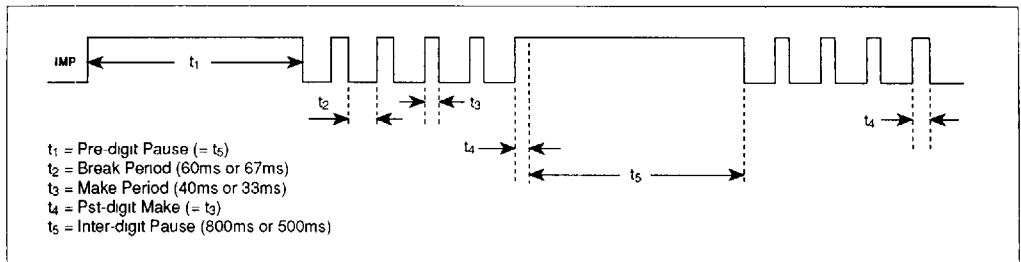

Figure 7 Timing data

MASK OPTIONS

The MA589 has been designed so that many features can be altered quickly and inexpensively at the final stage of manufacture. These options allow the telephone manufacturer to cater for different market requirements throughout the world without changing the telephone circuit. The options, listed below, are possible in any combination. Standard options are listed first in bold italics at 'a.' Other options may be produced by arrangement.

1. TBR (Flash) Period

- a. **100 ms**
- b. 200 ms
- c. 300 ms
- d. 400 ms
- e. 500 ms
- f. 600 ms

2. LD to DTMF Keypad Switching

- a. ***and # keys**
- b. TONE key
- c. * key

3. Retention of Post - */# Digits in LNR Store (DTMF mode)

- a. **All digits retained**
- b. Digits before * or # retained
- c. Digits before * and # retained (except when * or # is first digit)

4. LD dialling options

- a. **Standard (n = N pulses, except 0 = 10 pulses)**
- b. Swedish (n = (n + 1) pulses)
- c. Norwegian (n = (11 - n) pulses)
- d. New Zealand (n = (10 - n) pulses)

5. Recall (Flash) / LNR Protocol

- a. **Digits dialled after Recall retained**
- b. Digits dialled before Recall retained
- c. Recall inhibits LNR
- d. For Danish PABX requirements

6. DTMF Minimum Timings

- a. **100ms on, 100ms off**
- b. 73ms on, 73ms off
- c. 73ms on, 147ms off

7. Pin 5

- a. **MASK**
- b. MASK

8. Pin 3

- a. **IMP**
- b. IMP
- c. [IMP + MASK]
- d. [IMP + MASK]

9. Pin 18

- a. **MUTE**
- b. MUTE

APPLICATION CIRCUITS

Refer to the MA541 data sheet, Figs. 8 and 9, on pages 1-29 and 1-30

ELECTRICAL CHARACTERISTICS

Test conditions (unless otherwise stated): $V_{DD} = 2.5V$ $T_{amb} = 25^{\circ}C$

DC CHARACTERISTICS

Characteristic	Min.	Typ.	Max.	Units	Condition
Supply current:					$V_{DD} = 2.0V$. See note 1. MF OUT low
On-hook		<1	5.0	μA	
Off-hook		1.5		μA	
MFtone sending			1.0	mA	
LD impulsing			200	μA	
Output high voltage (MASK and MUTE and IMP outputs)	2.2			V	$I = -1mA$
Output low voltage (MASK and MUTE and IMP outputs)			0.3	V	$I = +1mA$
MF OUT DC level during tone sending		$0.9V_{DD}$		V	
MF OUT output resistance		3		k Ω	
'Key Pressed' resistance			2	k Ω	$2.5V < V_{DD} < 5.7V$
'Key Not Pressed' resistance	500			k Ω	$2.5V < V_{DD} < 5.7V$
Darlington pair current gain (see fig 4)	600	50,000			$I_E = 100\mu A, V_{CE} = 2V$

NOTE 1. Specially tested versions with guaranteed lower on-hook supply current are available.

AC CHARACTERISTICS

Characteristic	Min.	Typ.	Max.	Units	Condition
Tone output: low group high group	57	64 81	91	mV rms mV rms	No load No load
High-to-Low group amplitude ratio (pre emphasis)	1.5	2	2.5	dB	See note 2
Total harmonic distortion: 0-4 kHz 0-10 kHz 0-50 kHz 0-200 kHz		1.5 2.5 5.0 6.5	10	% % % %	
Oscillator start-up time		<0.1	1	ms	

NOTE 2. Typical value varies slightly dependent upon particular tone pair

RECOMMENDED OPERATING CONDITIONS

Condition	Min.	Typ.	Max.	Units	Notes
Supply Voltage. On-hook Off-hook	1.8 2.4		5.7 5.7	V V	For memory retention
Hookswitch input On-hook Off-hook	0.8V _{DD}		0.2V _{DD}	V V	
Oscillating frequency		560		kHz	

ABSOLUTE MAXIMUM RATINGS

Supply voltage, V _{DD} -V _{SS}	- 0.3 to + 6.5V
Voltage on any pin (except HSW)	V _{SS} - 0.3V to V _{DD} + 0.3V
Voltage on HSW pin (See note 1)	V _{SS} - 0.3V min.
Current at any I/O pin (except HSW, FILTOUT and FILTIN)	±1 mA
Current at FILTOUT pin	0 to 0.1 mA
Current at FILTIN pin	-5 to 0 mA
Storage temperature	-55°C to + 125°C
Operating temperature range	-10°C to + 55°C

NOTES

1 A diode is internally connected between this pin and V_{DD}. Provided current is externally limited to 300µA max. no damage will occur.

2 Stresses above those listed in the Absolute Maximum Ratings may cause permanent damage to the device. These are stress ratings only and functional operation of the device at these conditions, or at any other condition above those indicated in the Electrical Characteristics, is not implied. Exposure to Absolute Maximum Ratings conditions for extended periods may affect device reliability.