

# AN1393 (AN6914), AN1393S (AN6914S)

## Dual Comparators

### ■ Overview

The AN1393 (AN6914) and the AN1393S (AN6914S) are dual (voltage) comparators with wide range of operating supply voltage.

### ■ Features

- Wide range of operating voltages  
Single supply: 2 to 36V  
Dual supply:  $\pm 1$  to  $\pm 18$ V
- Low circuit current: 0.6mA typ.
- Wide range of common-mode input voltages  
: 0V to  $V_{CC}-1.5$ V (single supply)
- Open collector output

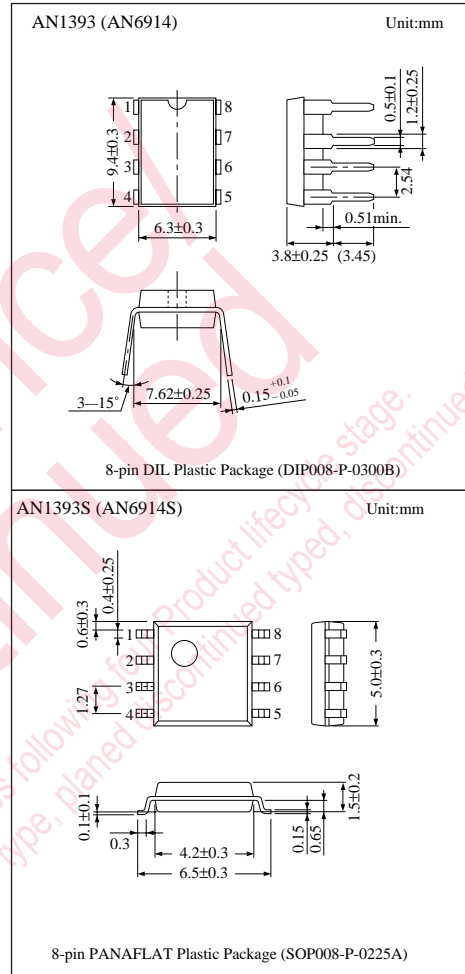

### ■ Block Diagram

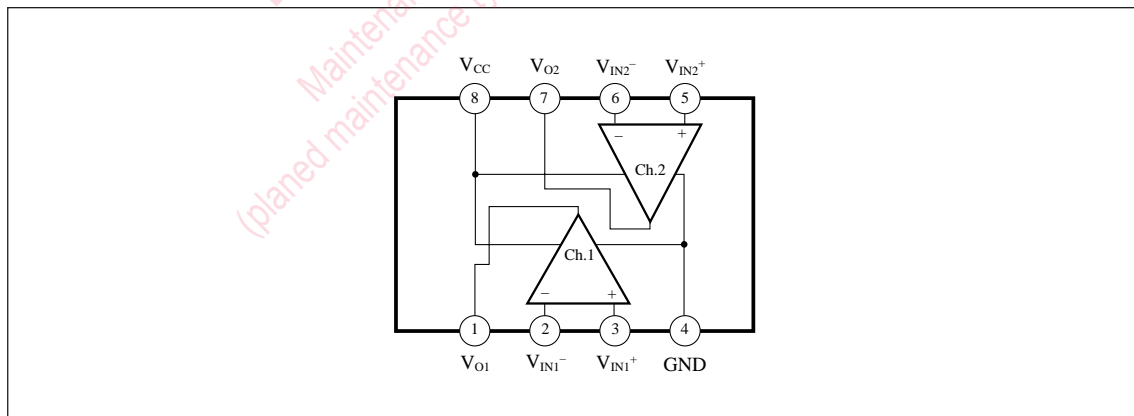

## Pin Descriptions

Pin No.	Pin name
1	Ch.1 output
2	Ch.1 inverting input
3	Ch.1 non inverting input
4	GND
5	Ch.2 non inverting input
6	Ch.2 inverting input
7	Ch.2 output
8	V <sub>CC</sub>

## Absolute Maximum Ratings (Ta=25°C)

Parameter		Symbol	Rating	Unit
Voltage	Supply voltage	V <sub>CC</sub>	36	V
	Common-mode input voltage	V <sub>ICM</sub> *1	- 0.3 to 36	V
	Differential input voltage	V <sub>ID</sub> *2	36	V
	Output applied voltage	V <sub>I</sub> , V <sub>7</sub>	24	V
Power dissipation	AN1393 (AN6914)	P <sub>D</sub>	500	mW
	AN1393S(AN6914S)		360	
Operating ambient temperature		T <sub>opr</sub>	- 30 to +85	°C
Storage temperature	AN1393(AN6914)	T <sub>stg</sub>	- 55 to +150	°C
	AN1393S(AN6914S)		- 55 to +125	

\*1 The common mode input voltage is a voltage applied to the non-inverting input pin and inverting input pin simultaneously.

\*2 Differential input is equivalent to the potential difference between the non-inverting input pin and inverting input pin.

## Recommended Operating Range (Ta=25°C)

Parameter	Symbol	Range
Operating supply voltage range	V <sub>CC</sub>	Single power supply 2V to 36V
		Double power supply ±1V to ±18V

## Electrical Characteristics (V<sub>CC</sub>=5V, Ta=25°C)

Parameter	Symbol	Condition	min	typ	max	Unit
Input offset voltage	V <sub>I(offset)</sub>		—	1	5	mV
Input offset current	I <sub>IO</sub>		—	—	50	nA
Input bias current	I <sub>Bias</sub>		—	—	250	nA
Voltage gain	G <sub>V</sub>	R <sub>L</sub> =15kΩ	—	200	—	V/mV
Common-mode input voltage range	V <sub>CM</sub>		0	—	V <sub>CC</sub> -1.5	V
Supply current	I <sub>CC</sub>	R <sub>L</sub> = ∞	—	0.6	1.5	mA
Response time	t <sub>r</sub>	R <sub>L</sub> =5.1kΩ, V <sub>RL</sub> =5V	—	1.3	—	μs
Output sink current	I <sub>SINK</sub>	V <sub>REF</sub> =0V, V <sub>IN</sub> =1V, V <sub>O</sub> ≤1.5V	10	—	—	mA
Low level output voltage	V <sub>OL</sub>	V <sub>REF</sub> =0V, V <sub>IN</sub> =1V, I <sub>SINK</sub> =3mA	—	0.2	0.4	V
Output terminal leakage current	I <sub>O(L,Leak)</sub>	V <sub>IN</sub> =0V, V <sub>REF</sub> =1V, V <sub>O</sub> =5V	—	0.1	—	nA

■ Characteristics Curve

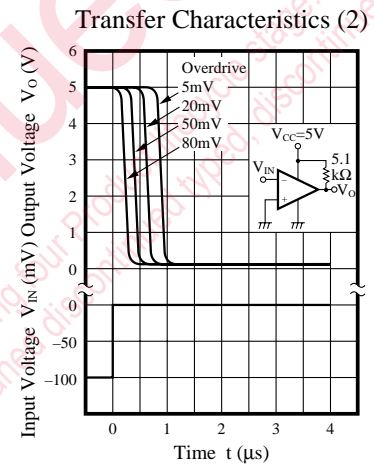
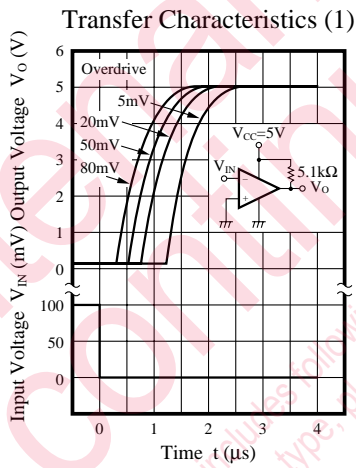
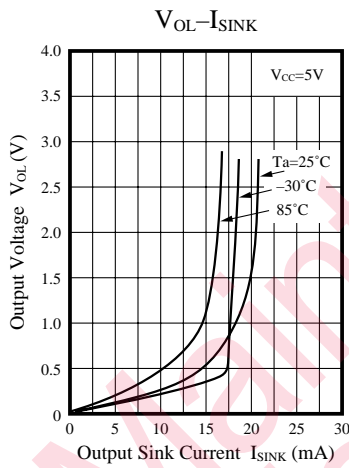
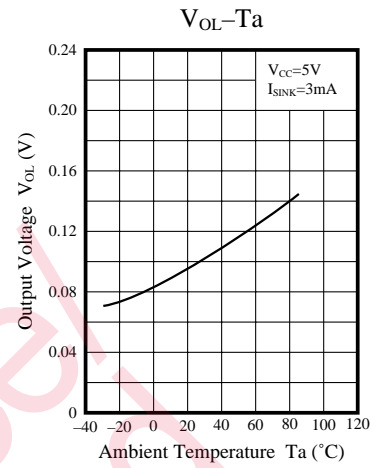
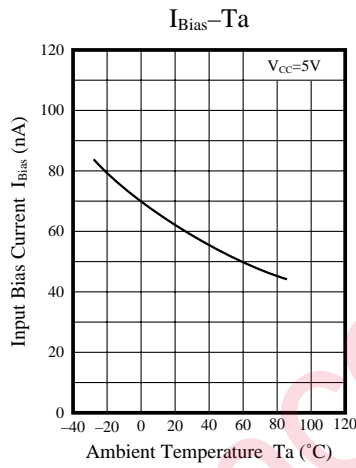
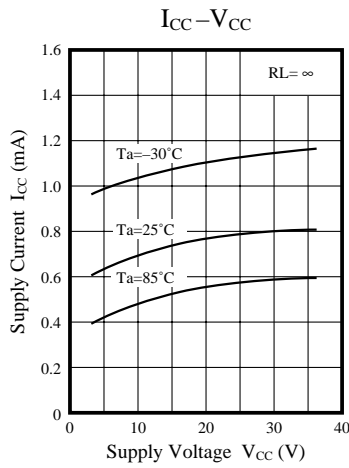

## Request for your special attention and precautions in using the technical information and semiconductors described in this book

- (1) If any of the products or technical information described in this book is to be exported or provided to non-residents, the laws and regulations of the exporting country, especially, those with regard to security export control, must be observed.
- (2) The technical information described in this book is intended only to show the main characteristics and application circuit examples of the products, and no license is granted under any intellectual property right or other right owned by our company or any other company. Therefore, no responsibility is assumed by our company as to the infringement upon any such right owned by any other company which may arise as a result of the use of technical information described in this book.
- (3) The products described in this book are intended to be used for standard applications or general electronic equipment (such as office equipment, communications equipment, measuring instruments and household appliances).  
Consult our sales staff in advance for information on the following applications:
  - Special applications (such as for airplanes, aerospace, automobiles, traffic control equipment, combustion equipment, life support systems and safety devices) in which exceptional quality and reliability are required, or if the failure or malfunction of the products may directly jeopardize life or harm the human body.
  - Any applications other than the standard applications intended.
- (4) The products and product specifications described in this book are subject to change without notice for modification and/or improvement. At the final stage of your design, purchasing, or use of the products, therefore, ask for the most up-to-date Product Standards in advance to make sure that the latest specifications satisfy your requirements.
- (5) When designing your equipment, comply with the range of absolute maximum rating and the guaranteed operating conditions (operating power supply voltage and operating environment etc.). Especially, please be careful not to exceed the range of absolute maximum rating on the transient state, such as power-on, power-off and mode-switching. Otherwise, we will not be liable for any defect which may arise later in your equipment.
  - Even when the products are used within the guaranteed values, take into the consideration of incidence of break down and failure mode, possible to occur to semiconductor products. Measures on the systems such as redundant design, arresting the spread of fire or preventing glitch are recommended in order to prevent physical injury, fire, social damages, for example, by using the products.
- (6) Comply with the instructions for use in order to prevent breakdown and characteristics change due to external factors (ESD, EOS, thermal stress and mechanical stress) at the time of handling, mounting or at customer's process. When using products for which damp-proof packing is required, satisfy the conditions, such as shelf life and the elapsed time since first opening the packages.
- (7) This book may be not reprinted or reproduced whether wholly or partially, without the prior written permission of Matsushita Electric Industrial Co., Ltd.