

Philips Components

| | |
|---------------|-----------------------|
| Document No. | 853-0655 |
| ECN No. | 99799 |
| Date of Issue | June 14, 1990 |
| Status | Product Specification |
| ECL Products | |

10121 Gate

4-Wide OR-AND/OR-AND-INVERT Gate

FEATURES

- Typical propagation delay: 2.3ns
- Typical supply current ($-I_{EE}$): 20mA

DESCRIPTION

The 10121 is a 4-Wide OR-AND/OR-AND-INVERT Gate designed for use in data control as a general purpose logic element. All unused inputs can be left open due to integrated pull-down resistors, which avoid the need for a supply voltage.

ORDERING INFORMATION

| DESCRIPTION | ORDER CODE |
|--------------------|------------|
| 16-Pin Plastic DIP | 10121N |
| 16-Pin Ceramic DIP | 10121F |

PIN DESCRIPTION

| PINS | DESCRIPTION |
|------------------|--------------|
| $D_0 - D_{10}$ | Data Inputs |
| \bar{Q}_0, Q_1 | Data Outputs |

PIN CONFIGURATION

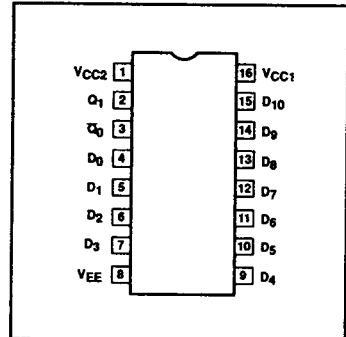

LOGIC DIAGRAM

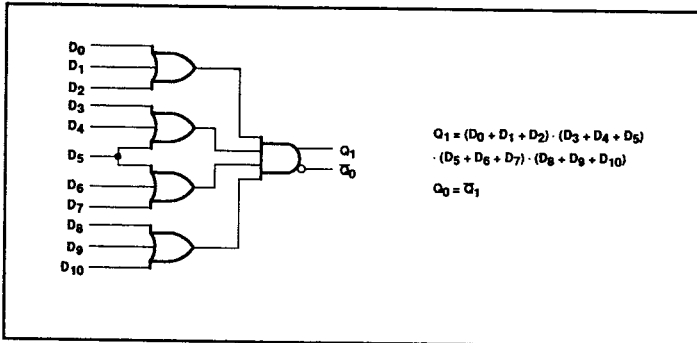

Gate

10121

SIMPLIFIED SCHEMATIC

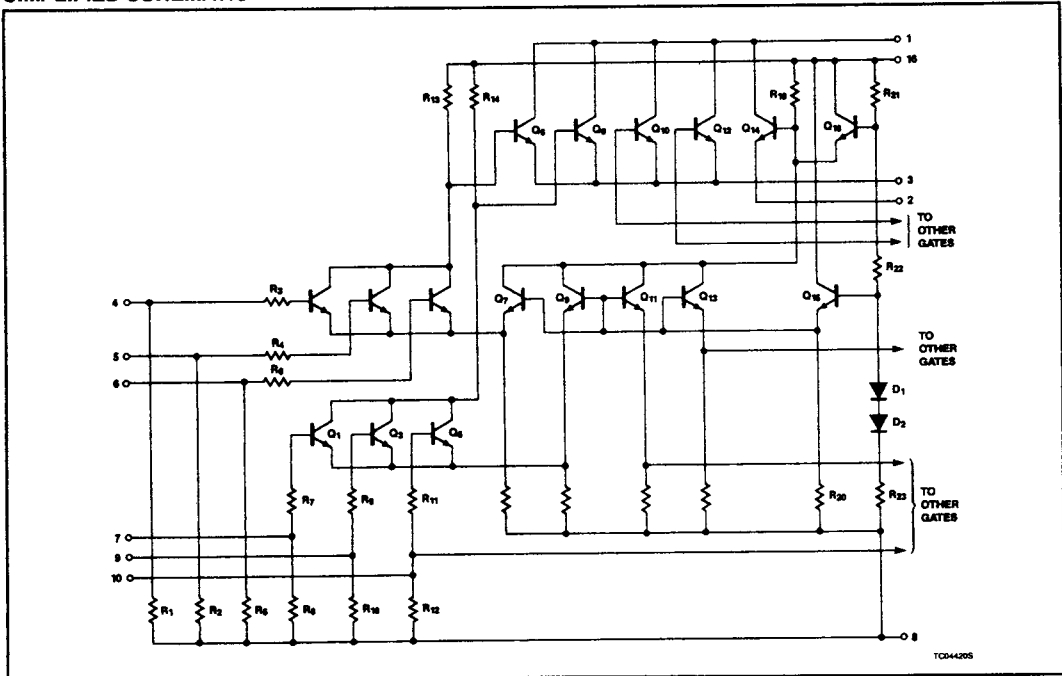

ABSOLUTE MAXIMUM RATINGS

| SYMBOL | PARAMETER | LIMITS | UNIT | |
|----------|--|-----------------|------|----|
| V_{EE} | Supply voltage | -8.0 | V | |
| V_{IN} | Input voltage (V_{IN} should never be more negative than V_{EE}) | 0 to V_{EE} | V | |
| I_O | Output source current (continuous) | -50 | mA | |
| T_S | Storage temperature range | -55 to +150 | °C | |
| T_J | Maximum junction temperature | Ceramic Package | +165 | °C |
| | | Plastic Package | +150 | °C |

NOTE:

Operation beyond the limits set forth in this table may impair the useful life of the device. Unless otherwise noted, these limits are specified over the operating ambient temperature range.

Gate

10121

DC OPERATING CONDITIONS

| SYMBOL | PARAMETER | TEST CONDITIONS | LIMITS | | | UNIT |
|--------------------|-------------------------------------|---------------------------|--------|------|-------|------------------|
| | | | MIN. | NOM. | MAX. | |
| V_{CC1}, V_{CC2} | Circuit ground | | 0 | 0 | 0 | V |
| V_{EE} | Supply voltage (negative) | | | -5.2 | | V |
| V_{IH} | High level input voltage | $T_A = -30^\circ\text{C}$ | | | -890 | mV |
| | | $T_A = +25^\circ\text{C}$ | | | -810 | mV |
| | | $T_A = +85^\circ\text{C}$ | | | -700 | mV |
| V_{IHT} | High level input threshold voltage | $T_A = -30^\circ\text{C}$ | -1205 | | | mV |
| | | $T_A = +25^\circ\text{C}$ | -1105 | | | mV |
| | | $T_A = +85^\circ\text{C}$ | -1035 | | | mV |
| V_{ILT} | Low level input threshold voltage | $T_A = -30^\circ\text{C}$ | | | -1500 | mV |
| | | $T_A = +25^\circ\text{C}$ | | | -1475 | mV |
| | | $T_A = +85^\circ\text{C}$ | | | -1440 | mV |
| V_{IL} | Low level input voltage | $T_A = -30^\circ\text{C}$ | -1890 | | | mV |
| | | $T_A = +25^\circ\text{C}$ | -1850 | | | mV |
| | | $T_A = +85^\circ\text{C}$ | -1825 | | | mV |
| T_A | Operating ambient temperature range | | -30 | +25 | +85 | $^\circ\text{C}$ |

NOTE:

When operating at other than the specified V_{EE} voltage (-5.2V), the DC and AC Electrical Characteristics will vary slightly from specified values.

Gate

10121

DC ELECTRICAL CHARACTERISTICS $V_{CC1} = V_{CC2} = \text{ground}, V_{EE} = -5.2V \pm 0.010V, T_A = -30^\circ\text{C}$ to $+85^\circ\text{C}$ output loading 50Ω to $-2.0V \pm 0.010V$ unless otherwise specified^{1,3}

| SYMBOL | PARAMETER | | TEST CONDITIONS ² | | LIMITS | | | UNIT |
|---------------------------------------|--|----------------------|------------------------------|---|--------|-------|-------|------|
| | | | | | MIN. | TYP. | MAX. | |
| V _{OH} | High level output voltage | | T _A = -30°C | For Q ₁ output, apply V _{IHM} AX to all inputs. For Q ₀ output apply V _{ILMIN} to all inputs. | -1060 | | -780 | mV |
| | | | T _A = +25°C | | -960 | | -700 | mV |
| | | | T _A = +85°C | | -890 | | -590 | mV |
| V _{OHT} | High level output threshold voltage | | T _A = -30°C | For Q ₁ output apply V _{IHT} to D ₀ input with V _{ILMIN} applied to D ₁ and D ₂ inputs and V _{IHM} AX applied to all other inputs. For Q ₀ output, apply V _{ILT} to D ₀ input with V _{ILMIN} applied to D ₁ and D ₂ and V _{IHM} AX applied to all other inputs. | -1080 | | | mV |
| | | | T _A = +25°C | | -980 | | | mV |
| | | | T _A = +85°C | | -910 | | | mV |
| V _{OLT} | Low level output threshold voltage | | T _A = -30°C | For Q ₁ output apply V _{ILT} to D ₀ input with V _{ILMIN} applied to D ₁ and D ₂ inputs and V _{IHM} AX applied to all other inputs. For Q ₀ output, apply V _{IHT} to D ₀ input with V _{ILMIN} applied to D ₁ and D ₂ and V _{IHM} AX applied to all other inputs. | | | -1655 | mV |
| | | | T _A = +25°C | | | | -1630 | mV |
| | | | T _A = +85°C | | | | -1595 | mV |
| V _{OL} | Low level output voltage | | T _A = -30°C | For Q ₁ output, apply V _{ILMIN} to all inputs. For Q ₀ output apply V _{IHM} AX to all inputs. | -2000 | | -1675 | mV |
| | | | T _A = +25°C | | -1990 | | -1650 | mV |
| | | | T _A = +85°C | | -1920 | | -1615 | mV |
| I _{IH} | High level input current | D ₅ input | T _A = -30°C | Apply V _{IHM} AX to each input under test, one at a time, with V _{ILMIN} applied to all other inputs. | | | 495 | μA |
| | | | T _A = +25°C | | | | 310 | μA |
| | | | T _A = +85°C | | | | 310 | μA |
| | | All other inputs | T _A = -30°C | | | | 390 | μA |
| | | | T _A = +25°C | | | | 245 | μA |
| | | | T _A = +85°C | | | | 245 | μA |
| I _{IL} | Low level input current | | T _A = -30°C | Apply V _{ILMIN} to each input under test, one at a time, with V _{IHM} AX applied to all other inputs. | 0.5 | | | μA |
| | | | T _A = +25°C | | 0.5 | | | μA |
| | | | T _A = +85°C | | 0.3 | | | μA |
| -I _{EE} | V _{EE} supply current | | T _A = -30°C | | | | 29 | mA |
| | | | T _A = +25°C | | | 20 | 26 | mA |
| | | | T _A = +85°C | | | | 29 | mA |
| $\frac{\Delta V_{OH}}{\Delta V_{EE}}$ | High level output voltage compensation | | T _A = +25°C | | | 0.016 | | V/V |
| $\frac{\Delta V_{OL}}{\Delta V_{EE}}$ | Low level output voltage compensation | | | | | 0.250 | | V/V |
| $\frac{\Delta V_{BB}}{\Delta V_{EE}}$ | Reference bias voltage compensation | | | | | 0.148 | | V/V |

NOTES:

1. The specified limits represent the worst case values for the parameter. Since these worst case values normally occur at the supply voltage and temperature extremes, additional noise immunity can be achieved by decreasing the allowable operating condition ranges.
2. Conditions for testing shown in the tables are not necessarily worst case. For worst case testing guidelines, refer to DC Testing, Chapter 1, Section 3.
3. The specified limits shown in the DC Electrical Characteristics table can be met only after thermal equilibrium has been established. Thermal equilibrium is established by applying power for at least 2 minutes, while maintaining transverse airflow of 2.5 meters/sec (500 linear feet/min) over the device, mounted either in a test socket or on a printed circuit board. Test voltage values are given in the DC Operating Conditions table.

Gate

10121

AC ELECTRICAL CHARACTERISTICS $V_{CC1} = V_{CC2} = \text{ground}, V_{EE} = -5.2V \pm 0.010V$

| SYMBOL | PARAMETER | TEST CONDITION | LIMITS | | | | | | | UNIT |
|------------------------|--|-------------------|---------------------------|------|---------------------------|------|------|---------------------------|------|------|
| | | | $T_A = -30^\circ\text{C}$ | | $T_A = +25^\circ\text{C}$ | | | $T_A = +85^\circ\text{C}$ | | |
| | | | MIN. | MAX. | MIN. | TYP. | MAX. | MIN. | MAX. | |
| t_{PLH} t_{PHL} | Propagation delay D_n to \bar{Q}_0, Q_1 | Waveform 1 | 1.40 | 3.90 | 1.40 | 2.30 | 3.40 | 1.40 | 3.80 | ns |
| | | | 1.40 | 3.90 | 1.40 | 2.30 | 3.40 | 1.40 | 3.80 | ns |
| t_{TLH} t_{THL} | Transition time 20% to 80%, 80% to 20% | | 0.90 | 4.10 | 1.10 | 2.50 | 4.00 | 1.10 | 4.60 | ns |
| | | | 0.90 | 4.10 | 1.10 | 2.50 | 4.00 | 1.10 | 4.60 | ns |

NOTE:

For AC test setup information, see AC Testing, Chapter 2, Section 3.