

THIS PRODUCT MANUFACTURED WITH LEAD-FREE PROCESSING

DESIGNED & DIMENSIONED IN MILLIMETERS [INCHES]

DO NOT SCALE FROM THIS PRINT

SSMB-P-C-XX-ST-CA1

GENDER
-P: PLUG

TYPE
-C: CABLE

TERMINATION
-CA1: RG316U/RG174U CABLE

ORIENTATION
-ST: STRAIGHT

PLATING SPECIFICATION
-HG: 30µ" GOLD CENTER CONTACT, 10µ" GOLD OUTER CONTACT
-GF: 10µ" GOLD CENTER CONTACT, 3µ" GOLD OUTER CONTACT (SEE TABLE 1)

B

TABLE 1			
ITEM	COMPONENT	-HG	-GF
1	SUB ASSEMBLY	SUB-SSMB-P-C-GN-ST-CA1	SUB-SSMB-P-C-FN-ST-CA1
2	SOCKET	SSMB-P-C-H-ST-CA1-SKT	SSMB-P-C-G-ST-CA1-SKT
3	OUTER FERRULE	SMA-FER-001-N	

B

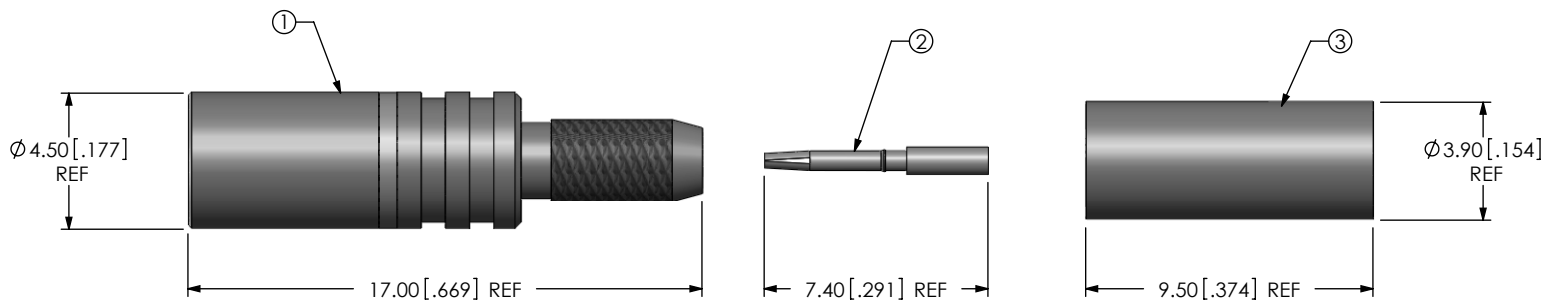

B

B

NOTES:

1. Ⓢ REPRESENTS A CRITICAL DIMENSION.
2. NOTE DELETED.
3. PRODUCT TO BE PACKAGED PER PACKAGING STANDARD CO-HD-WI-3040-M. TRAY: TY-SMA001-1 COVER: TY-SMA001-2 200 PARTS PER TRAY (2 PARTS PER POCKET).
4. SOCKET AND FERRULE TO BE PACKAGED SEPARATELY.
5. NOTE DELETED.
6. NOTE DELETED.
7. NOTE DELETED.
8. NOTE DELETED.

UNLESS OTHERWISE SPECIFIED, DIMENSIONS ARE IN MILLIMETERS [INCHES]. TOLERANCES ARE: DECIMALS ANGLES .X: $\pm 0.3 [.01]$ 5° .XX: $\pm 0.13 [.005]$.XXX: $\pm 0.051 [.0020]$	PROPRIETARY NOTE THIS DOCUMENT CONTAINS INFORMATION CONFIDENTIAL AND PROPRIETARY TO SAMTEC, INC. AND SHALL NOT BE REPRODUCED OR TRANSFERRED TO OTHER DOCUMENTS OR DISCLOSED TO OTHERS OR USED FOR ANY PURPOSE OTHER THAN THAT WHICH IT WAS OBTAINED WITHOUT THE EXPRESSED WRITTEN CONSENT OF SAMTEC, INC.	 520 PARK EAST BLVD, NEW ALBANY, IN 47150 PHONE: 812-944-6733 FAX: 812-948-5047 e-Mail: info@SAMTEC.com code: 55322
BY: DUKES Z 11/08/2010		SHEET 1 OF 2

REVISION B

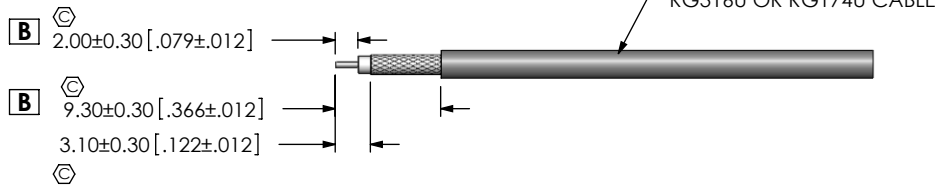

IN-PROCESS 1
STRIP AND TIN INNER
CONDUCTOR



IN-PROCESS 2
SOLDER SIGNAL SOCKET

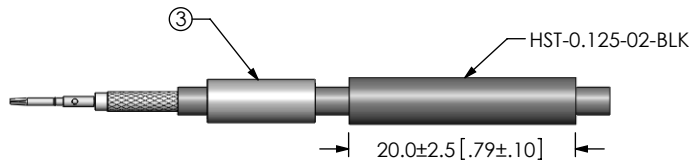

IN-PROCESS 3
ADD HEAT SHRINK
TUBE AND FERRULE

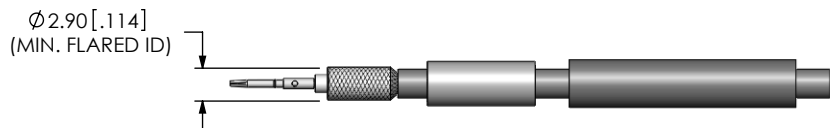

IN-PROCESS 4
FLARE SHIELD

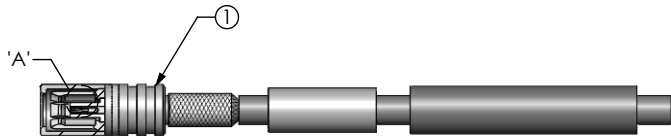

IN-PROCESS 5
ADD SUB ASSEMBLY

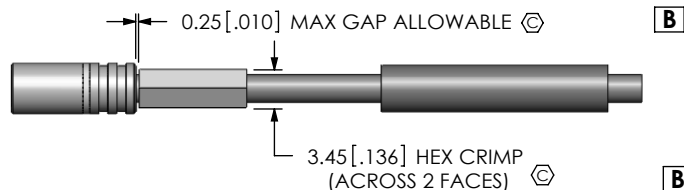

IN-PROCESS 6
CRIMP FERRULE
(USE RF CRIMP HAND
TOOL # CAT-HT-126667-21
OR EQUIVALENT)
(USE .136" HEX DIE)



IN-PROCESS 7
APPLY HEAT
SHRINK TUBING

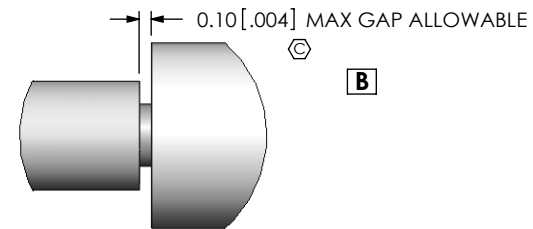

DETAIL 'B'
SCALE 16:1

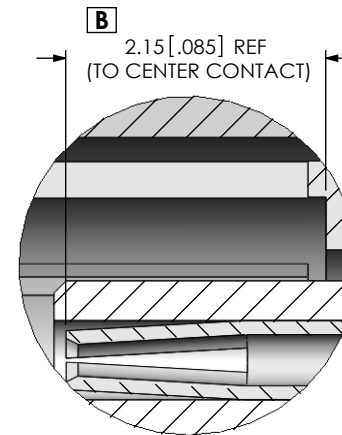

DETAIL 'A'
SCALE 16:1

B

PROPRIETARY NOTE

THIS DOCUMENT CONTAINS INFORMATION CONFIDENTIAL AND PROPRIETARY TO SAMTEC, INC. AND SHALL NOT BE REPRODUCED OR TRANSFERRED TO OTHER DOCUMENTS OR DISCLOSED TO OTHERS OR USED FOR ANY PURPOSE OTHER THAN THAT WHICH IT WAS OBTAINED WITHOUT THE EXPRESSED WRITTEN CONSENT OF SAMTEC, INC.

DO NOT SCALE DRAWING

SHEET SCALE: 3:2



520 PARK EAST BLVD, NEW ALBANY, IN 47150
PHONE: 812-944-6733 FAX: 812-948-5047
e-Mail: info@SAMTEC.com code: 55322

DESCRIPTION:
SSMB ST, CABLE, PLUG, RG316U/RG174U 50 OHM

DWG. NO.
SSMB-P-C-XX-ST-CA1

BY: DUKES Z 11/08/2010 SHEET 2 OF 2