

Dot Matrix LED Unit for Outdoor Use LT1465ED(Lamp Type)

■ Features

- No. of dots : 16X16dots
- Outline dimensions : 64X64mm
- Dot size : ø3.0mm
- Dot pitch : 4.0mm
- Radiation color : Yellow-green+Red (dichromatic type)
- Driving method : 1/16 duty dynamic drive

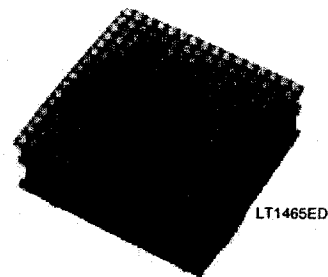

■ Absolute Maximum Ratings

(Ta=25°C)

Supply voltage for IC	VCC	5.5	V
Supply voltage for LED	VLED	5.5	V
Input voltage*1	VI	5.5	V
Turn-on time	ton	1	ms
Operating temperature	Topr	-20 to +45	°C
Storage temperature	Tstg	-25 to +85	°C
Power dissipation	P	13	W

*1 VI<Vcc at Vcc≤5

■ Optical Characteristics

(VCC=5V,VLED=5V,Ta=25°C)

Viewing angle	2θ1/2	110	°
Peak emission wavelength	Red	635	nm
	Yellow-green	565	

■ Luminance

Luminance is classified into 2 ranks shown below. It is adjustable by variable registers. (VCC=5V,VLED=5V,Ta=25°C)

Red	160	200	cd/m ²
Yellow-green	160	200	

■ Terminal Functions

Power supply (CN1)	VLED	Supply voltage for LED (+5V)
	VCC	Supply voltage for IC (+5V)
	GND1	Ground for IC
	GND2	Ground for LED
Input signal (CN2)	A0 to A3	Address specification signal for row driver
	RDATA	Serial data input for red (H=ON, L=OFF) Shift from right to left(VD15→VD0) in the unit
	GDATA	Serial data input for yellow-green (H=ON, L=OFF) Shift from right to left(VD15→VD0) in the unit
	LATCH	Latch signal of display data.L→H: Contents of shift register are latched.
	ENABLE	Controls ON/OFF of LED (H: LED OFF)
	CLOCK	Clock signal for data transmission in the shift-register. (L→H: Serial data is shifted.)
	GND1	Ground for signal. (Connected to ground for IC)
Output signal (CN3)	A0 to A3	Buffered input signal
	RDATA	Input signal generated through 16-bit shift register or buffer
	GDATA	Input signal generated through 16-bit shift register or buffer
	LATCH	Buffered input signal
	ENABLE	Buffered input signal
	CLOCK	Buffered input signal
	GND1	Ground for signal. (Connected to ground for IC)

Each signal is used as input signal for next unit.

* As for the terminal number, refer to the outline dimensions.

■ Electrical Characteristics

(VCC=5V,VLED=5V,Ta=25°C)

Supply voltage for IC	VCC	4.75	5.0	5.25	V
Supply voltage for LED	VLED	4.75	5.0	5.25	V
IC current dissipation*1	ICC	—	20	40	mA
LED current dissipation*1	ILED	—	1.7	2.0	A
Input voltage	VIH	3.5	—	—	V
	VIL	—	—	1.5	V
Input current	IIH	—	—	0.1	μA
	IIL	—	—	0.12	mA
Clock frequency	fCLK	—	—	3.0	MHz
Frame frequency	fFR	80	100	—	Hz

*1 Under the condition that dichromatic all dots are lit.

■ Timing Chart

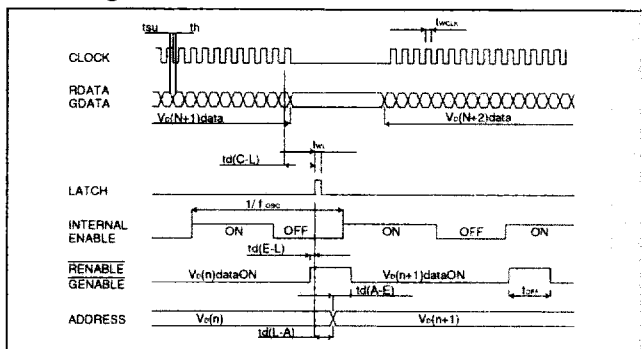

■ Block Diagram

