

## F100115 Low-Skew Quad Clock Driver

### General Description

The F100115 contains four low skew differential drivers, designed for generation of multiple, minimum skew differential clocks from a single differential input. This device also has the capability to select a secondary single-ended clock source for use in lower frequency system level testing.

### Features

- Low output to output skew ( $\leq 75$  ps)
- Differential inputs and outputs
- Small outline package
- Ideal for applications which require the low skew distribution of a clock signal to multiple outputs
- Secondary clock available for system level testing

**Ordering Code:** See Section 8

### Logic Diagram

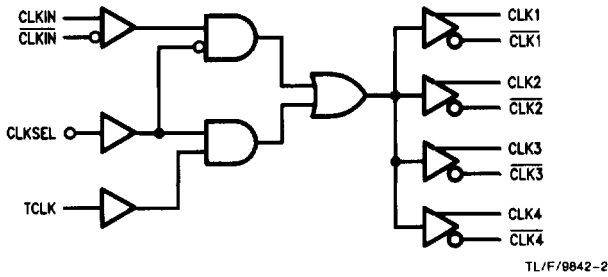

### Connection Diagram

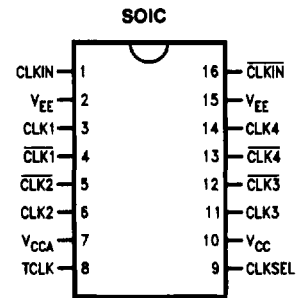

| Pin Names  | Description                |
|--|----------------------------|
| CLKIN, $\overline{\text{CLKIN}}$                   | Differential Clock Inputs  |
| CLK <sub>1-4</sub> , $\overline{\text{CLK}}_{1-4}$ | Differential Clock Outputs |
| TCLK   | Test Clock Input†          |
| CLKSEL   | Clock Input Select†        |

†TCLK and CLKSEL are single-ended inputs, with internal 50 k $\Omega$  pulldown resistors.

### Truth Table

| CLKSEL | CLKIN | $\overline{\text{CLKIN}}$ | TCLK | CLK <sub>N</sub> | $\overline{\text{CLK}}_{N}$ |
|--------|-------|---------------------------|------|------------------|-----------------------------|
| L      | L     | H                         | X    | L                | H                           |
| L      | H     | L                         | X    | H                | L                           |
| H      | X     | X                         | L    | L                | H                           |
| H      | X     | X                         | H    | H                | L                           |

L = Low Voltage Level

H = High Voltage Level

X = Don't Care

## Absolute Maximum Ratings

Above which the useful life may be impaired (Note 1)

If Military/Aerospace specified devices are required, please contact the National Semiconductor Sales Office/Distributors for availability and specifications.

Storage Temperature -65°C to +150°C

Maximum Junction Temperature (T<sub>J</sub>) +150°C

Case Temperature under Bias (T<sub>C</sub>)

0°C to +85°C

V<sub>EE</sub> Pin Potential to Ground Pin

-7.0V to +0.5V

Input Voltage (DC)

V<sub>CC</sub> to +0.5V

Output Current (DC Output HIGH)

-50 mA

Operating Range (Note 2)

-5.7V to -4.2V

## DC Electrical Characteristics

V<sub>EE</sub> = -4.5V, V<sub>CC</sub> = V<sub>CCA</sub> = GND, T<sub>C</sub> = 0°C to +85°C (Note 3)

| Symbol           | Parameter                          | Min   | Typ   | Max   | Units | Conditions (Note 4)   |                              |
|------------------|------------------------------------|-------|-------|-------|-------|---|------------------------------|
| V <sub>OH</sub>  | Output HIGH Voltage                | -1025 | 955   | -880  | mV    | V <sub>IN</sub> = V <sub>IH</sub> (Max)<br>or V <sub>IL</sub> (Min) | Loading with<br>50Ω to -2.0V |
| V <sub>OL</sub>  | Output LOW Voltage                 | -1810 | -1705 | -1620 |       |   |                              |
| V <sub>OHc</sub> | Output HIGH Voltage                | -1035 |       |       | mV    | V <sub>IN</sub> = V <sub>IH</sub> (Min)<br>or V <sub>IL</sub> (Max) | Loading with<br>50Ω to -2.0V |
| V <sub>OLc</sub> | Output LOW Voltage                 |       |       | -1610 |       |   |                              |
| V <sub>IH</sub>  | Single-Ended<br>Input HIGH Voltage | 1165  |       | 880   | mV    | Guaranteed HIGH Signal<br>for All Inputs                            |                              |
| V <sub>IL</sub>  | Single-Ended<br>Input LOW Voltage  | 1810  |       | 1475  | mV    | Guaranteed LOW Signal<br>for All Inputs                             |                              |
| I <sub>IL</sub>  | Input LOW Current                  | 0.50  |       |       | μA    | V <sub>IN</sub> = V <sub>IL</sub> (Min)                             |                              |

## DC Electrical Characteristics

V<sub>EE</sub> = -4.2V, V<sub>CC</sub> = V<sub>CCA</sub> = GND, T<sub>C</sub> = 0°C to +85°C (Note 3)

| Symbol           | Parameter                          | Min   | Typ | Max   | Units | Conditions (Note 4)   |                              |
|------------------|------------------------------------|-------|-----|-------|-------|---|------------------------------|
| V <sub>OH</sub>  | Output HIGH Voltage                | -1020 |     | -870  | mV    | V <sub>IN</sub> = V <sub>IH</sub> (Max)<br>or V <sub>IL</sub> (Min) | Loading with<br>50Ω to -2.0V |
| V <sub>OL</sub>  | Output LOW Voltage                 | 1810  |     | -1605 |       |   |                              |
| V <sub>OHc</sub> | Output HIGH Voltage                | -1030 |     |       | mV    | V <sub>IN</sub> = V <sub>IH</sub> (Min)<br>or V <sub>IL</sub> (Max) | Loading with<br>50Ω to -2.0V |
| V <sub>OLc</sub> | Output LOW Voltage                 |       |     | -1595 |       |   |                              |
| V <sub>IH</sub>  | Single-Ended<br>Input HIGH Voltage | -1150 |     | 870   | mV    | Guaranteed HIGH Signal<br>for All Inputs                            |                              |
| V <sub>IL</sub>  | Single-Ended<br>Input LOW Voltage  | -1810 |     | -1475 | mV    | Guaranteed LOW Signal<br>for All Inputs                             |                              |
| I <sub>IL</sub>  | Input LOW Current                  | 0.50  |     |       | μA    | V <sub>IN</sub> = V <sub>IL</sub> (Min)                             |                              |

## DC Electrical Characteristics

V<sub>EE</sub> = -4.8V, V<sub>CC</sub> = V<sub>CCA</sub> = GND, T<sub>C</sub> = 0°C to +85°C (Note 3)

| Symbol           | Parameter                          | Min  | Typ | Max   | Units | Conditions (Note 4)   |                              |
|------------------|------------------------------------|------|-----|-------|-------|---|------------------------------|
| V <sub>OH</sub>  | Output HIGH Voltage                | 1035 |     | -880  | mV    | V <sub>IN</sub> = V <sub>IH</sub> (Max)<br>or V <sub>IL</sub> (Min) | Loading with<br>50Ω to -2.0V |
| V <sub>OL</sub>  | Output LOW Voltage                 | 1830 |     | 1620  |       |   |                              |
| V <sub>OHc</sub> | Output HIGH Voltage                | 1045 |     |       | mV    | V <sub>IN</sub> = V <sub>IH</sub> (Min)<br>or V <sub>IL</sub> (Max) | Loading with<br>50Ω to -2.0V |
| V <sub>OLc</sub> | Output LOW Voltage                 |      |     | -1610 |       |   |                              |
| V <sub>IH</sub>  | Single-Ended<br>Input HIGH Voltage | 1165 |     | 880   | mV    | Guaranteed HIGH Signal<br>for All Inputs                            |                              |
| V <sub>IL</sub>  | Single-Ended<br>Input LOW Voltage  | 1830 |     | -1490 | mV    | Guaranteed LOW Signal<br>for All Inputs                             |                              |
| I <sub>IL</sub>  | Input LOW Current                  | 0.50 |     |       | μA    | V <sub>IN</sub> = V <sub>IL</sub> (Min)                             |                              |

**Note 1:** Absolute maximum ratings are those values beyond which the device may be damaged or have its useful life impaired. Functional operation under these conditions is not implied.

**Note 2:** Parametric values specified at -4.2V to -4.8V.

**Note 3:** The specified limits represent the "worst case" value for the parameter. Since these "worst case" values normally occur at the temperature extremes, additional noise immunity and guard banding can be achieved by decreasing the allowable system operating ranges.

**Note 4:** Conditions for testing shown in the tables are chosen to guarantee operation under "worst case" conditions.

### DC Electrical Characteristics

$V_{EE} = -4.2V$  to  $-4.8V$  unless otherwise specified,  $V_{CC} = V_{CCA} = GND$ ,  $T_C = 0^\circ C$  to  $+85^\circ C$

| Symbol     | Parameter   | Min           | Typ | Max               | Units                         | Conditions                     |
|------------|---|---------------|-----|-------------------|-------------------------------|--------------------------------|
| $V_{DIFF}$ | Input Voltage Differential  | 150           |     |                   | mV                            | Required for Full Output Swing |
| $V_{CM}$   | Common Mode Voltage   | $V_{CC} - 2V$ |     | $V_{CC} - 0.5V$   | V                             |                                |
| $I_{IH}$   | Input High Current<br>CLKIN, $\overline{CLKIN}$<br>TCLK<br>CLKSEL |               |     | 107<br>300<br>260 | $\mu A$<br>$\mu A$<br>$\mu A$ | $V_{IN} = V_{IH(Max)}$         |
| $I_{CBO}$  | Input Leakage Current   | -10           |     |                   | $\mu A$                       | $V_{IN} = V_{EE}$              |
| $I_{EE}$   | Power Supply Current  | -70           |     | -30               | mA                            |                                |

### AC Electrical Characteristics

$V_{EE} = -4.2V$  to  $-4.8V$ ,  $V_{CC} = V_{CCA} = GND$

| Symbol                 | Parameter   | $T_C = 0^\circ C$ |      | $T_C = +25^\circ C$ |      | $T_C = +85^\circ C$ |      | Units | Conditions   |
|------------------------|---|-------------------|------|---------------------|------|---------------------|------|-------|--------------|
|                        |   | Min               | Max  | Min                 | Max  | Min                 | Max  |       |              |
| $t_{PLH}$<br>$t_{PHL}$ | Propagation Delay CLKIN,<br>CLKIN to $CLK_{(1-4)}$ , $\overline{CLK}_{(1-4)}$ | 0.63              | 0.83 | 0.65                | 0.85 | 0.70                | 0.93 | ns    | Figures 1, 3 |
| $t_{PLH}$<br>$t_{PHL}$ | Propagation Delay, TCLK<br>to $CLK_{(1-4)}$ , $\overline{CLK}_{(1-4)}$        | 0.50              | 1.20 | 0.50                | 1.20 | 0.50                | 1.20 | ns    | Figures 1, 2 |
| $t_{PLH}$<br>$t_{PHL}$ | Propagation Delay, CLKSEL<br>to $CLK_{(1-4)}$ , $\overline{CLK}_{(1-4)}$      | 0.60              | 1.40 | 0.60                | 1.40 | 0.60                | 1.40 | ns    | Figures 1, 2 |
| $t_{S\ G-G}$           | Skew Gate to Gate (Note 1)  |                   | 75   |                     | 75   |                     | 75   | ps    |              |
| $t_{TLH}$<br>$t_{THL}$ | Transition Time<br>20% to 80%, 80% to 20%                                     | 0.35              | 0.80 | 0.30                | 0.75 | 0.25                | 0.75 | ns    | Figures 1, 4 |

**Note 1:** Maximum output skew for any one device.

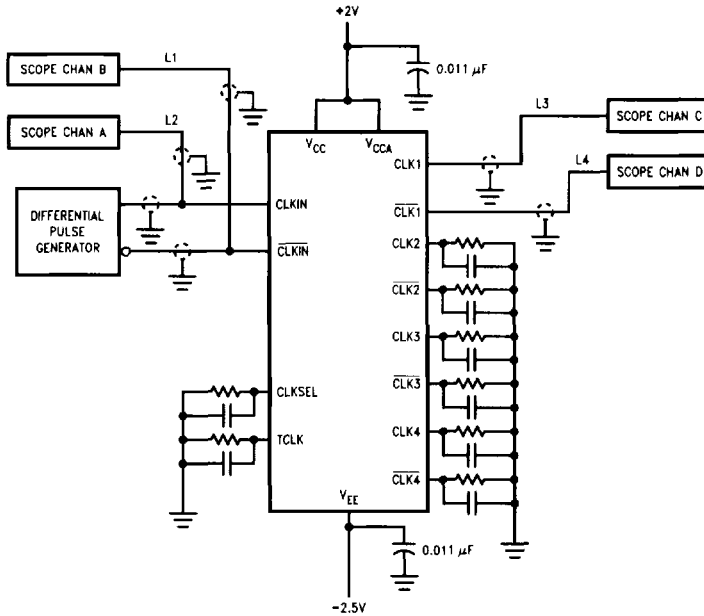

- Note 1:** Shown for testing CLKIN to CLK1 in the differential mode.
- Note 2:** L1, L2, L3 and L4 equal length 50Ω impedance lines.
- Note 3:** All unused inputs and outputs are loaded with 50Ω in parallel with  $\approx 3\ pF$  to GND.
- Note 4:** Scope should have 50Ω input terminator internally.

**FIGURE 1. AC Test Circuit**

TL/F/9842-3

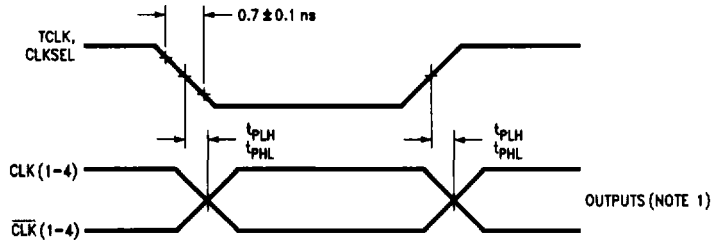

FIGURE 2. Propagation Delay, TCLK, CLKSEL to Outputs

TL/F/9842-4

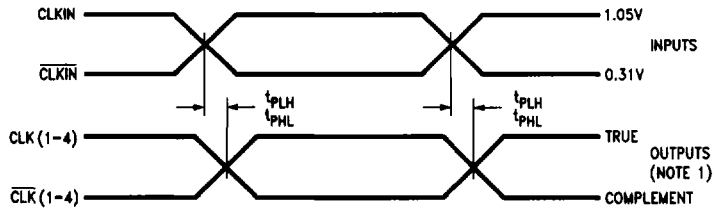

FIGURE 3. Propagation Delay, CLKIN/ $\overline{\text{CLKIN}}$  to Outputs

TL/F/9842-5

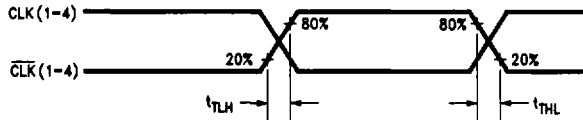

FIGURE 4. Transition Times

TL/F/9842-6

**Note 1:** The output to output skew, which is defined as the difference in the propagation delays between each of the four outputs on any one 100115 shall not exceed 75 ps.