



Dear customers,

About the change in the name such as "Oki Electric Industry Co. Ltd." and "OKI" in documents to OKI Semiconductor Co., Ltd.

The semiconductor business of Oki Electric Industry Co., Ltd. was succeeded to OKI Semiconductor Co., Ltd. on October 1, 2008. Therefore, please accept that although the terms and marks of "Oki Electric Industry Co., Ltd.", "Oki Electric", and "OKI" remain in the documents, they all have been changed to "OKI Semiconductor Co., Ltd.". It is a change of the company name, the company trademark, and the logo, etc. , and NOT a content change in documents.

October 1, 2008
OKI Semiconductor Co., Ltd.

OKI SEMICONDUCTOR CO., LTD.

550-1 Higashiasakawa-cho, Hachioji-shi, Tokyo 193-8550, Japan
<http://www.okisemi.com/en/>

MSC1937-01

14/16-Segment × 16-Digit Display Controller/Driver

GENERAL DESCRIPTION

MSC1937-01 is a Bi-CMOS alphanumeric display controller designed to interface with either vacuum fluorescent display.

MSC1937-01 can drive displays with up to 16 digits with either 14 or 16 segments plus a decimal point and comma.

MSC1937-01 provides the interface with the microcomputer only by two signal lines: DATA and SCLK.

FEATURES

- Can display up to 16 digits with either 14 or 16 segments plus comma/point.
- The number of display digits is programmable within 16.
- The brightness adjustment is programmable by 1/32 step.
- The display contents can be changed at any digit.
- Built-in PLA (64 types of ASCII characters (capital letters only) can be displayed).
- Executable in 1-byte instruction format
- Drive capability

Output current	:	Up to	-20 mA (Digit)	
			-10 mA (Segment)	: Plastic DIP
			-5 mA (Segment)	: Plastic QFP
- Withstand voltage : 58V
- Can also be used for LED.
- Pin compatible with 10937 manufactured by Rockwell.
- Supply voltage : 5V ± 10%
- Package options:
 - 40-pin plastic DIP (DIP40-P-600-2.54) (Product name: MSC1937-01RS)
 - 44-pin plastic QFP (QFP44-P-910-0.80-K) (Product name: MSC1937-01GS-K)

BLOCK DIAGRAM

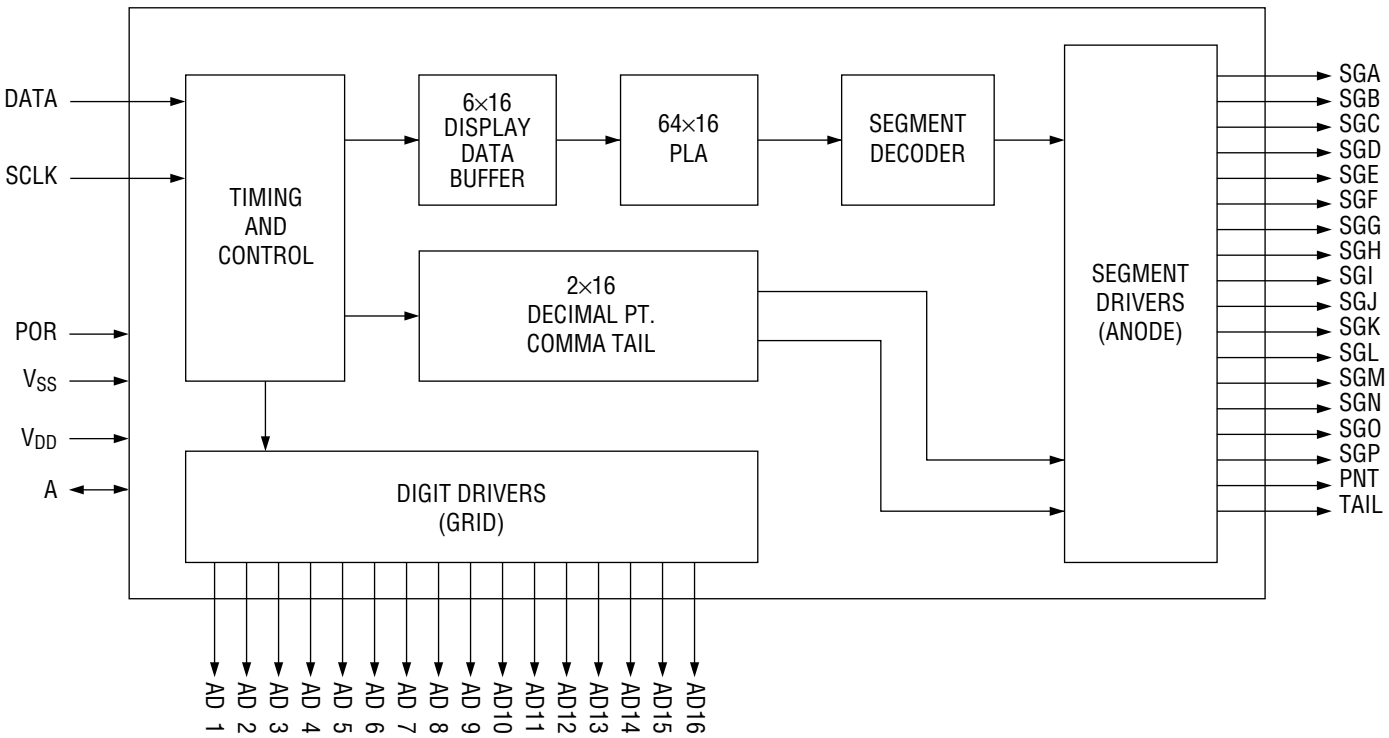

INPUT AND OUTPUT CONFIGURATION

- Schematic Diagrams of Logic Portion Input Circuit

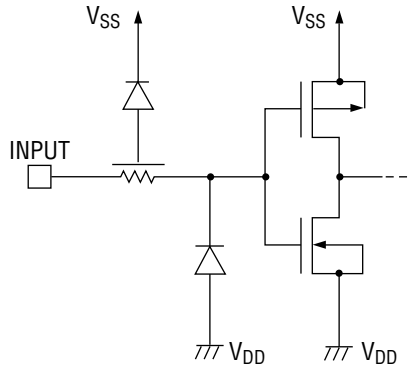

- Schematic Diagrams of Logic Portion Output Circuit



- Schematic Diagrams of Driver Output Circuit

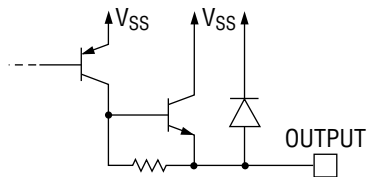

PIN CONFIGURATION (TOP VIEW)

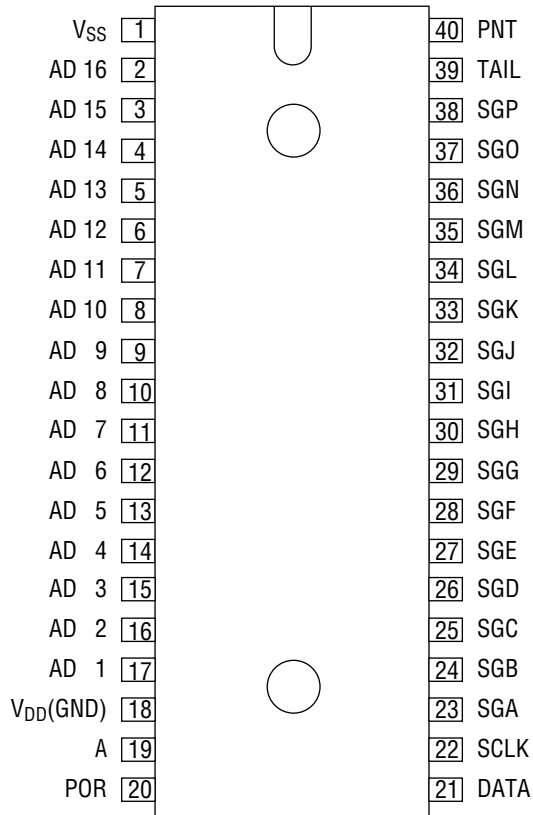

40-Pin Plastic DIP

Pin	Function
1	Power supply (5V)
2	Digit 16 output pin
⋮	⋮
17	Digit 1 output pin
18	GND
19	TEST pin
20	POWER-ON-RESET pin
21	Data input pin
22	Shift clock pin
23	Segment A output pin
⋮	⋮
38	Segment P output pin
39	TAIL output pin
40	POINT output pin

PIN CONFIGURATION (TOP VIEW)

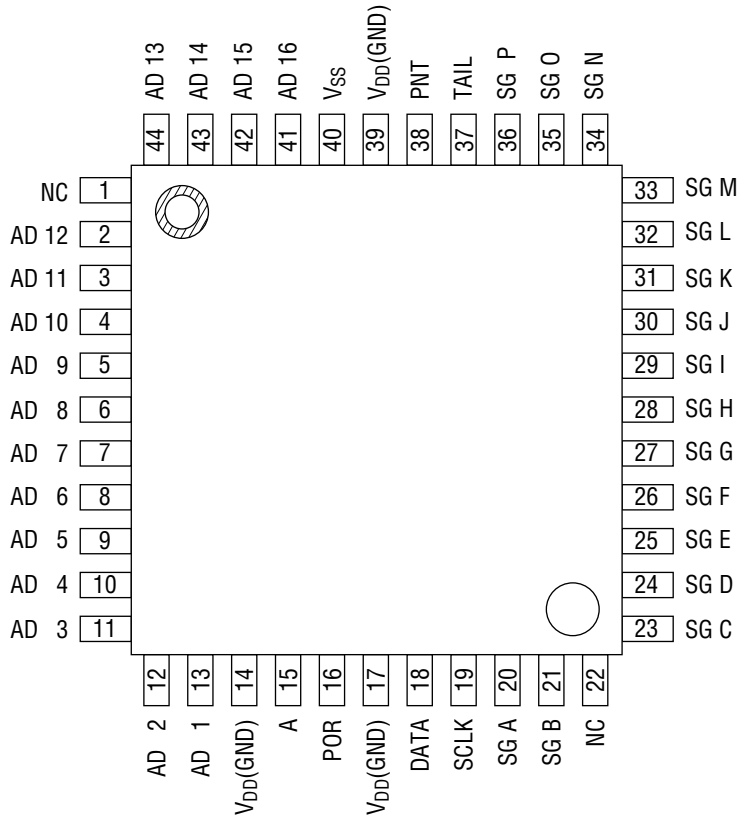

44-Pin Plastic QFP

Pin	Function	Pin	Function
1	No connection	22	No connection
2	Digit 12 output pin	23	Segment C output pin
⋮	⋮	⋮	⋮
13	Digit 1 output pin	36	Segment P output pin
14	GND	37	TAIL output pin
15	TEST pin	38	POINT output pin
16	POWER-ON-RESET pin	39	GND
17	GND	40	Power supply (5V)
18	Data input pin	41	Digit 16 output pin
19	Shift clock pin	⋮	⋮
20	Segment A output pin	44	Digit 13 output pin
21	Segment B output pin		

PIN DESCRIPTION

Symbol	Type	Description
V _{SS}	—	Power supply pin
V _{DD}	—	GND pin
DATA	I	Input of display data/control data Input from MSB
SCLK	I	Shift clock of shift register Shifts data at the falling edge of SCLK
POR	I	Power-on-reset input. Input of "H" level into this pin with the power turned on initializes this IC. The internal state after the initialization is as follows: 1) AD1 to AD16, SGA to SGP, TAIL and PNT output are in the off state. 2) The duty cycle is set to "0". 3) The digit counter value is set to 16 digits. 4) The buffer pointer is set to AD1. 5) Pin "A" is in the output mode.
A	I/O	Usually used as an output mode, and outputs 1/5 of the internal oscillation frequency. In the test mode, operates as an input pin.
AD16 - AD1	O	Grid output pins The output format is an emitter follower.
SGA - SGP TAIL, PNT	O	Segment output pins The output format is an emitter follower.

ABSOLUTE MAXIMUM RATINGS

Parameter	Symbol	Rating	Unit	
Power Supply Voltage	V_{SS}	-0.3 to +6.5	V	
Input Voltage	V_{IN}	-0.3 to $V_{SS} + 0.3$	V	
Output Voltage	V_{GG}	$V_{SS} - 58$ to $V_{SS} + 0.3$	V	
Output Current	I_{LOAD}	Digit	-25	
		Segment	DIP	-20
			QFP	-10
Storage Temperature	T_{STG}	-55 to +150	°C	

RECOMMENDED OPERATING CONDITIONS

Parameter	Symbol	Condition	Min.	Typ.	Max.	Unit
Power Supply Voltage	V_{SS}	—	4.5	—	5.5	V
"H" Input Voltage	V_{IH}	Applicable to all input pins	3.6	—	5.5	V
"L" Input Voltage	V_{IL}		0.0	—	1.0	V
Clock Frequency	f_C	—	—	—	500	kHz
Oscillation Frequency	f_{OSC}	—	—	500	—	kHz
Frame Frequency	f_{FR}	—	—	195	—	Hz
Operating Temperature	T_{op}	—	-40	—	85	°C

ELECTRICAL CHARACTERISTICS

DC Characteristics

($T_a = -40$ to $+85^\circ\text{C}$, $V_{SS} = 5\text{ V} \pm 10\%$, $V_{GG} = -53\text{ V} \pm 0.5\text{ V}$)

Parameter	Symbol	Condition		Min.	Max.	Unit
"H" Input Voltage	V_{IH}	Applicable to all input pins		3.6	5.5	V
"L" Input Voltage	V_{IL}			0.0	1.0	V
"H" Input Current	I_{IH}	$V_{IH} = V_{SS}$		-2.0	2.0	μA
"L" Input Current	I_{IL}	$V_{IL} = 0.0\text{ V}$		-2.0	2.0	μA
"H" Output Voltage	V_{OH1}	Digit	$V_{SS} = 5\text{ V}$ $I_{LOAD} = -10\text{mA}$	3.0	—	V
	V_{OH2}	Segment	DIP $V_{SS} = 5\text{ V}$ $I_{LOAD} = -10\text{mA}$	2.5	—	V
			QFP $V_{SS} = 5\text{ V}$ $I_{LOAD} = -5\text{mA}$	2.5	—	V
"L" Output Voltage	V_{OL}	"L" output current is determined by external pull-down resistor		—	$V_{GG}+3.0$	V
Output Leakage Current	I_{OUT}	$V_{OUT} = V_{SS} - V_{GG} = -53\text{ V}$		—	10.0	μA
Supply Current	I_{SS}	no-load		—	10.0	mA

AC Characteristics

($T_a = -40$ to $+85^\circ\text{C}$, $V_{SS} = 5\text{ V} \pm 10\%$, $V_{GG} = -53\text{ V} \pm 0.5\text{ V}$)

Parameter	Symbol	Condition	Min.	Max.	Unit	
Self Oscillation Frequency	f_{OSC}	—	392	548	kHz	
Frame Frequency	f_{FR}	—	88	332	Hz	
Clock Frequency	f_C	—	—	500	kHz	
SCLK "H" Time	t_{CW-H}	—	1.0	—	μs	
SCLK "L" Time	t_{CW-L}	—	1.0	—	μs	
Data Set-up Time	t_{DS}	—	200	—	ns	
Data Hold Time	t_{DH}	—	100	—	ns	
V_{SS} Rise Time	t_{PRZ}	When mounted in a unit		100	—	μs
POR Pulse Width	t_{RESW}	—	200	—	μs	
POR-SCLK Time	t_{RESS}	—	200	—	ns	
Internal Processing Time	t_{BUSY}	—	40	—	μs	

1) SCLK, Data Timing

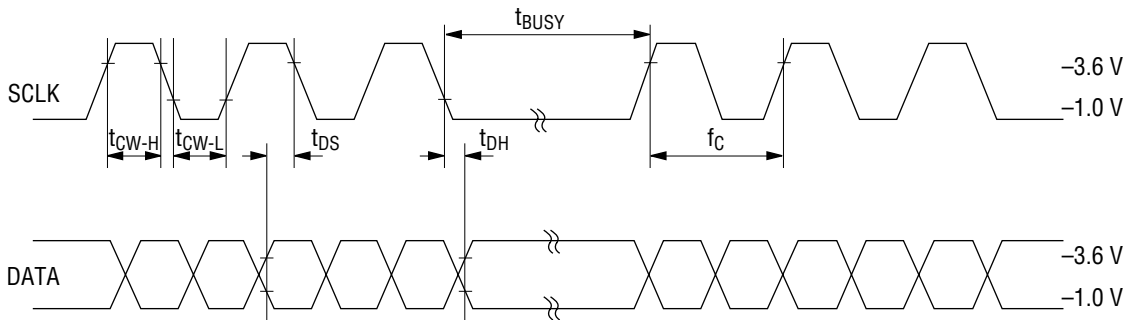

2) V_{SS} Set and Data Word Transfer Timing

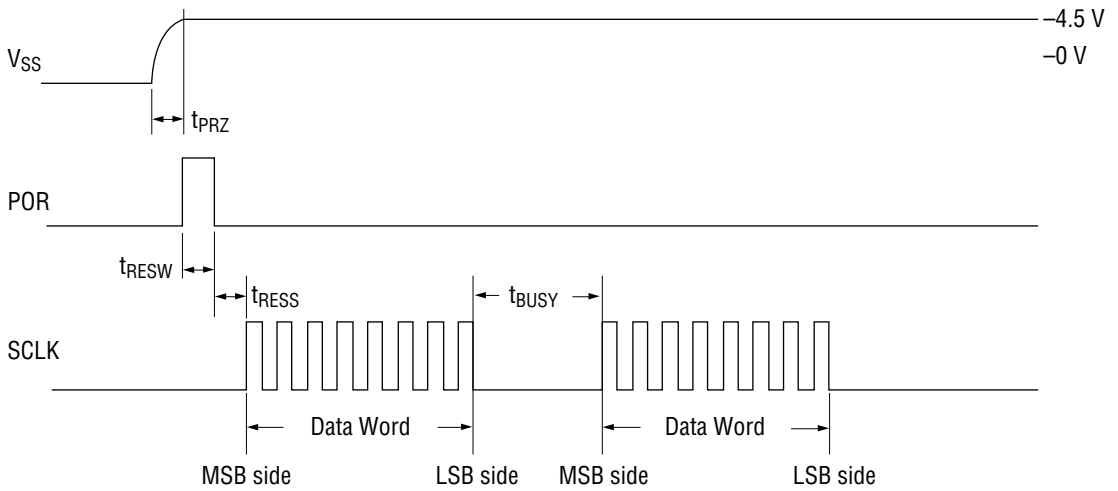

FUNCTIONAL DESCRIPTION

The MSB value of 8-bit serial data determines whether the input data into MSC1937-01 is control data or display data.

Display Data

By setting MSB = "0", the display data can be entered. The address of PLA is specified by bit 5 to bit 0 following MSB.

Table 1 provides the PLA code table.

Command	Function	MSB								LSB
		bit 7	bit 6	bit 5	bit 4	bit 3	bit 2	bit 1	bit 0	
Display Data	Sets the display contents	0	X	2 ⁵	2 ⁴	2 ³	2 ²	2 ¹	2 ⁰	

X: Don't care

Control Data

The control data can be input by setting MSB to "1". In addition, a command type and associated data with the command are determined by the bit 6 to bit 0.

Command	Function	MSB								LSB
		bit 7	bit 6	bit 5	bit 4	bit 3	bit 2	bit 1	bit 0	
Buffer Pointer Control	Specifies the RAM address.	1	0	1	0	2 ³	2 ²	2 ¹	2 ⁰	
Digit Counter Control	Sets the number of display digits.	1	1	0	0	2 ³	2 ²	2 ¹	2 ⁰	
Duty Cycle Control	Sets the duty value.	1	1	1	2 ⁴	2 ³	2 ²	2 ¹	2 ⁰	
Test Mode	Sets the test mode.	1	0	0	2 ⁴	X	X	X	X	

X: Don't care

a) Buffer Pointer Control

This command changes the display contents only at an arbitrary digit. (The RAM write address is set.)

A decimal equivalent value of bits 0 - 3 should be set (desired digit number -2).

(Example) When specifying AD4, the set value is 2 (0010).

Specified Digit	Set Value of Bits 0 to 3	Specified Digit	Set Value of Bits 0 to 3
AD1	15 (1111)	AD9	7 (0111)
AD2	0 (0000)	AD10	8 (1000)
AD3	1 (0001)	AD11	9 (1001)
AD4	2 (0010)	AD12	10 (1010)
AD5	3 (0011)	AD13	11 (1011)
AD6	4 (0100)	AD14	12 (1100)
AD7	5 (0101)	AD15	13 (1101)
AD8	6 (0110)	AD16	14 (1110)

b) Digit Counter Control

This command sets the number of display digits.
Set the desired number of digits in bits 0 to 3.

Number of Display Digits	Set Value of Bits 0 to 3	Number of Display Digits	Set Value of Bits 0 to 3
1	1 (0001)	9	9 (1001)
2	2 (0010)	10	10 (1010)
3	3 (0011)	11	11 (1011)
4	4 (0100)	12	12 (1100)
5	5 (0101)	13	13 (1101)
6	6 (0110)	14	14 (1110)
7	7 (0111)	15	15 (1111)
8	8 (1000)	16	0 (0000)

c) Duty Cycle Control

This command sets the duty cycle of the driver output. This command allows the brightness to be adjusted by 1/32 step. As shown in Figure 1, the blank time between digits or between the segments is specified by 1 bit time on the hardware. Therefore, the set value ranges from 0 to 31.

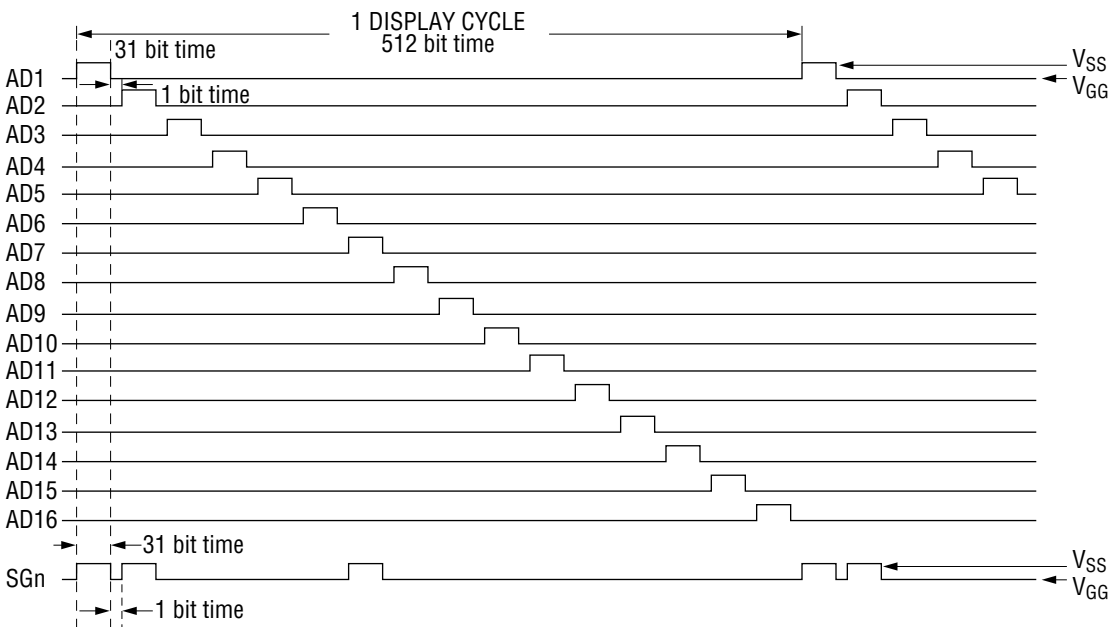

Shown above is the timing when Duty Cycle = 31 (1 bit time = $5 \times 1/f_{OSC}$)

Fig. 1 Output Timing

d) Test Mode

This mode is not a user function, but is used for outgoing inspection.

Table 1 PLA Code Table

00		08		10		18		20		28		30		38	
01		09		11		19		21		29		31		39	
02		0A		12		1A		22		2A		32		3A	
03		0B		13		1B		23		2B		33		3B	
04		0C		14		1C		24		2C		34		3C	
05		0D		15		1D		25		2D		35		3D	
06		0E		16		1E		26		2E		36		3E	
07		0F		17		1F		27		2F		37		3F	

16-Segment Display

00		08		10		18		20		28		30		38	
01		09		11		19		21		29		31		39	
02		0A		12		1A		22		2A		32		3A	
03		0B		13		1B		23		2B		33		3B	
04		0C		14		1C		24		2C		34		3C	
05		0D		15		1D		25		2D		35		3D	
06		0E		16		1E		26		2E		36		3E	
07		0F		17		1F		27		2F		37		3F	

14-Segment Display

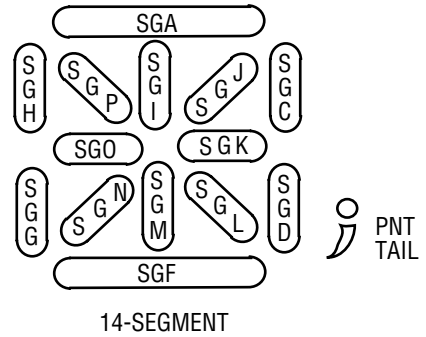
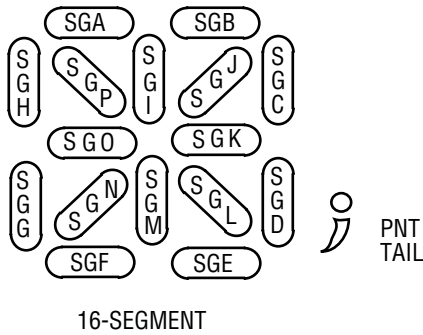

* To set the comma and decimal point, the display data at the display digit is input, then 2C and 2E data is input.

Note: Only when 2C and 2E data is entered, the write address in the RAM is not automatically incremented. For other data, the address specified by the Buffer Pointer Control command is automatically incremented by one each time the display data is input.

APPLICATION CIRCUITS

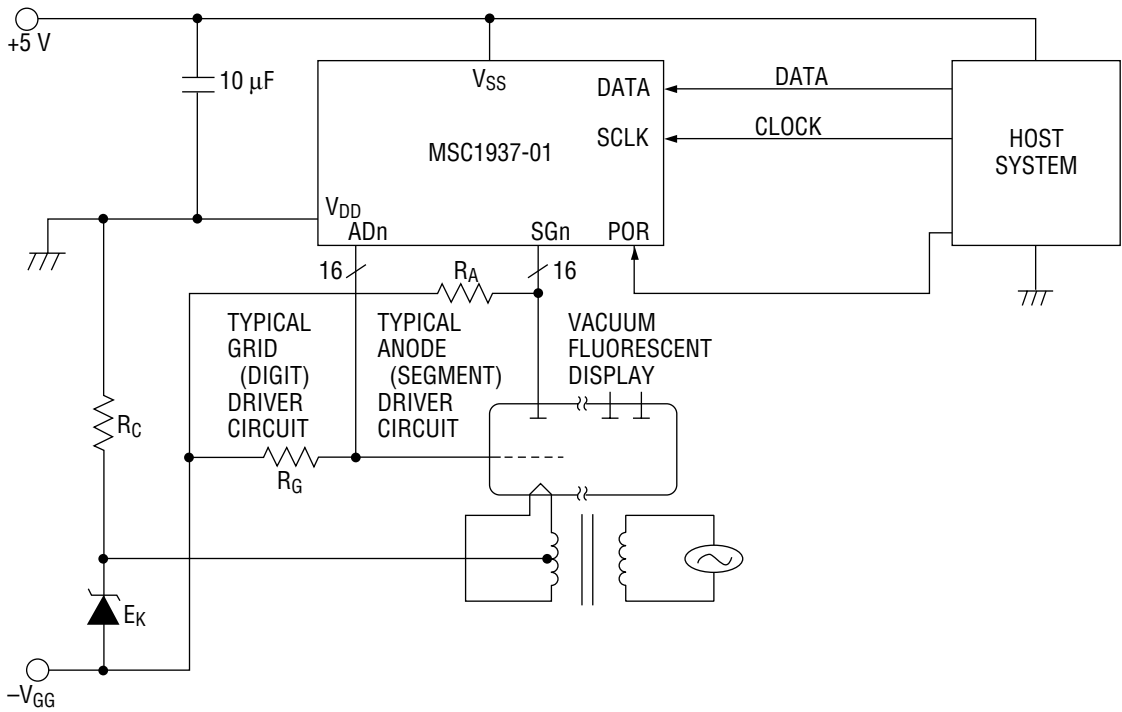

PACKAGE DIMENSIONS

(Unit : mm)

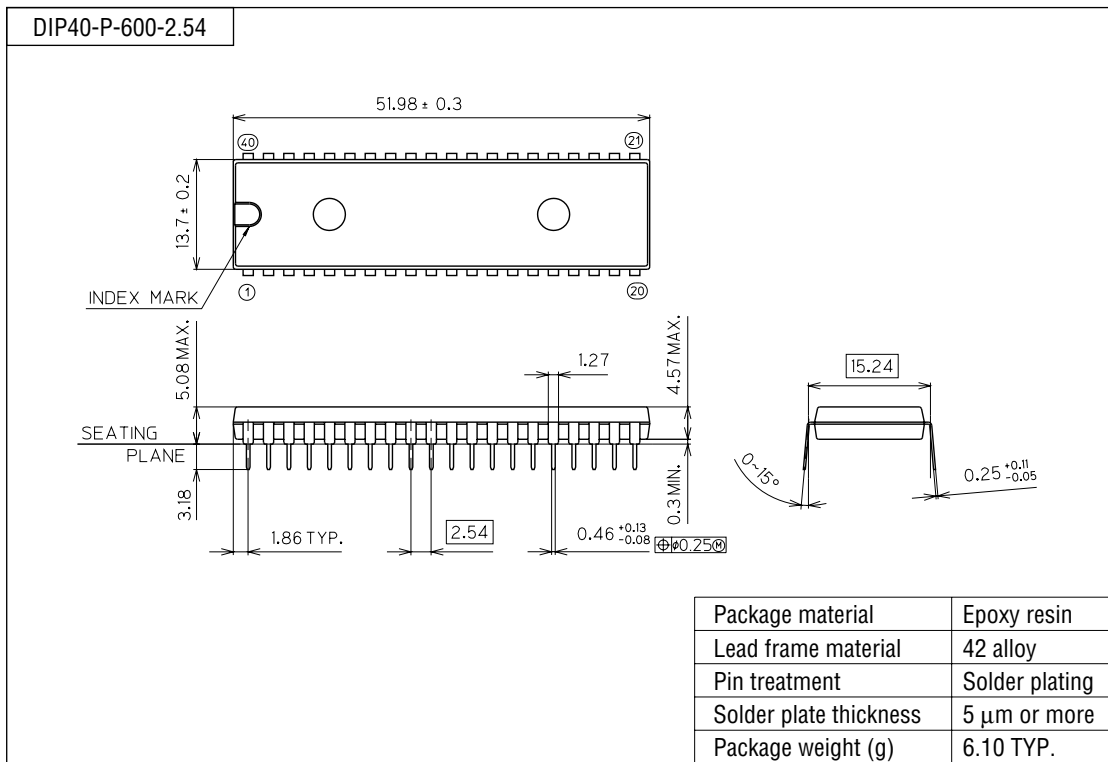

Notes for Mounting the Surface Mount Type Package

The SOP, QFP, TSOP, SOJ, QFJ (PLCC), SHP and BGA are surface mount type packages, which are very susceptible to heat in reflow mounting and humidity absorbed in storage. Therefore, before you perform reflow mounting, contact Oki's responsible sales person for the product name, package name, pin number, package code and desired mounting conditions (reflow method, temperature and times).

(Unit : mm)

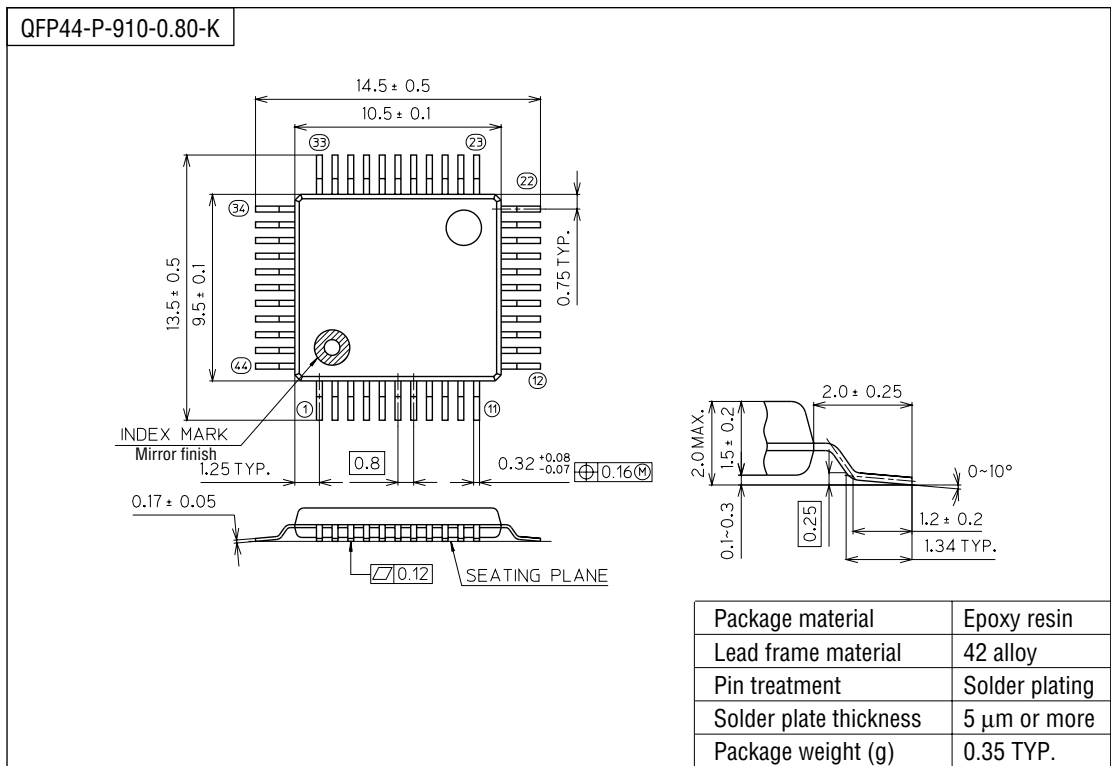

Notes for Mounting the Surface Mount Type Package

The SOP, QFP, TSOP, SOJ, QFJ (PLCC), SHP and BGA are surface mount type packages, which are very susceptible to heat in reflow mounting and humidity absorbed in storage.

Therefore, before you perform reflow mounting, contact Oki's responsible sales person for the product name, package name, pin number, package code and desired mounting conditions (reflow method, temperature and times).