

TOSHIBA HYBRID DIGITAL INTEGRATED CIRCUIT

16,777,216-WORD BY 64-BIT SYNCHRONOUS DRAM MODULE

DESCRIPTION

The THLY641681FG is a 16,777,216-word by 64-bit synchronous dynamic RAM module consisting of eight TC59SM716FT/FTL DRAMs on a printed circuit board.

FEATURES

- 16,777,216-word by 64-bit organization
- Single power supply of 3.3 V \pm 0.3 V
- Pipeline architecture
- Auto-refresh and Self-refresh capability
- All inputs and outputs LVTTTL-compatible
- 4096 refresh cycles per 64 ms
- Package: 144-pin small-outline DIMM (gold contacts)
- JEDEC Standard

	-80	-10
t _{CK} Clock Cycle Time (CL = 2)	10 ns	12 ns
t _{TRAS} Active-to-Precharge Command Period (min)	48 ns	60 ns
t _{AC} Access Time from CLK (CL = 2)	6 ns	8 ns
t _{RC} Ref/Active-to-Ref/Active Command Period (min)	68 ns	84 ns

PIN ASSIGNMENT

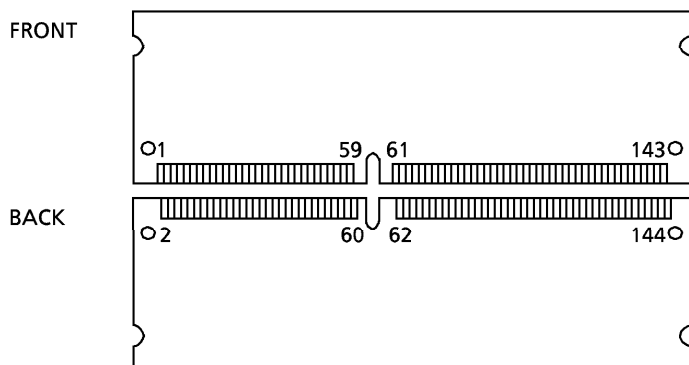

PIN NAMES

A0 to A11	Address Inputs
BA0, 1	Bank Select
DQ0 to DQ63	Data Inputs/Outputs
/CS0, /CS1	Chip Select
/RAS	Row Address Strobe
/CAS	Column Address Strobe
/WE	Write Enable
DQMB0 to 7	Output Disable / Write Mask
CLK0, 1	Clock Input
CKE0, 1	Clock Enable
SDA	Serial Data/Address for PD
SCL	Clock for PD
VDD	Power (+ 3.3 V)
VSS	Ground
NC	No Connection

1	VSS	2	VSS	49	DQ13	50	DQ45	97	DQ22	98	DQ54
3	DQ0	4	DQ32	51	DQ14	52	DQ46	99	DQ23	100	DQ55
5	DQ1	6	DQ33	53	DQ15	54	DQ47	101	VDD	102	VDD
7	DQ2	8	DQ34	55	VSS	56	VSS	103	A6	104	A7
9	DQ3	10	DQ35	57	NC	58	NC	105	A8	106	BA0
11	VDD	12	VDD	59	NC	60	NC	107	VSS	108	VSS
13	DQ4	14	DQ36	61	CLK0	62	CKE0	109	A9	110	BA1
15	DQ5	16	DQ37	63	VDD	64	VDD	111	A10	112	A11
17	DQ6	18	DQ38	65	/RAS	66	/CAS	113	VDD	114	VDD
19	DQ7	20	DQ39	67	/WE	68	CKE1	115	DQMB2	116	DQMB6
21	VSS	22	VSS	69	/CS0	70	NC	117	DQMB3	118	DQMB7
23	DQMB0	24	DQMB4	71	/CS1	72	NC	119	VSS	120	VSS
25	DQMB1	26	DQMB5	73	NC	74	CLK1	121	DQ24	122	DQ56
27	VDD	28	VDD	75	VSS	76	VSS	123	DQ25	124	DQ57
29	A0	30	A3	77	NC	78	NC	125	DQ26	126	DQ58
31	A1	32	A4	79	NC	80	NC	127	DQ27	128	DQ59
33	A2	34	A5	81	VDD	82	VDD	129	VDD	130	VDD
35	VSS	36	VSS	83	DQ16	84	DQ48	131	DQ28	132	DQ60
37	DQ8	38	DQ40	85	DQ17	86	DQ49	133	DQ29	134	DQ61
39	DQ9	40	DQ41	87	DQ18	88	DQ50	135	DQ30	136	DQ62
41	DQ10	42	DQ42	89	DQ19	90	DQ51	137	DQ31	138	DQ63
43	DQ11	44	DQ43	91	VSS	92	VSS	139	VSS	140	VSS
45	VDD	46	VDD	93	DQ20	94	DQ52	141	SDA	142	SCL
47	DQ12	48	DQ44	95	DQ21	96	DQ53	143	VDD	144	VDD

980910EBA1

- TOSHIBA is continually working to improve the quality and the reliability of its products. Nevertheless, semiconductor devices in general can malfunction or fail due to their inherent electrical sensitivity and vulnerability to physical stress. It is the responsibility of the buyer, when utilizing TOSHIBA products, to observe standards of safety, and to avoid situations in which a malfunction or failure of a TOSHIBA product could cause loss of human life, bodily injury or damage to property. In developing your designs, please ensure that TOSHIBA products are used within specified operating ranges as set forth in the most recent products specifications. Also, please keep in mind the precautions and conditions set forth in the TOSHIBA Semiconductor Reliability Handbook.
- The products described in this document are subject to the foreign exchange and foreign trade laws.
- The information contained herein is presented only as a guide for the applications of our products. No responsibility is assumed by TOSHIBA CORPORATION for any infringements of intellectual property or other rights of the third parties which may result from its use. No license is granted by implication or otherwise under any intellectual property or other rights of TOSHIBA CORPORATION or others.
- The information contained herein is subject to change without notice.

Serial Presence Detect (Rev.1.2A)

Byte Number	Function Described	-80		-10	
		Entry Value	Entry	Entry Value	Entry
0	Defines # bytes Written into Serial Memory at Module mfg	128bytes	80h	128bytes	80h
1	Total # bytes of SPD Memory Device	256bytes	08h	256bytes	08h
2	Fundamental Memory Type (FPM, EDO, SDRAM...) from Appendix A	SDRAM	04h	SDRAM	04h
3	# Row Addresses on this Assembly	RA0-RA11	0Ch	RA0-RA11	0Ch
4	# Column Addresses on this Assembly	CA0-CA8	09h	CA0-CA8	09h
5	# Module Banks on this Assembly	2Bank	02h	2Bank	02h
6	Data Width of this Assembly...	x64	40h	x64	40h
7	...Data Width Continuation	x64	00h	x64	00h
8	Voltage Interface Standard of this Assembly	LVTTL	01h	LVTTL	01h
9	SDRAM Cycle Time at Max. Supported CAS Latency (CL), CL = X	CL = 3, 8.0 ns	80h	CL = 3, 10 ns	A0h
10	SDRAM Access from Clock @ CL = X	CL = 3, 6.0 ns	60h	CL = 3, 7.0 ns	70h
11	DIMM Configuration Type (Non-parity, Parity, ECC)	Non-Parity	00h	Non-Parity	00h
12	Refresh Rate/Type	15.625 μ s/self	80h	15.625 μ s/self	80h
13	SDRAM Width, Primary DRAM	x16	10h	x16	10h
14	Error Checking SDRAM Data Width	N/A	00h	N/A	00h
15	Minimum Clock Delay, Back to Back Random Column Addresses	1CLK	01h	1CLK	01h
16	Burst Lengths Supported	1,2,4,8 Full page	8Fh	1,2,4,8 Full page	8Fh
17	# Banks on each SDRAM Device	4Bank	04h	4Bank	04h
18	CAS # Latencies Supported	2,3	06h	2,3	06h
19	CS # Latency		01h		01h
20	WE # Latency		01h		01h
21	SDRAM Module Attributes		00h		00h
22	SDRAM Device Attributes: General		0Eh		0Eh
23	Minimum Clock Cycle Time at CL- X-1	CL = 2, 10 ns	A0h	CL = 2, 12 ns	C0h
24	Maximum Data Access Time from Clock @ CL X-1	CL = 2, 6.0 ns	60h	CL = 2, 8.0 ns	80h
25	Minimum Clock Cycle Time at CL X-2		00h		00h
26	Maximum Data Access Time from Clock @ CL X-2		00h		00h
27	Minimum Row Precharge Time	20ns	14h	24 ns	18h
28	Minimum Row Active to Row Active Delay	20 ns	14h	20 ns	14h
29	Minimum RAS to CAS Delay	20 ns	14h	24 ns	18h
30	Minimum RAS Pulse Width	48 ns	30h	60 ns	3Ch
31	Module/Bank Density	64 MB	10h	64 MB	10h
32	Command & Address signal Input Setup Time	2 ns	20h	2.5 ns	25h
33	Command & Address Signal Input Hold Time	1 ns	10h	1 ns	10h
34	Data signal Input Setup Time	2 ns	20h	2.5 ns	25h
35	Data signal Input Hold Time	1 ns	10h	1 ns	10h
36-61	Superset Information (may be used in future)		FFh		FFh
62	SPD Revision	Rev.1.2A	12h	Rev.1.2A	12h
63	Checksum for bytes 0-62	1ED2h	D2h	1F60h	60h

Option

64	Manufacturers JEDEC ID Code per JEP-106E				
65-71	Manufacturing Location				
72	Manufacturer's Part Number				
73-90	Revision Code				
91-92	Manufacturing Date				
93-94	Assembly Serial Number				
95-98	Manufacturer Specific Data				
99-125	Reserved	Intel Specification	66h	Intel Specification	66h
126	Reserved	Intel Specification	C7h	Intel Specification	C7h
127					
128-255					

BLOCK DIAGRAM

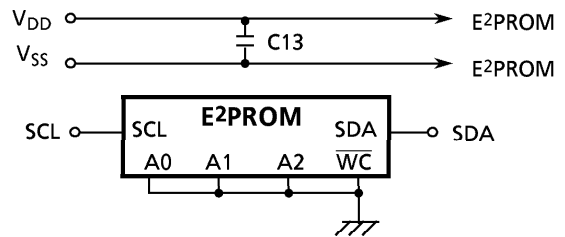
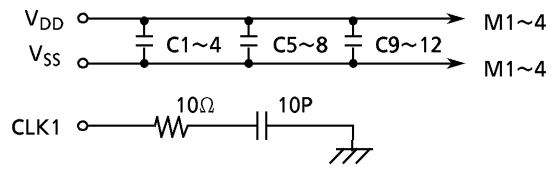
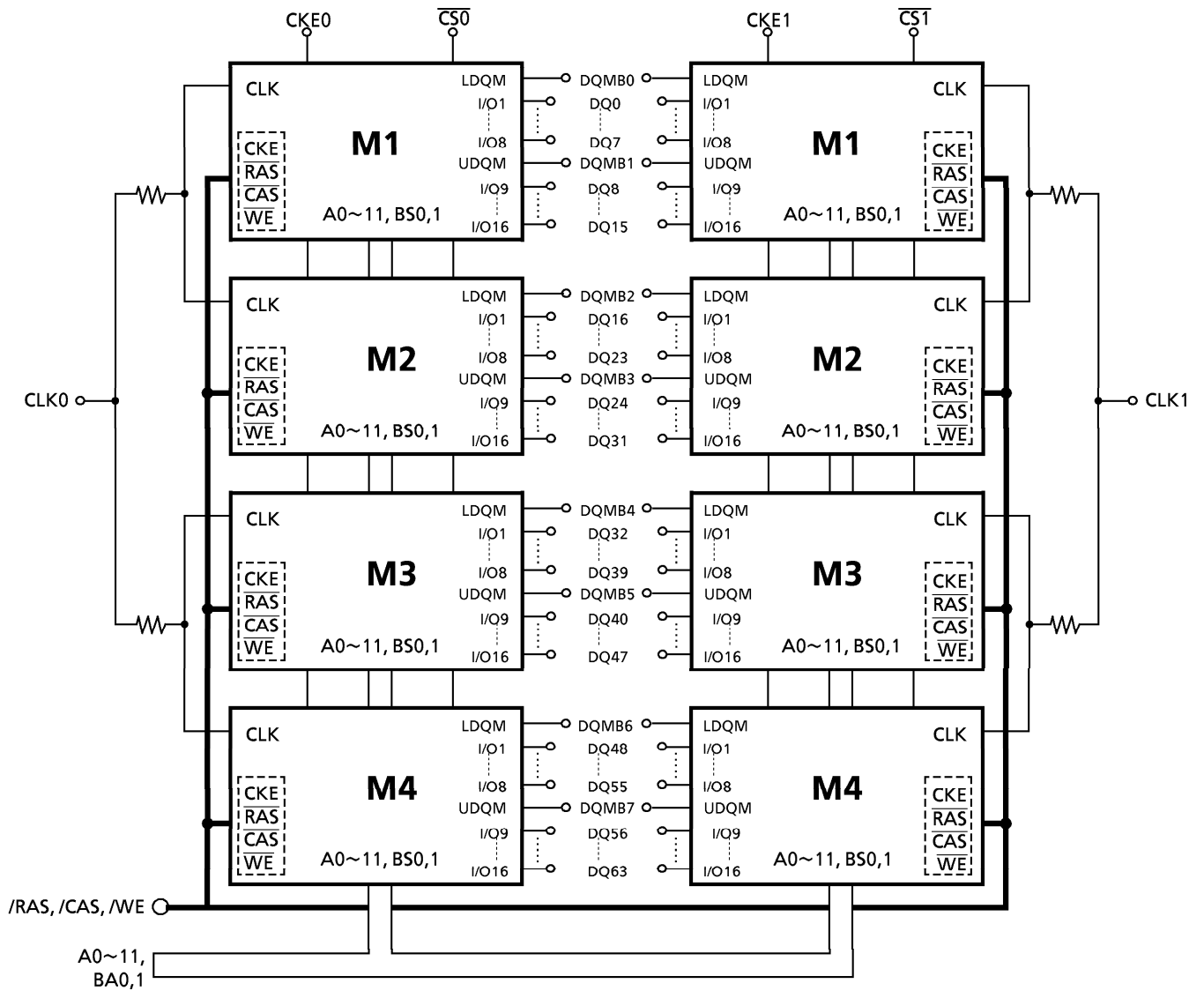

ABSOLUTE MAXIMUM RATINGS

SYMBOL	ITEM	RATING	UNIT	NOTES
V _{IN}	Input Voltage	- 0.5 to V _{DD} + 0.3	V	1
V _{OUT}	Output Voltage	- 0.5 to V _{DD} + 0.3	V	1
V _{DD}	Power Supply Voltage	- 0.5 to 4.6	V	1
T _{OPR}	Operating Temperature	0 to 70	°C	1
T _{STG}	Storage Temperature	- 55 to 125	°C	1
P _D	Power Dissipation	2.4	W	1
I _{OUT}	Short Circuit Output Current	50	mA	1

RECOMMENDED DC OPERATING CONDITIONS (Ta = 0° to 70°C)

SYMBOL	PARAMETER	MIN	TYP.	MAX	UNIT	NOTES
V _{DD}	Supply Voltage	3.0	3.3	3.6	V	2
V _{IH}	LVTTTL Input High Voltage	2.0	-	V _{DD} + 0.3	V	2
V _{IL}	LVTTTL Input Low Voltage	- 0.5	-	0.8	V	2

CAPACITANCE (V_{DD} = 3.3 V, f = 1 MHz, Ta = 0° to 70°C)

SYMBOL	PARAMETER	MIN	MAX	UNIT
C ₁	Input Capacitance (A0 to A11)	-	50.0	pF
C ₂	Input Capacitance (RAS, CAS, WE)	-	50.0	pF
C ₃	Input Capacitance (CLK0,1)	-	40.0	pF
C ₄	Input Capacitance (CS0)	-	35.0	pF
C ₅	Input Capacitance (DQMB0 to 7)	-	20.0	pF
C _{DQ}	I/O Capacitance (DQ0 to DQ63)	-	20.0	pF

DC CHARACTERISTICS ($V_{DD} = 3.3\text{ V} \pm 0.3\text{ V}$, $T_a = 0^\circ$ to 70°C)

SYMBOL	ITEM	-80		-10		UNIT	NOTES	
		MIN	MAX	MIN	MAX			
I_{CC1}	OPERATING CURRENT Active-Precharge Command Cycling without Burst Operation, 1-Bank Operation ($t_{CK} = t_{RC}$ min)	1 Row Operation	-	480	-	420	mA	3, 5
I_{CC1B}								
I_{CC2}	STANDBY CURRENT ($t_{CK} = \text{min}$, $\overline{CS} = V_{IH}$, $V_{IH/L} = V_{IH}(\text{min}) / V_{IL}(\text{max})$ Bank: Inactive State)	$CKE = V_{IH}$	-	320	-	280	mA	3
I_{CC2P}		$CKE = V_{IL}$ (Power-down Mode)	-	8	-	8		
I_{CC2S}	STANDBY CURRENT ($CLK = V_{IL}$, $\overline{CS} = V_{IH}$, $V_{IH/L} = V_{IH}(\text{min}) / V_{IL}(\text{max})$ Bank: Inactive State)	$CKE = V_{IH}$	-	80	-	80	mA	
I_{CC2PS}		$CKE = V_{IL}$ (Power-down Mode)	-	8	-	8		
I_{CC3}	NO OPERATING CURRENT ($t_{CK} = \text{min}$, $\overline{CS} = V_{IH}(\text{min})$ Bank: Active State (2 Banks))	$CKE = V_{IH}$	-	360	-	320	mA	
I_{CC3P}		$CKE = V_{IL}$ (Power-down Mode)	-	80	-	80		
I_{CC4}	BURST OPERATING CURRENT ($t_{CK} = \text{min}$, $\overline{CS} = V_{IH}(\text{min})$ Read / Write Command Cycling)		-	600	-	500	mA	3, 4
I_{CC5}	AUTO-REFRESH CURRENT ($t_{CK} = \text{min}$, Auto-Refresh Command Cycling)		-	1440	-	720	mA	3
I_{CC6}	SELF-REFRESH CURRENT (Self-Refresh Mode, $CKE = 0.2\text{ V}$)	THLY641681FG-80,-10	-	16	-	16	mA	3
		THLY641681FG-80L,-10L	-	6.4	-	6.4		
$I_{I(L)}$	INPUT LEAKAGE CURRENT ($0\text{ V} \leq V_{IN} \leq V_{DD}$, All Other Pins Not under Test = 0 V)		-5	5	-5	5	μA	
$I_{O(L)}$	OUTPUT LEAKAGE CURRENT (D_{OUT} Is Disabled, $0\text{ V} \leq V_{OUT} \leq V_{DD}$)		-5	5	-5	5	μA	
V_{OH}	OUTPUT LEVEL LVTTTL Output H Level Voltage ($I_{OUT} = -2\text{ mA}$)		2.4	-	2.4	-	V	
V_{OL}	OUTPUT LEVEL LVTTTL Output L Level Voltage ($I_{OUT} = 2\text{ mA}$)		-	0.4	-	0.4	V	

AC CHARACTERISTICS AND RECOMMENDED OPERATING CONDITIONS

($V_{DD} = 3.3\text{ V} \pm 0.3\text{ V}$, $T_a = 0^\circ$ to 70°C)

SYMBOL	PARAMETER	-80		-10		UNIT	NOTES	
		MIN	MAX	MIN	MAX			
t _{RC}	Ref/Active-Ref/Active Command Period	68		84		ns	9	
t _{RAS}	Active- Precharge Command Period	48	100000	60	100000			
t _{RCD}	Active-Read/Write Command Delay Time	20		24				
t _{CCD}	Read/Write(a) -Read/Write(b) Command Period	1		1		cycle		
t _{RP}	Precharge-Active Command Period	20		24		ns		
t _{RRD}	Active(a)-Active(b) Command Period	20		20				
t _{WR}	Write Recovery Time	CL* = 2	10		12			
		CL* = 3	8		10			
t _{CK}	CLK Cycle Time	CL* = 2	10	1000	12			1000
		CL* = 3	8	1000	10			1000
t _{CH}	CLK High Level Width	3		3				10
t _{CL}	CLK Low Level Width	3		3				
t _{AC}	Access Time from CLK	CL* = 2		6				8
		CL* = 3		6				7
t _{OH}	Output Data Hold Time	3		3				8
t _{HZ}	Output Data High Impedance Time	3	8	3	10			
t _{LZ}	Output Data Low Impedance Time	0		0				
t _{SB}	Power-down Mode Entry Time	0	8	0	10			
t _T	Transition Time of CLK (Rise and Fall)	0.5	10	0.5	10			
t _{DS}	Data-in Set-up Time	2		2.5				
t _{DH}	Data-in Hold Time	1		1				
t _{AS}	Address Set-up Time	2		2.5				
t _{AH}	Address Hold Time	1		1				
t _{CKS}	CKE Set-up Time	2		2.5				
t _{CKH}	CKE Hold Time	1		1				
t _{CMS}	Command Set-up Time	2		2.5				
t _{CMH}	Command Hold Time	1		1				
t _{REF}	Refresh Time		64		64	ms		
t _{RSC}	Mode Register Set Cycle Time	16		20		ns	9	

* CL is $\overline{\text{CAS}}$ latency.

NOTES:

1. Conditions outside the limits listed under Absolute Maximum Ratings may cause permanent damage to the device.
2. All voltages are referenced to Vss.
3. These parameters depend on the cycle rate and their values are measured at the minimum cycle rate values t_{CK} and t_{RC} . Input signals are changed once during t_{CK} .
4. These parameters depend on the output loading. The specified values are obtained with the output open.
5. These values are measured with the following conditions.
 - Front side (or back side) : the measuring condtions on the data sheet
 - Back side (or front side) : Stand by (measured with I_{CC2} conditions)
6. The power-up sequence is described in Note 12.
7. **AC TEST CONDITIONS**

Reference Level of Output Signals	1.4 V/1.4 V
Output Load	See the diagram for AC Test Load (B) below
Input Signal Levels	2.4 V/0.4 V
Transition Time (Rise and Fall) of Input Signals	2 ns
Reference Level of Input Signals	1.4 V

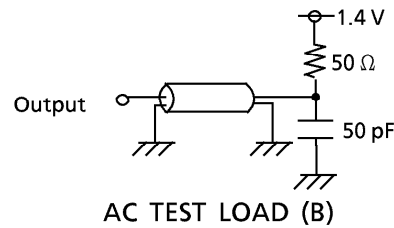
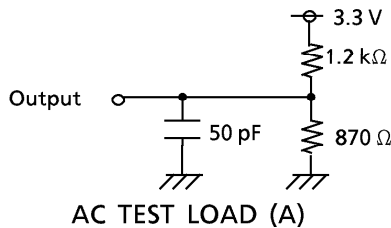

8. Transition times are measured between the V_{IH} and V_{IL} levels. Transition (rise and fall) of input signals has a fixed slope.
9. t_{HZ} defines the time at which the outputs go open circuit and are not reference levels.
10. These parameters depend on the number of clock cycles and depend on the operating frequency of the clock as follows:
 - Number of clock cycles = Specified value of timing / Clock period
 - (Round up fractions to a whole number.)

11. t_{CH} is the pulse width of CLK measured from the positive edge to the negative edge and referenced to V_{IH} (min). t_{CL} is the pulse width of CLK measured from the negative edge to the positive edge and referenced to V_{IL} (max).
12. Power-up Sequence
Power-up must be performed in the following sequence.
 - 1) Power must be applied to V_{DD} and V_{DDQ} (simultaneously) with all input signals held in the NOP state. The CLK signal must be started at the same time as power is applied.
 - 2) After power-up a pause of at least 200μ seconds is required. Then, DQM and CKE must be held High (at the V_{DD} level) to ensure that the DQ output is high-impedance.
 - 3) Both banks must be precharged.
 - 4) The Mode Register Set command must be asserted to initialize the Mode register.
 - 5) An Auto-Refresh operation must consist of at least eight Auto-Refresh cycles.
The order in which 4) and 5) are performed is interchangeable.

TIMING DIAGRAMS

Read Timing

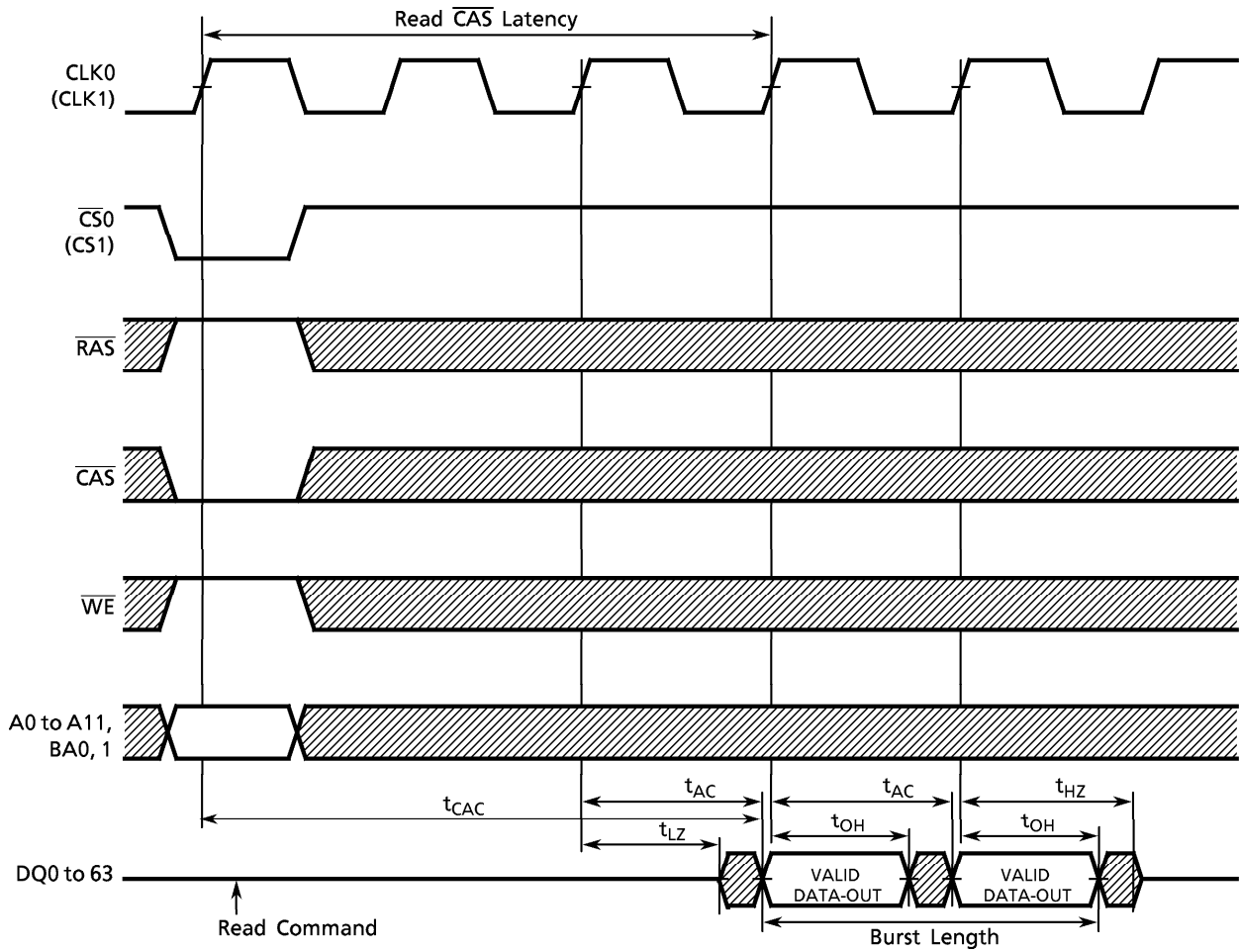

Command Input Timing

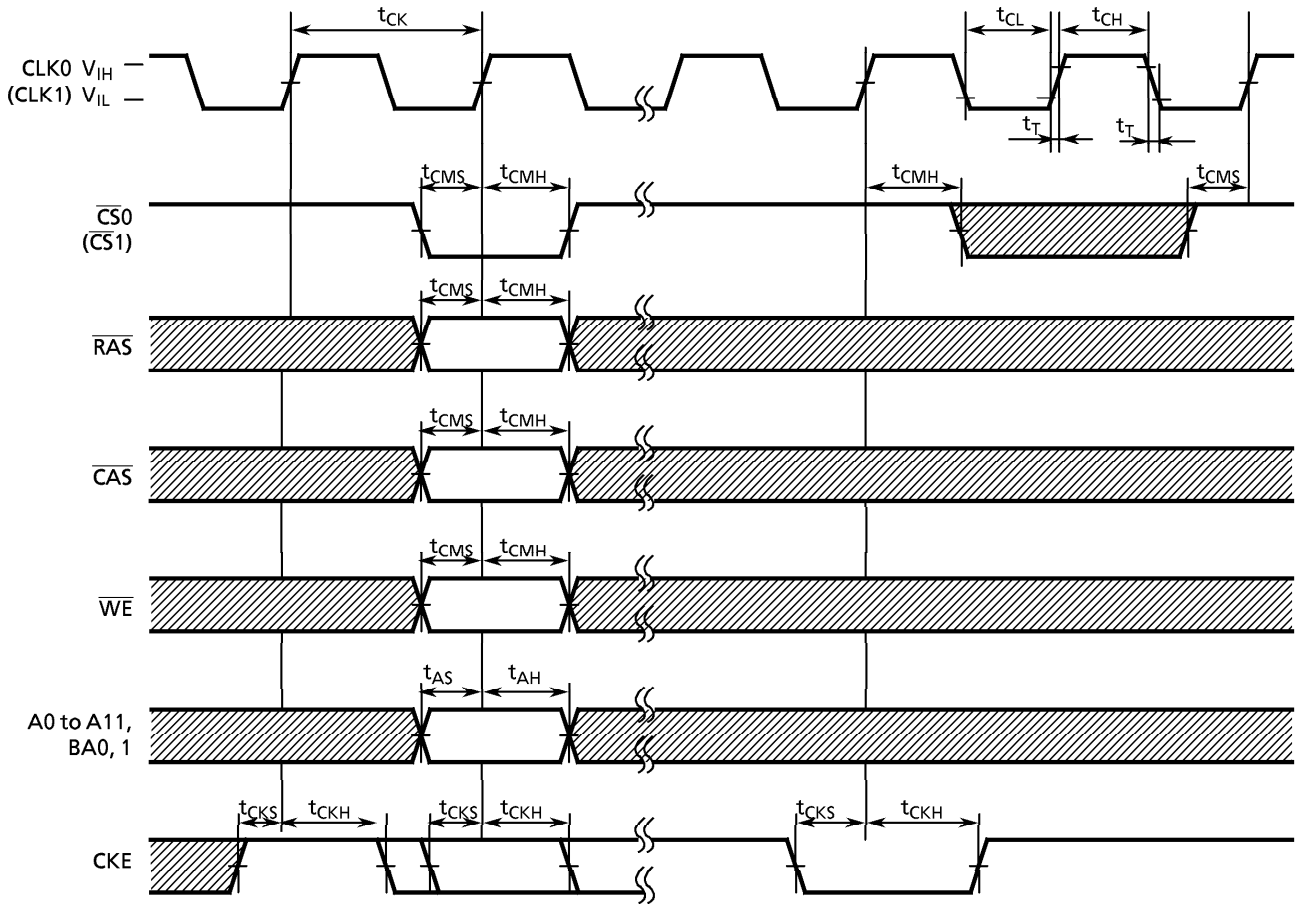

Control Timing for Input Data

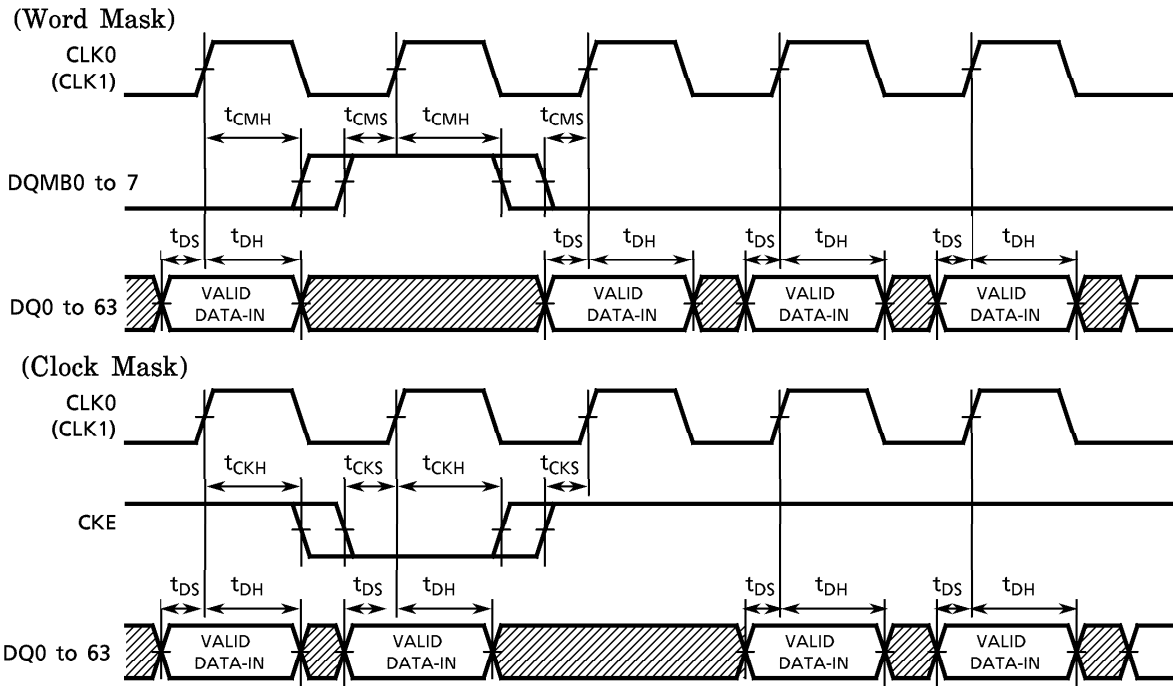

Control Timing for Output Data

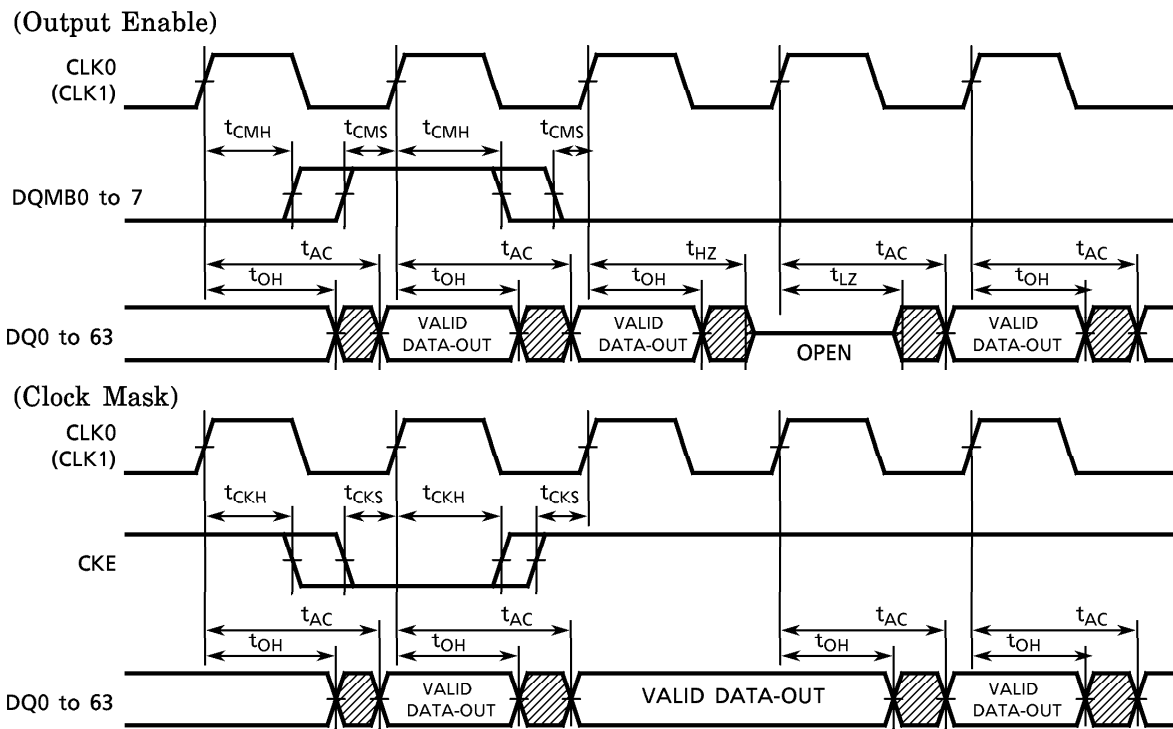

Mode Register Set Cycle

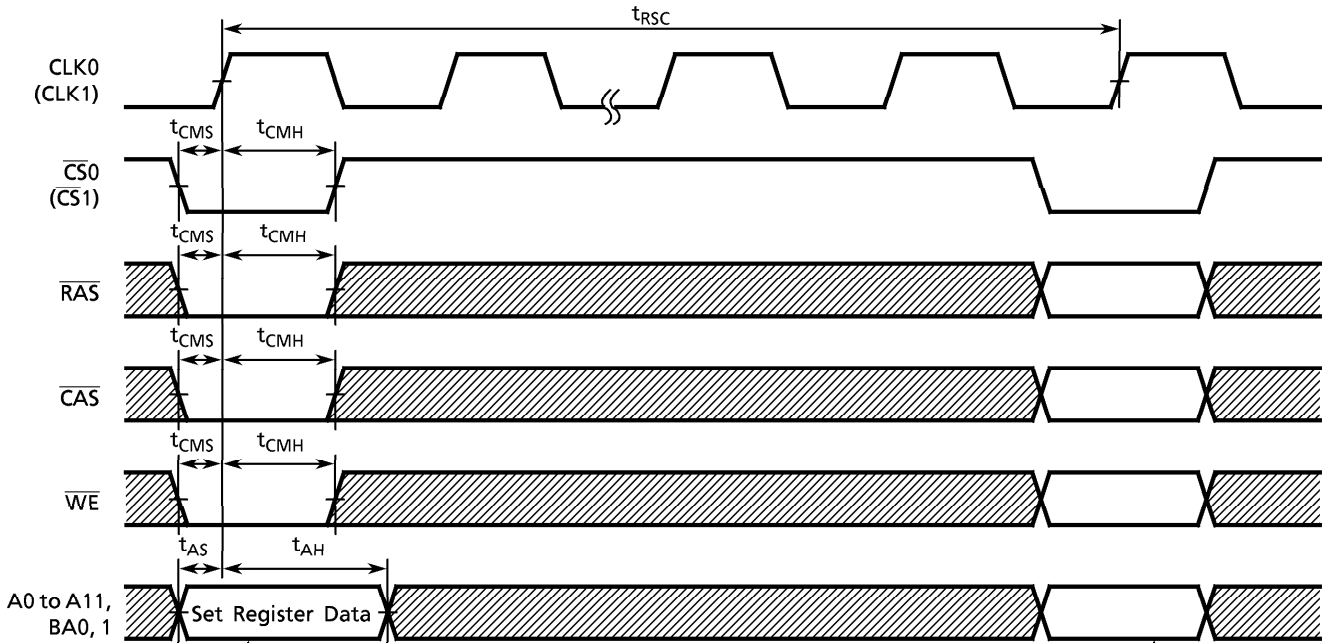

A0	Burst Length	
A1	Burst Length	
A2	Burst Length	
A3	Addressing Mode	
A4	CAS Latency	
A5	CAS Latency	
A6	CAS Latency	
A7	0	(Test Mode)
A8	0	Reserved
A9	Write Mode	
A10	0	Reserved
BA0	0	
BA1	0	

			Burst Length	
A2	A1	A0	Sequential	Interleave
0	0	0	1	1
0	0	1	2	2
0	1	0	4	4
0	1	1	8	8
1	0	0	Reserved	Reserved
1	0	1		
1	1	0	Full Page	Reserved
1	1	1		

A3	Addressing Mode
0	Sequential
1	Interleave

A6	A5	A4	CAS Latency
0	0	0	Reserved
0	0	1	Reserved
0	1	0	2
0	1	1	3
1	0	0	4

A9	Single-Write Mode
0	Burst Read and Burst Write
1	Burst Read and Single Write

Next Command

PACKAGE DIMENSIONS (THLY641681FG)

Unit: mm

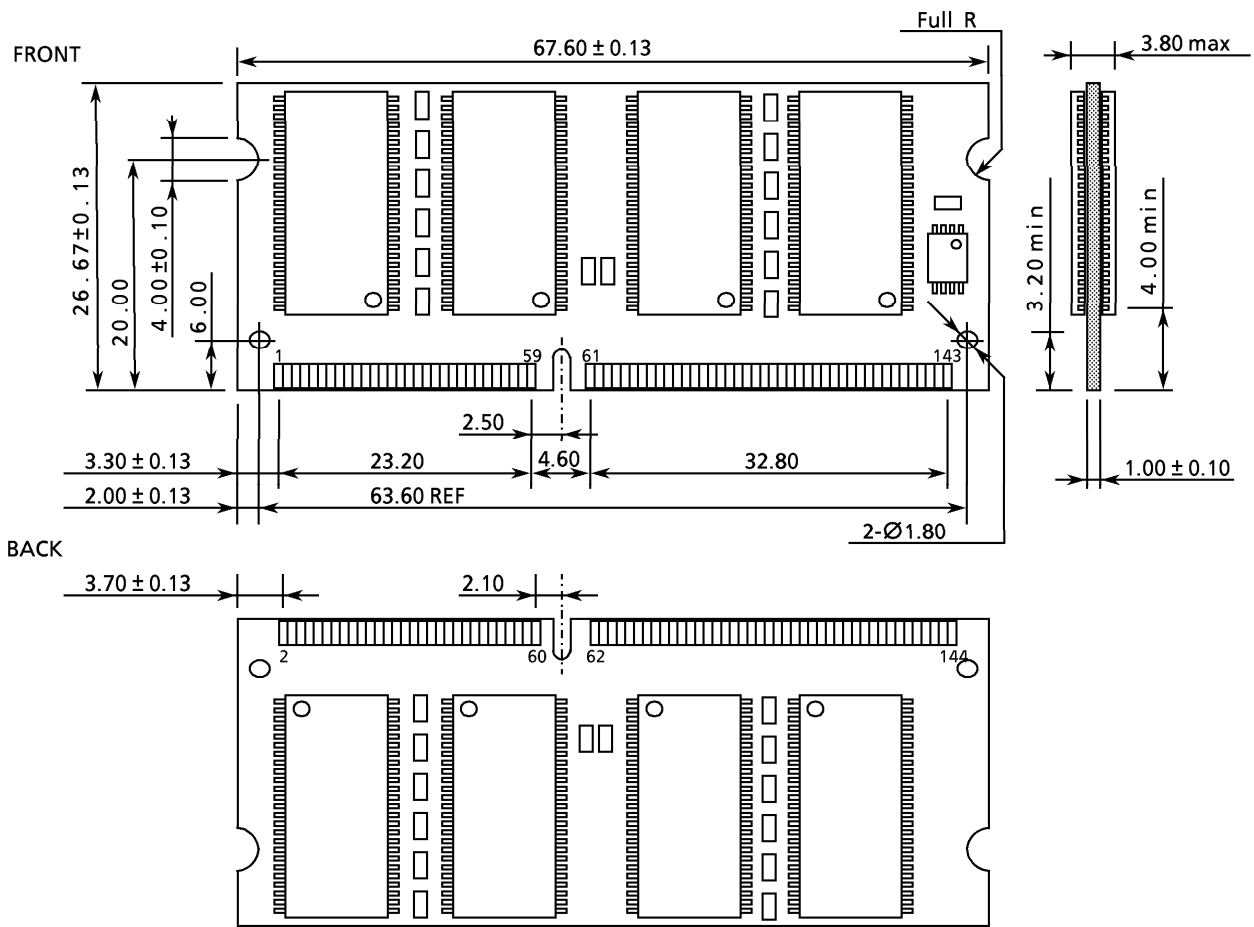

CONTACT DIMENSIONS • THLY641681FG

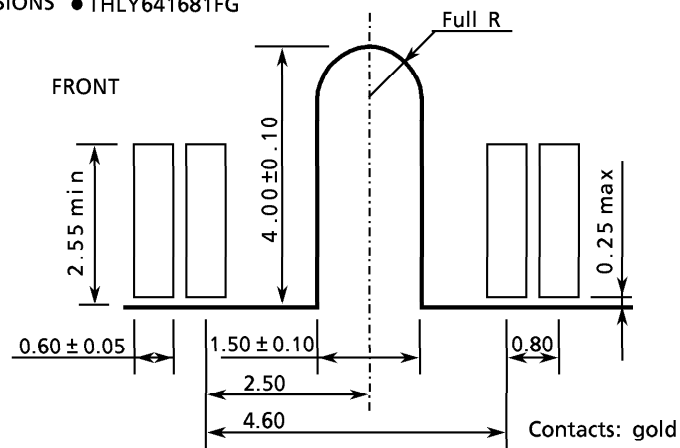

Weight : 8.4g (Typ.)