

PAGE 1/5	ISSUE 13-05-20A	SERIES ANTENNA	PART NUMBER R380845102
----------	-----------------	----------------	------------------------

Scale 7 : 1

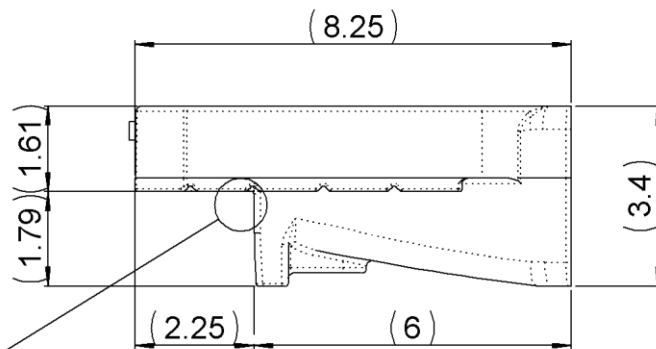

PCB Mounted Scale 20 : 1

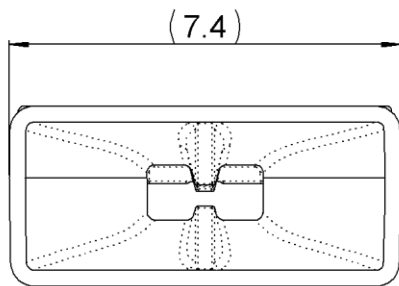
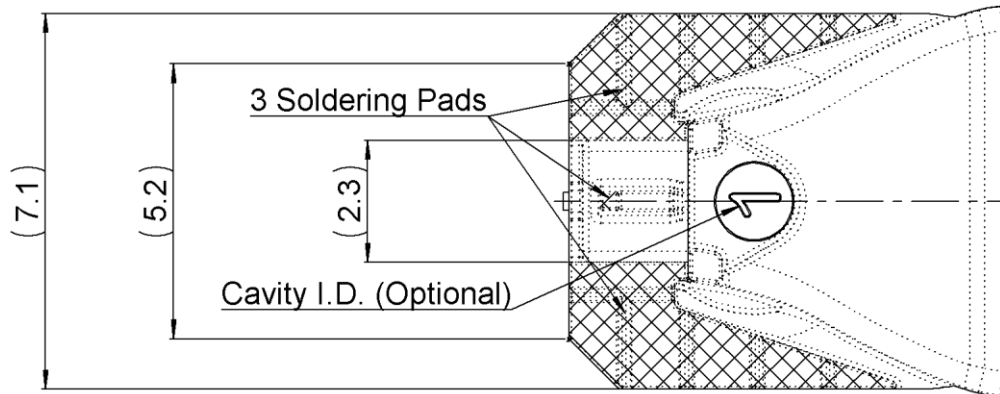
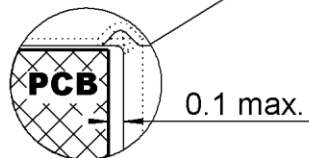

PCB Mounted Scale 5 : 1

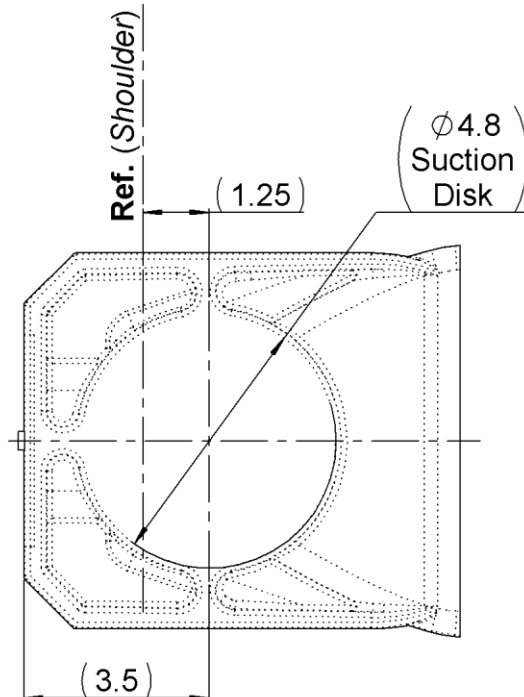
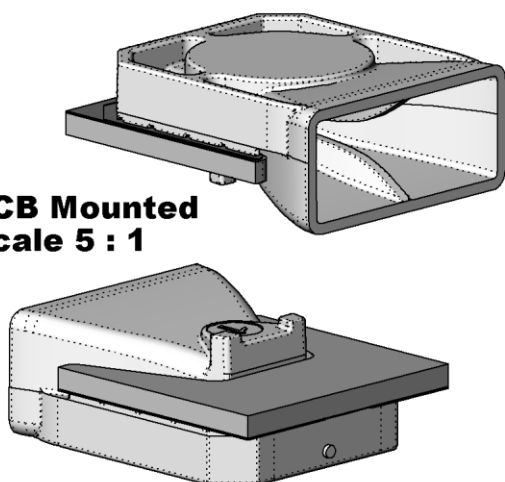

All dimensions are in mm. Tolerances according ISO 2768 m-H

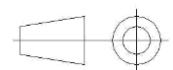

COMPONENTS	MATERIALS	PLATING (μm)
Body	LCP (Liquid Cristal Polymer)	Gold

PAGE 2/5	ISSUE 13-05-20A	SERIES ANTENNA	PART NUMBER R380845102
----------	-----------------	----------------	------------------------

ELECTRICAL CHARACTERISTICS

Frequency Band	57 ~ 66	GHz
Nominal Impedance	50	Ω
Return Loss ⁽¹⁾	< -10	dB (Typ.)
Typical Far-Field Directivity	> 8	dBi
Radiation Pattern	Directional	(Horn)
Polarization	Linear Vertical	
Relative Cross-Polarization Level	> 20	dB
ESD Protection	DC-Ground	

(1): *Measured on Reference Board (See Application Note "201910575-10_..._A_AN.pdf").*

(2): *Tape & Reel Packaging Conditions*

MECHANICAL CHARACTERISTICS

Weight	0.11	g
Overall Dimensions	8.25 x 7.4 x 3.4	mm
Mounting Type	Edge-Card SMT	

ENVIRONMENTAL CHARACTERISTICS

Extreme Storage Temperature ⁽²⁾	-20 / +55	$^{\circ}\text{C}$
Recommended Storage ⁽²⁾	25 \pm 15	$^{\circ}\text{C}$
(12 Months Shelf Life) ⁽²⁾	30 ~ 60	%RH
Reflow Temperature	260	$^{\circ}\text{C Max.}$
Operating Temperature Range	-40 / +85	$^{\circ}\text{C}$
ROHS Compliant	Yes	
REACH Compliant	Yes	

PACKAGING SUFFIX

P/N Suffix	Packaging Type	OD	ID	Order Quantity
20	Large Reel	15"	4"	2000
01	Small Reel	7"	2.4"	100

Other Packaging Available Upon Request

PACKAGING REEL

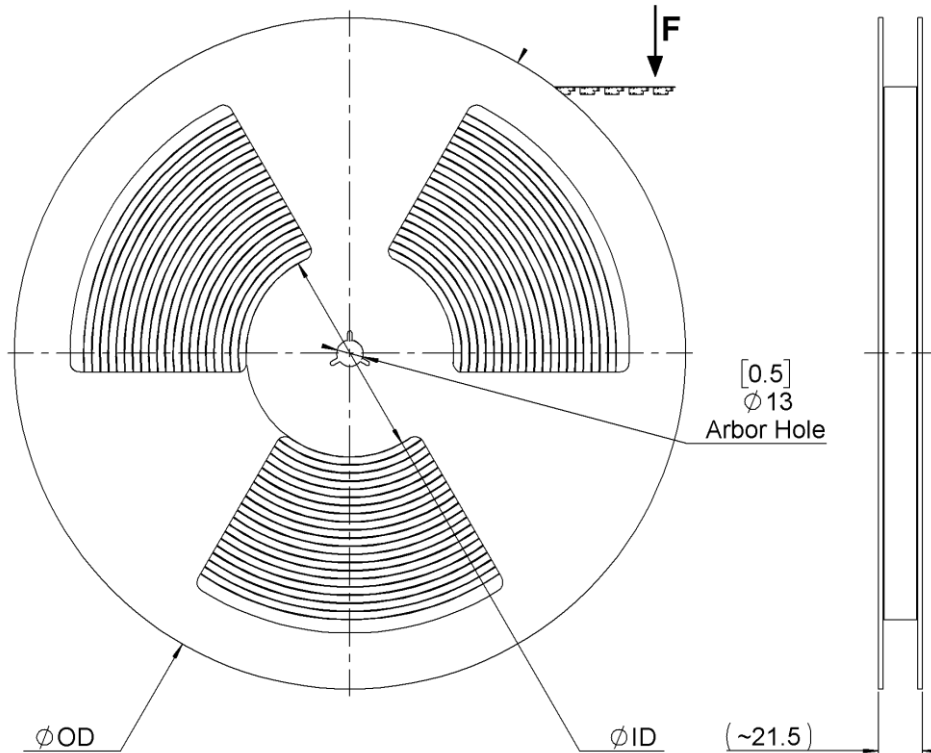

CARRIER TAPE

PAGE 3/5	ISSUE 13-05-20A	SERIES ANTENNA	PART NUMBER R380845102
----------	-----------------	--------------------------	-------------------------------

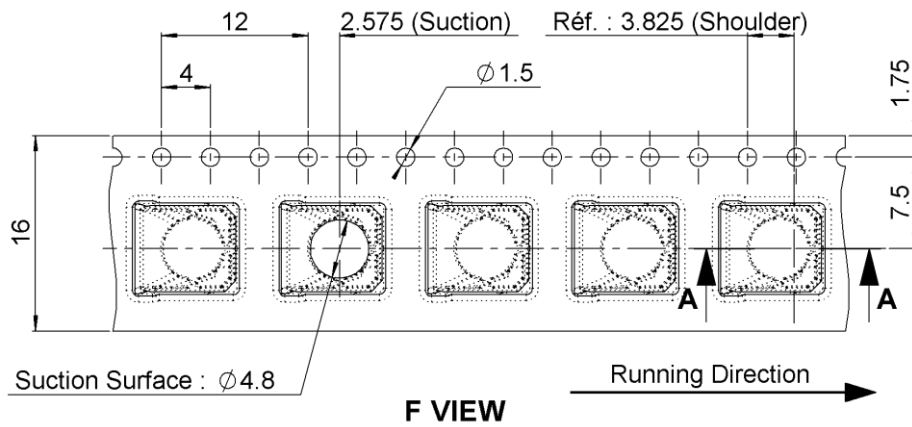
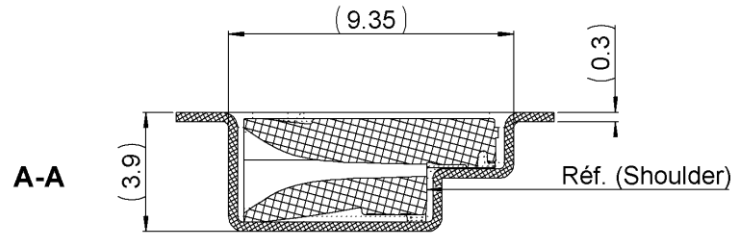

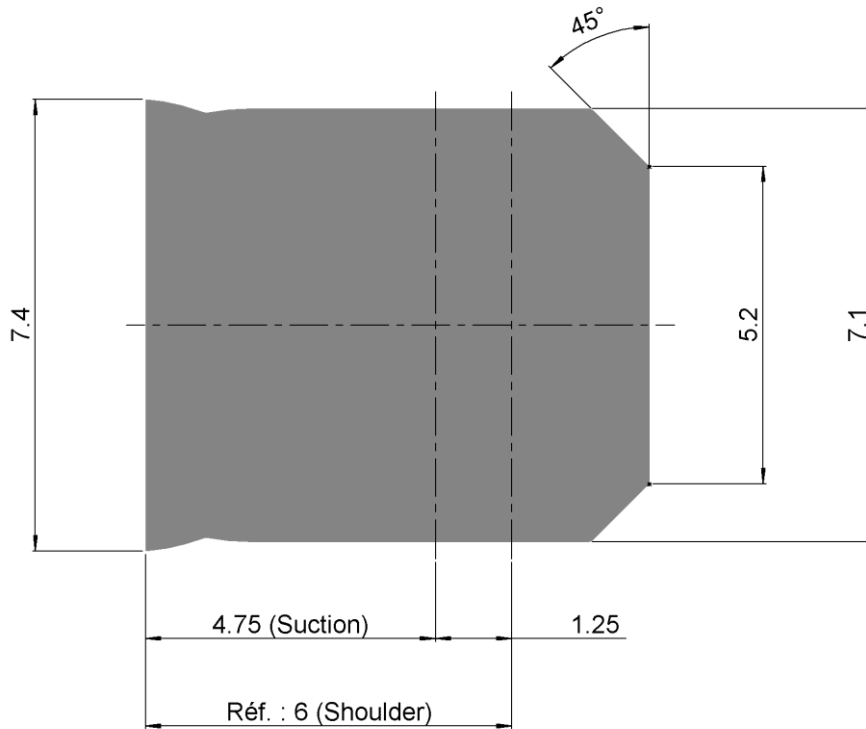

SHADOW FOR VIDEO CAMERA



PAGE 4/5	ISSUE 13-05-20A	SERIES ANTENNA	PART NUMBER R380845102
----------	-----------------	----------------	------------------------

TYPICAL SOLDER MASK & PAD

-  : Solder Mask
-  : Solder Pad
- : Board Outline
- - - - - : Footprint Limit (The PCB can expand beyond it)

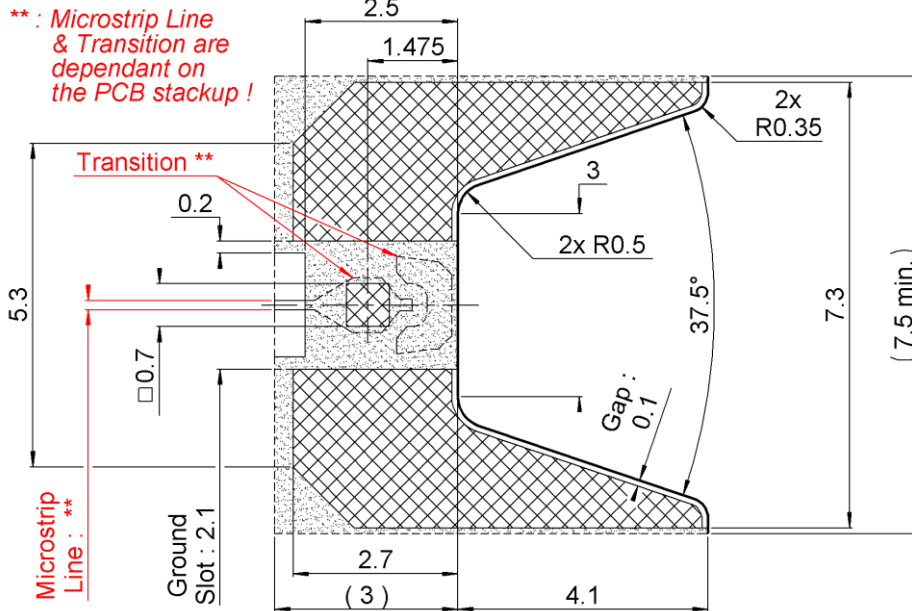

SOLDER PASTE (For 80-100µ Thickness Screens)

-  : Solder Paste
- : Board Outline
- : Screen Limit
- - - - - : Footprint Limit (The PCB can expand beyond it)

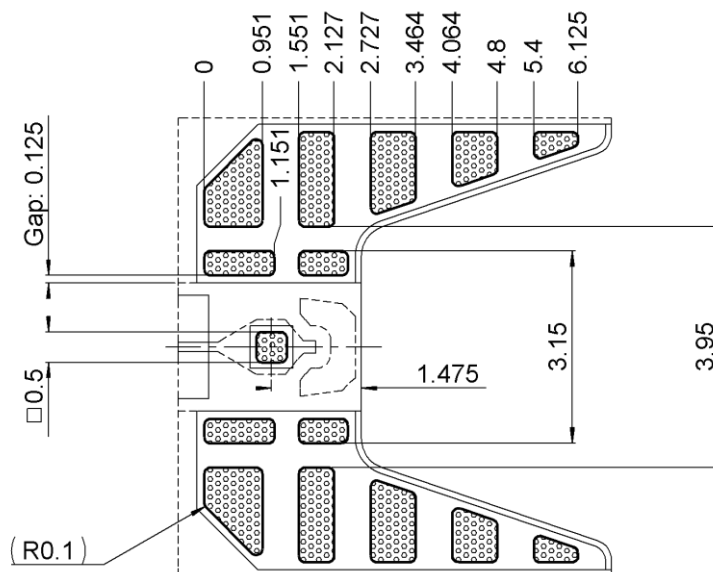

PAGE 5/5	ISSUE 13-05-20A	SERIES ANTENNA	PART NUMBER R380845102
----------	-----------------	--------------------------	-------------------------------

SOLDER PROCEDURE

1. Deposit solder paste 'SnAg4Cu0.5' (T4 or T5) on mounting zone by screen printing application. We recommend a low residue flux. We advise a thickness of 80 to 100 µm (3,150 to 3,940 mils). Verify that the edges of the zone are clean.
2. Placement of the receptacle on the mounting zone with an automatic machine of 'pick and place' type. A video camera is recommended for positioning of the component. Adhesive agents must not be used on the receptacle.
3. This process of soldering has been tested with convection oven .Below please find, the typical profile to use.
4. The cleaning of printed circuit boards is possible, but not mandatory.
5. Verification of solder joints and position of the component by visual inspection (*Component centered on pads, with 100µm max. gap between its shoulder & PCB edge*).

TEMPERATURE PROFILE

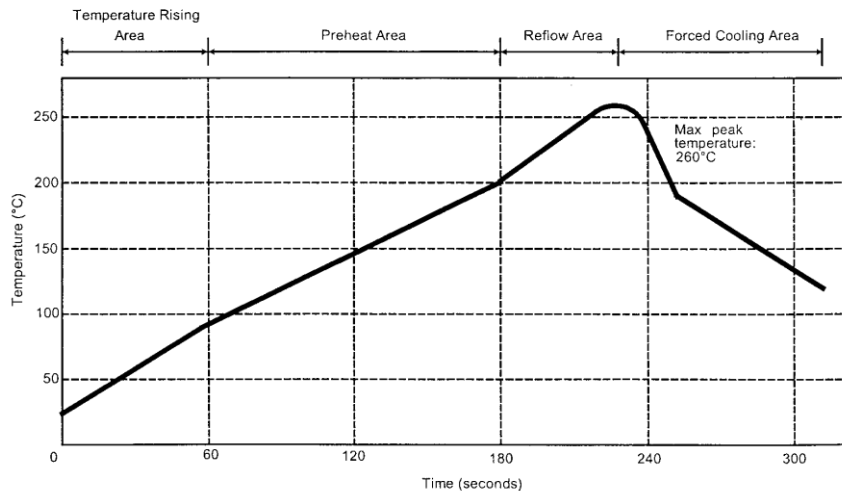

Parameter	Value	Unit
Temperature rising Area	1 - 4	°C/sec
Max Peak Temperature	260	°C
Max dwell time @260°C	10	sec
Min dwell time @235°C	20	sec
Max dwell time @235°C	60	sec
Temperature drop in cooling Area	-1 to - 4	°C/sec
Max dwell time above 100°C	420	sec