



DPE5648

64K X 8 CMOS EEPROM MODULE

7-46-13-27

DESCRIPTION:

The DPE5648 is a high-performance Electrically Erasable and Programmable Read Only Memory (EEPROM) module organized 64K X 8. The DPE5648 is upward pin compatible with the JEDEC standard 128K X 8 EEPROM monolithic and module devices.

The module is built with two low-power CMOS 32K X 8 EEPROMs and one high speed 138 decoder. The decoder uses A15 to select between the two memories.

The DPE5648 contains a 64-Bytes page register to allow writing of up to 64 Bytes simultaneously. During a write cycle, the address and 1 to 64 Bytes of data are internally latched, freeing the address and data bus for other operations. Following the initiation of a write cycle, the module will automatically write the latched data using an internal control timer. The end of a write cycle can be detected by DATA Polling of the most significant data bit. Once the end of a write cycle has been detected, a new access for a read or write can begin.

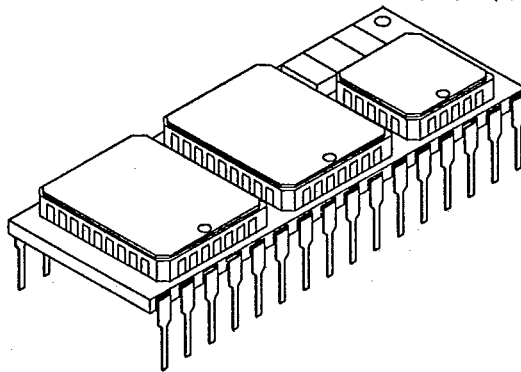

FEATURES:

- Fast Access Times: 90, 120, 150, 170, 200, 250ns
- Automatic Page Write Operation
 - Internal Address and Data Latches
 - Internal Control Timer
- Fast Write Cycle Times
 - Page Write Cycle Time: 10ms maximum
 - 1 to 64 Byte Page Write Operation
- DATA Polling for END of Write Detection
- High Reliability CMOS Technology
 - Endurance: 10⁴ Cycles
 - Data Retention: 10 years

- Pin Compatible with Future 1 and 4 Megabit Monolithic EEPROMs
- Single +5V Power Supply, ±10% Tolerance
- CMOS and TTL Compatible Inputs and Outputs
- Available with All Semiconductor Components used in the Construction of the Module Compliant to MIL-STD-883; Class B
- 32-Pin Ceramic DIP

FUNCTIONAL BLOCK DIAGRAM

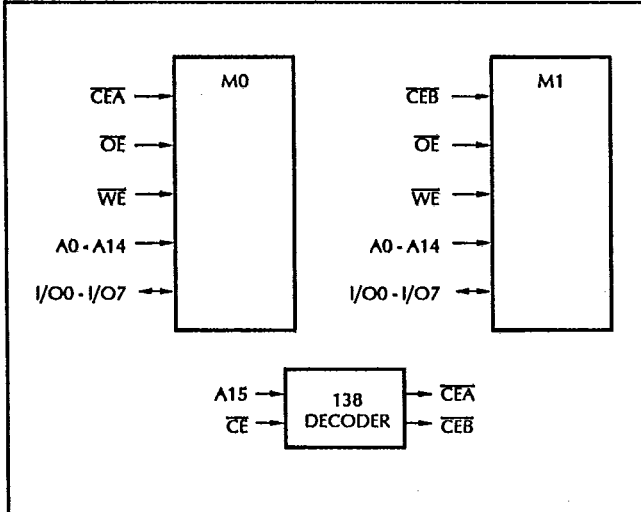

PIN-OUT DIAGRAMS

N.C.	1	32	VDD
*	2	31	WE
A15	3	30	N.C.
A12	4	29	A14
A7	5	28	A13
A6	6	27	A8
A5	7	26	A9
A4	8	25	A11
A3	9	24	OE
A2	10	23	A10
A1	11	22	CE
A0	12	21	I/O7
I/O0	13	20	I/O6
I/O1	14	19	I/O5
I/O2	15	18	I/O4
Vss	16	17	I/O3

* Pin 2 needs to be connected to a logic LOW for proper operation (see Truth Table).

DPE5648

Dense-Pac Microsystems, Inc.

PIN NAMES	
A0 - A15	Address Inputs
I/O0 - I/O7	Data Input/Output
\overline{WE}	Write Enable
\overline{OE}	Output Enable
V _{DD}	Power (+5V)
V _{SS}	Ground
N.C.	No Connect

RECOMMENDED OPERATING RANGE ¹					
Symbol	Characteristic	Min.	Typ.	Max.	Unit
V _{DD}	Supply Voltage	4.5	5.0	5.5	V
V _{IH}	Input HIGH Voltage	2.2		V _{DD} +0.3	V
V _{IL}	Input LOW Voltage	-0.1 ²		0.8	V

ABSOLUTE MAXIMUM RATINGS ³			
Symbol	Parameter	Value	Unit
T _{STC}	Storage Temperature	-65 to + 150	°C
T _{BIAS}	Temperature Under Bias	-55 to + 125	°C
V _{DD}	Supply Voltage ¹	-0.3 to + 6.25	V
V _{I/O}	Input/Output Voltage ¹	-0.3 ² to +6.25	V

TRUTH TABLE					
Mode	Pin 1	\overline{CE}	\overline{OE}	\overline{WE}	I/O Pin
Standby	X	H	X	X	HIGH-Z
Standby	H	X	X	X	HIGH-Z
Read	L	L	L	H	DOUT
Write	L	L	H	L	DIN
Write Inhibit	X	X	L	X	HIGH-Z
Write Inhibit	X	X	X	H	HIGH-Z

L = LOW H = HIGH X = Don't Care

CAPACITANCE ⁴ : T _A = 25°C, F = 1.0MHz				
Symbol	Parameter	Max.	Unit	Condition
C _{CE}	Chip Enable	20	pF	V _{IN} = 0V
C _{ADR}	Address Input	45		
C _{WE}	Write Enable	45		
C _{OE}	Output Enable	45		
C _{I/O}	Data Input/Output	45		

DC OPERATING CHARACTERISTICS: Over the operating ranges.					
Symbol	Characteristics	Test Conditions	LIMITS		Unit
			Min.	Max.	
I _{CC}	Operating Supply Current	$\overline{CE} = \overline{OE} = V_{IL}$, all I/O = 0mA, f = t _{rc} Min.		85	mA
I _{SB1}	V _{DD} Current Standby (TTL)	$\overline{CE} = V_{IH}$		6	mA
I _{SB2}	V _{DD} Current Standby (CMOS)	$\overline{CE} = V_{DD} - 0.3V_{dc}$		0.75	mA
I _{IL}	Input Leakage Current	V _{IN} = V _{DD} Max.	-40	10	μA
I _{OL}	Output Leakage Current	V _{OUT} = V _{DD} Max.	-40	10	μA
V _{IL}	Input Voltage Low		-0.1	0.8	V
V _{IH}	Input Voltage High		2.0	V _{DD} +0.3	V
V _{OL}	Output Voltage Low	I _{OUT} = 2.1mA		0.45	V
V _{OH}	Output Voltage High	I _{OUT} = -400μA	2.4		V

AC TEST CONDITIONS	
Input Pulse Levels	0V to 3.0V
Input Pulse Rise and Fall Times	5ns*
Input and Output Timing Reference Levels	1.5V

* Transition between 0.8V and 2.2V.

OUTPUT LOAD		
Float	C _L	Parameters Measured
1	100 pF	except t _{DF}
2	5 pF	t _{DF}

Figure 1. Output Load

** Including Probe and Jig Capacitance.

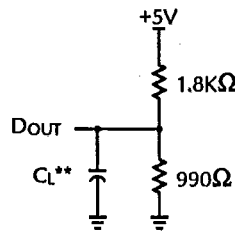

AC OPERATING CONDITIONS AND CHARACTERISTICS - READ CYCLE: Over operating ranges ^{6,7}									
No.	Symbol	Parameter	-90		-120		-150		Unit
			Min.	Max.	Min.	Max.	Min.	Max.	
1	t _{ACC}	Address to Output Valid		90		120		150	ns
2	t _{CE}	Chip Enable to Output Valid		90		120		150	ns
3	t _{OE}	Output Enable to Output Valid		35		45		50	ns
4	t _{DF}	Chip Enable or Output Enable to Output Float ⁴		50		60		65	ns
5	t _{OH}	Output Hold from Chip Enable, Output Enable, or Address, Whichever Occurs First	0		0		0		ns

AC OPERATING CONDITIONS AND CHARACTERISTICS - READ CYCLE: Over operating ranges ^{6,7}									
No.	Symbol	Parameter	-170		-200		-250		Unit
			Min.	Max.	Min.	Max.	Min.	Max.	
1	t _{ACC}	Address to Output Valid		170		200		250	ns
2	t _{CE}	Chip Enable to Output Valid		170		200		250	ns
3	t _{OE}	Output Enable to Output Valid		70		75		80	ns
4	t _{DF}	Chip Enable or Output Enable to Output Float ⁴		70		70		75	ns
5	t _{OH}	Output Hold from Chip Enable, Output Enable, or Address, Whichever Occurs First	0		0		0		ns

AC OPERATING CONDITIONS AND CHARACTERISTICS - WRITE CYCLE: Over operating ranges ^{6,7}					
No.	Symbol	Parameter	MIN.	MAX.	Unit
6	t _{WC}	Write Cycle Time		10	ms
7	t _{AS}	Address Set-up Time***	20		ns
8	t _{AH}	Address Hold Time	100		ns
9	t _{CS}	Chip Select Set-up Time	0		ns
10	t _{CH}	Chip Select Hold Time	0		ns
11	t _{WP}	Write Pulse Width (CE or OE)	150		ns
12	t _{DS}	Data Set-up Time	100		ns
13	t _{DH}	Data Hold Time	10		ns
14	t _{OES}	CE Hold Time	20		ns
15	t _{OEH}	OE Hold Time	20		ns
16	t _{WPH}	Write Pulse Width High	100		ns
17	t _{BLC}	Byte Load Cycle Time		150	μs

*** Valid for both Read and Write Cycles.

DPE5648

Dense-Pac Microsystems, Inc.

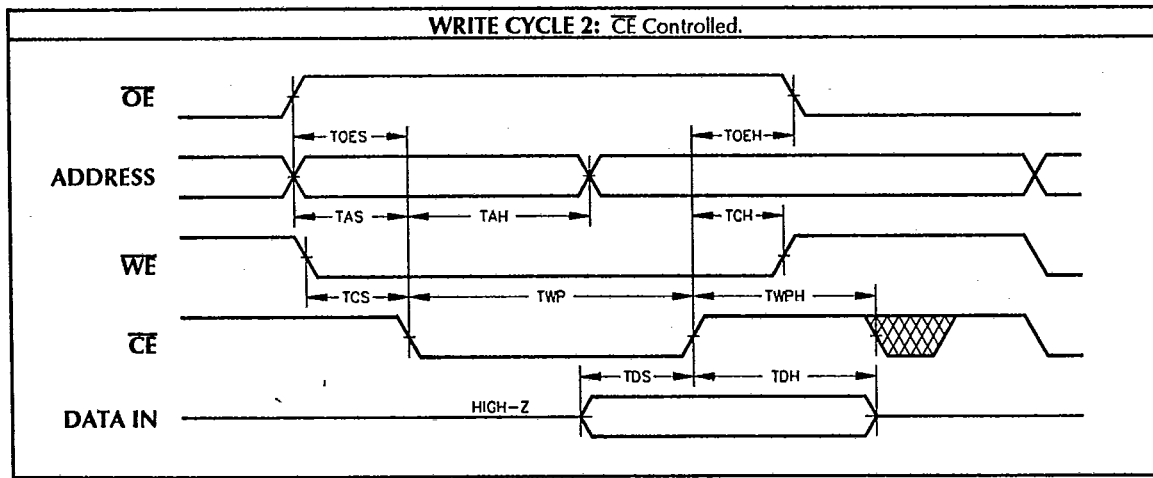
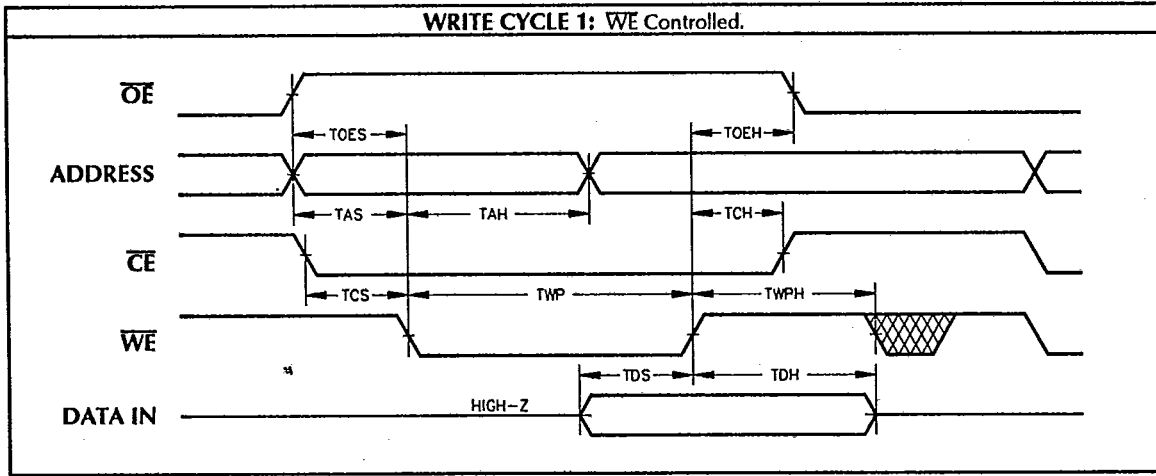
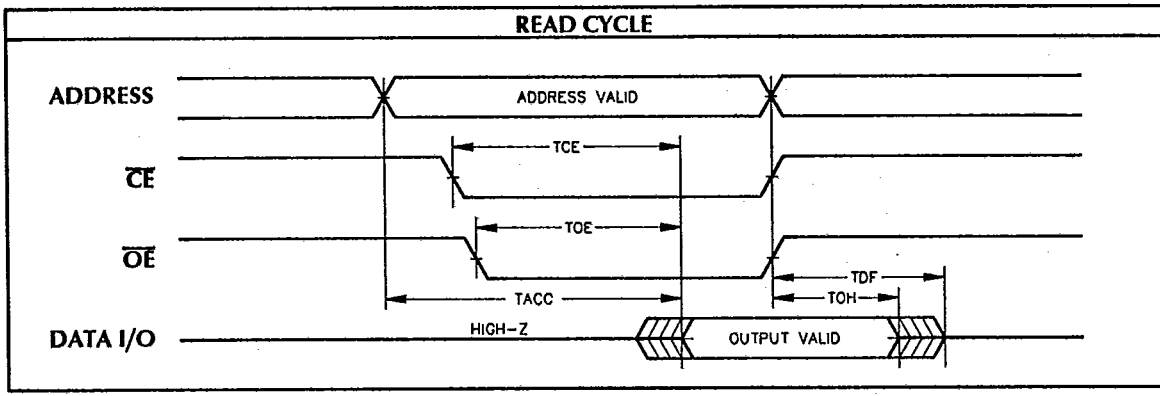

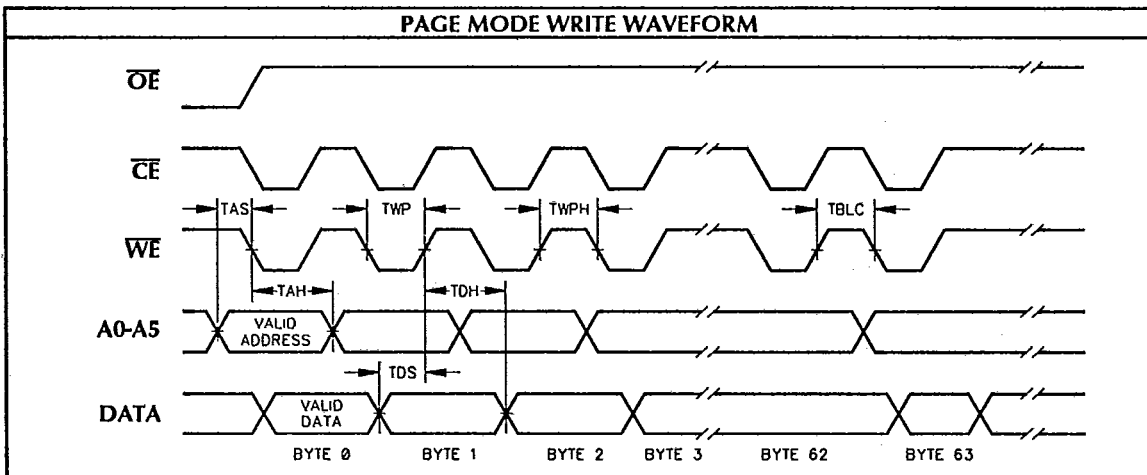

5

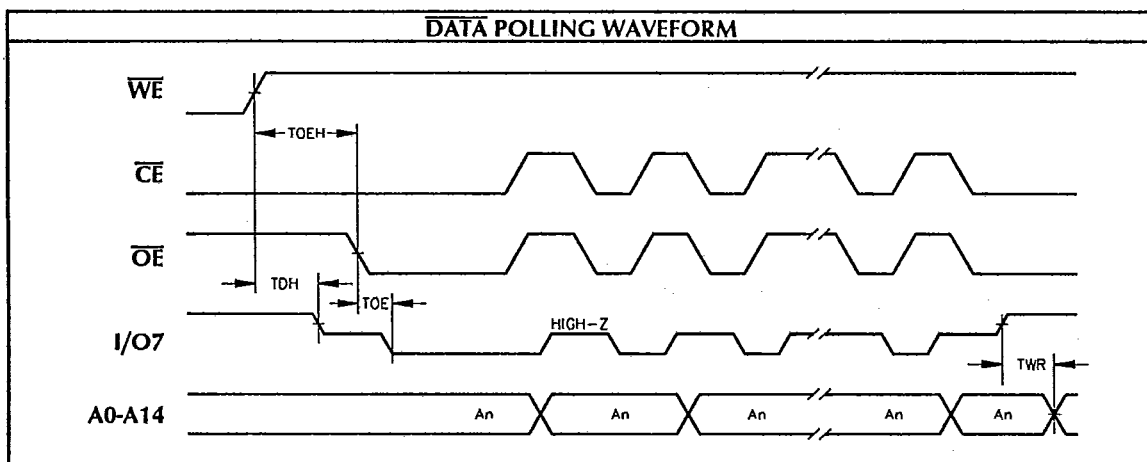

DEVICE OPERATION

READ: The DPE5648 is accessed like a Static RAM. When \overline{CE} and \overline{OE} are low and \overline{WE} is high, the data stored at the memory location determined by address pins is asserted on the outputs. The outputs are put in the high impedance state whenever \overline{CE} or \overline{OE} is high. This dual line control gives designers flexibility in preventing bus contention.

WRITE: A low pulse on the \overline{WE} or \overline{CE} input with \overline{CE} or \overline{WE} low (respectively) and \overline{OE} high initiates a write cycle. The address is latched on the falling edge of \overline{CE} or \overline{WE} , whichever occurs last. The data is latched by the first rising edge of \overline{CE} or \overline{WE} . Once a Byte write has been started it will automatically time itself to completion.

PAGE WRITE MODE: The page write operation of the DPE5648 allows 1 to 64 Bytes of data to be loaded into the device and then simultaneously written during the internal programming period. After the first data Byte has been loaded into the device, successive Bytes may be loaded in the same manner. Each new Byte to be written must have its high to low transition on \overline{WE} (or \overline{CE}) within 150 μ s of the low

to high transition of \overline{WE} (or \overline{CE}) of the preceding Byte. If a high to low transition is not detected within 150 μ s of the last low to high transition, the load period will end and the internal programming period will start. $A6$ to $A15$ specify the page address. The page address must be valid during each high to low transition of \overline{WE} (or \overline{CE}). $A0$ to $A5$ are used to specify which Bytes within the page are to be written. The Bytes may be loaded in any order and may be changed within the same load period. Only Bytes which are specified for writing will be written; unnecessary cycling of other Bytes within the page does not occur.

DATA POLLING: The DPE5648 features \overline{DATA} Polling to indicate the end of a write cycle. During a byte or page write cycle an attempted read of the last byte written will result in the compliment of the written data on $I/O7$. Once the the write cycle has been completed, true data is valid on all outputs, and the next cycle may begin. \overline{DATA} Polling may begin at any time during the write cycle.

DPE5648

Dense-Pac Microsystems, Inc.

ORDERING INFORMATION			
DP	E5648	- XXX	X
<u>PREFIX</u>	<u>DEVICE TYPE</u>	<u>SPEED</u>	<u>GRADE</u>
			C COMMERCIAL 0°C to +70°C I INDUSTRIAL -40°C to +85°C M MILITARY -55°C to +125°C B* MIL-PROCESSED -55°C to +125°C
			90 90ns 120 120ns 150 150ns 170 170ns 200 200ns 250 250ns
			64K X 8 CMOS EEPROM MODULE

* B grade modules built with 883 devices.

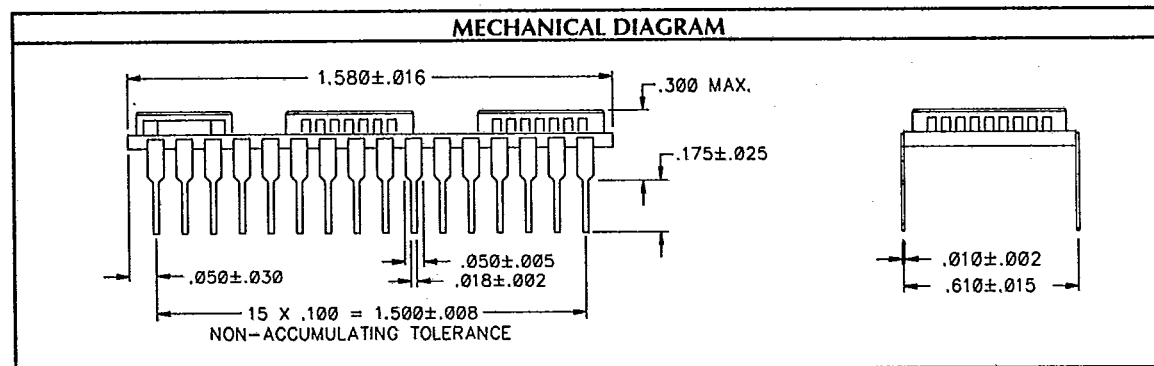

NOTES:

1. All voltages are with respect to V_{SS}.
2. -1.0V min. for pulse width less than 20ns (V_{IL} min. = -0.3V at DC level).
3. Stresses greater than those under **ABSOLUTE MAXIMUM RATINGS** may cause permanent damage to the device. This is a stress rating only and functional operation of the device at these or any other conditions above those indicated in the operational sections of this specification is not implied. Exposure to absolute maximum rating conditions for extended periods may affect reliability.
4. This parameter is guaranteed and not 100% tested.
5. Transition is measured at the point of ±500mV from steady state voltage.
6. When \overline{OE} and \overline{CE} are LOW and \overline{WE} is HIGH, I/O pins are in the output state; and input signals of opposite phase to the outputs must not be applied.
7. The outputs are in a high impedance state when \overline{WE} is LOW.

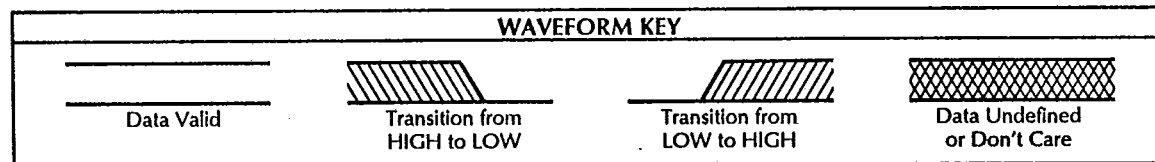

Dense-Pac Microsystems, Inc.

7321 Lincoln Way • Garden Grove, California 92641-1428
 (714) 898-0007 • (800) 642-4477 (Outside CA) • FAX: (714) 897-1772