

50 Ω

DC – 4 GHz

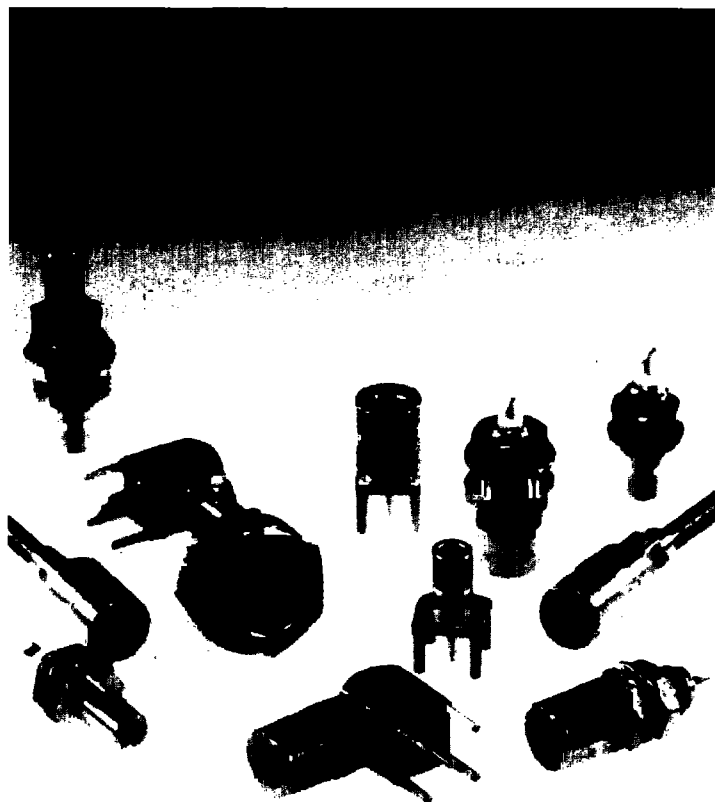

## GENERAL

- Subminiature coaxial connectors
- Snap-on coupling
- Low weight
- Reduced outline dimensions

V

## APPLICABLE STANDARDS

- SMB series MIL-C-39012
- BS 9210 N 0007
- CECC 22130
- IEC 169-10

## QUALIFICATIONS / APPROVALS

- QPL
- CECC (pending)



## CONTENTS

General .....	V 3
Characteristics .....	V 4
Interface .....	V 5
Plugs & Jacks .....	V 6-9
Receptacles .....	V 10-11
In series adapters .....	V 12-13
SMB-A receptacles .....	V 14
SUBGLIS receptacles .....	V 15
Mounting instructions .....	V 16-24

## APPLICATIONS

- Video
- IF Systems
- Civil & Military Telecommunication
- Aeronautics
- Missiles
- Mobile communication systems

## CHARACTERISTICS

REQUIREMENT	MIL - C - 39012 paragraph	GENERAL SPECIFICATIONS									
<b>ELECTRICAL</b>											
Impedance		50 $\Omega$									
Frequency range		0 - 4 GHz									
V.S.W.R.	3 - 14	<table border="0"> <tr> <td>cable</td> <td>2/50</td> <td>2,6/50</td> </tr> <tr> <td>straight</td> <td>1,30 +0,04 F (GHz)</td> <td>1,25 +0,04 F (GHz)</td> </tr> <tr> <td>right angle</td> <td>1,45 +0,06 F (GHz)</td> <td>1,35 +0,04 F (GHz)</td> </tr> </table>	cable	2/50	2,6/50	straight	1,30 +0,04 F (GHz)	1,25 +0,04 F (GHz)	right angle	1,45 +0,06 F (GHz)	1,35 +0,04 F (GHz)
cable	2/50	2,6/50									
straight	1,30 +0,04 F (GHz)	1,25 +0,04 F (GHz)									
right angle	1,45 +0,06 F (GHz)	1,35 +0,04 F (GHz)									
Insertion loss	3 - 27	<table border="0"> <tr> <td>straight</td> <td>: 0,3 dB max. at 1,5 GHz</td> </tr> <tr> <td>right angle</td> <td>: 0,6 dB max. at 1,5 GHz</td> </tr> </table>	straight	: 0,3 dB max. at 1,5 GHz	right angle	: 0,6 dB max. at 1,5 GHz					
straight	: 0,3 dB max. at 1,5 GHz										
right angle	: 0,6 dB max. at 1,5 GHz										
RF leakage	3 - 26	- 55 dB min. between 2 and 3 GHz									
Insulation resistance	3 - 11	1000 megohms min.									
Contact resistance	3 - 16	<table border="1"> <thead> <tr> <th></th> <th>Initial</th> <th>After environment</th> </tr> </thead> <tbody> <tr> <td>Centre contact (m<math>\Omega</math>)</td> <td>6</td> <td>8</td> </tr> <tr> <td>Outer contact (m<math>\Omega</math>)</td> <td>1</td> <td>1,5</td> </tr> </tbody> </table>		Initial	After environment	Centre contact (m $\Omega$ )	6	8	Outer contact (m $\Omega$ )	1	1,5
	Initial	After environment									
Centre contact (m $\Omega$ )	6	8									
Outer contact (m $\Omega$ )	1	1,5									
Voltage rating (volts RMS)		<table border="0"> <tr> <td>cable 2/50</td> <td>: at sea level 250 V, at 70000 ft</td> <td>60 V</td> </tr> <tr> <td>cable 2,6/50</td> <td>: at sea level 335 V, at 21000 m</td> <td>85 V</td> </tr> </table>	cable 2/50	: at sea level 250 V, at 70000 ft	60 V	cable 2,6/50	: at sea level 335 V, at 21000 m	85 V			
cable 2/50	: at sea level 250 V, at 70000 ft	60 V									
cable 2,6/50	: at sea level 335 V, at 21000 m	85 V									
Dielectric withstanding voltage	3 - 17	<table border="0"> <tr> <td>cable 2/50</td> <td>: at sea level 750 V, at 70000 ft</td> <td>185 V</td> </tr> <tr> <td>cable 2,6/50</td> <td>: at sea level 1000 V, at 21000 m</td> <td>250 V</td> </tr> </table>	cable 2/50	: at sea level 750 V, at 70000 ft	185 V	cable 2,6/50	: at sea level 1000 V, at 21000 m	250 V			
cable 2/50	: at sea level 750 V, at 70000 ft	185 V									
cable 2,6/50	: at sea level 1000 V, at 21000 m	250 V									
RF high potential withstanding voltage (Frequency 5 MHz)	3 - 23	<table border="0"> <tr> <td>cable 2/50</td> <td>: at sea level</td> <td>500 V</td> </tr> <tr> <td>cable 2,6/50</td> <td>: at sea level</td> <td>700 V</td> </tr> </table>	cable 2/50	: at sea level	500 V	cable 2,6/50	: at sea level	700 V			
cable 2/50	: at sea level	500 V									
cable 2,6/50	: at sea level	700 V									
<b>MECHANICAL</b>											
Life	3 - 15	500 matings									
Force to engage and disengage	3 - 5 - 1	14 Lbs max. - 62 N max. 9 N mini.									
Mating torque		Not applicable									
Coupling nut proof torque		Not applicable									
Coupling nut retention force	3 - 25	Not applicable									
Cable retention force	3 - 24	cable 2/50 : 13 Lbs - 58 N. and cable 2,6/50 : 25 Lbs - 110 N.									
Contact captivation		axial force : 4 Lbs - 15 N ; torque : not applicable.									
<b>ENVIRONMENTAL</b>											
Operating temperature range		<table border="0"> <tr> <td>standard models</td> <td>: - 65°C + 165°C</td> </tr> <tr> <td>hermetic</td> <td>: - 65°C + 165°C</td> </tr> <tr> <td>semi rigid cables</td> <td>: - 65°C + 105°C</td> </tr> </table>	standard models	: - 65°C + 165°C	hermetic	: - 65°C + 165°C	semi rigid cables	: - 65°C + 105°C			
standard models	: - 65°C + 165°C										
hermetic	: - 65°C + 165°C										
semi rigid cables	: - 65°C + 105°C										
Temperature cycling		MIL - STD - 202, method 102, condition C									
Thermal shock	3 - 20	MIL - STD - 202, method 107, condition B									
High temperature test		MIL - STD - 202, method 108									
Corrosion (salt spray)	3 - 13	MIL - STD - 202, method 101, condition B, 5%									
Vibration	3 - 18	MIL - STD - 202, method 204, condition B, 15 g									
Shock	3 - 19	MIL - STD - 202, method 213, condition B, 75 g									
Moisture resistance	3 - 21	not applicable									
Barometric pressure	3 - 22	MIL - STD - 202, method 105, condition C									
Hermetic test		down to 10 <sup>-6</sup> mm Hg (Torr) leak rate 1 x 10 <sup>-6</sup> atm/cm <sup>3</sup> /sec									
<b>MATERIALS</b>											
Bodies and male contacts		brass, half hard per QQ - B - 626									
Female contacts and interfaces		beryllium copper per QQ - C - 530									
Ferrules		brass									
Insulators		PTFE teflon									
Gaskets		silicone rubber									
<b>PLATING</b>											
Body		gold to satisfy the corrosion requirements									
Center contacts		gold									

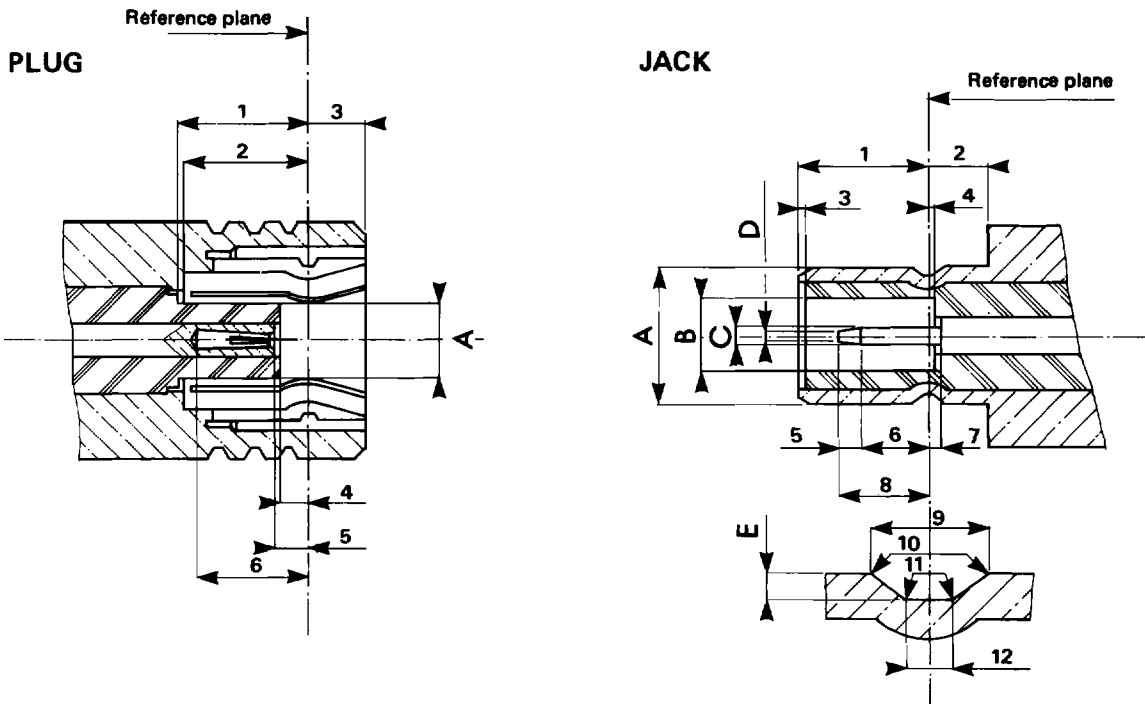

V

REP.	mm PLUG inch.			
	min.	max.	min.	max.
1	3,58	—	.141	—
2	3,58	—	.141	—
3	—	1,63	—	.064
4	0,18	—	.007	—
5	0,18	0,94	.007	.037
6	2,97	—	.117	—
Ø A	—	2,06	—	.081

REP.	mm JACK inch.			
	min.	max.	min.	max.
1	3,33	3,58	.131	.141
2	1,65	—	.065	—
3	000	—	.000	—
4	—	0,18	—	.007
5	0,25	—	.010	—
6	1,32	—	.052	—
7	—	0,18	—	.007
8	—	2,97	—	.117
9	0,69	0,94	.027	.037
10	0,05	0,15	.002	.006
11	—	0,13	—	.005
12	0,28	0,38	.011	.015
Ø A	—	3,71	—	.146
Ø B	2,08	—	.082	—
Ø C	0,48	0,53	.019	.021
Ø D	—	0,25	—	.010
E	0,15	0,25	.006	.010

# SMB

## FOR FLEXIBLE CABLE, CABLE CLAMP TYPE

### STRAIGHT PLUG

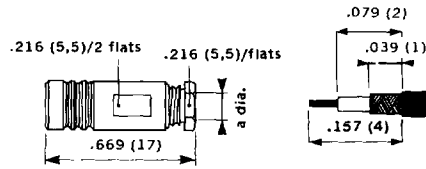
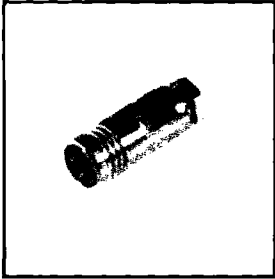

CABLE RG	178 B/U - 196 A/U	174 A/U - 188 A/U 179 B/U - 187 A/U
PART NUMBER	<b>R 114 003 133</b>	<b>R 114 005 133</b>
MIL no.	UG - 1451/U M 39012/67-0003	UG - 1456/U M 39012/67-0004
a dia.	.087 (2,2)	.118 (3)
Assembly	M 01	M 01

### RIGHT ANGLE PLUG

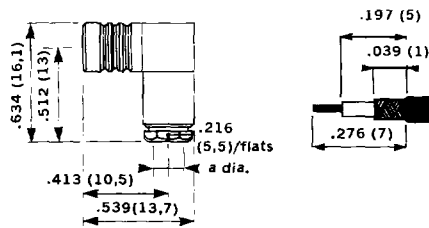
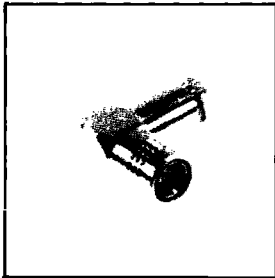

CABLE RG	178 B/U - 196 A/U	174 A/U - 188 A/U 179 B/U - 187 A/U
PART NUMBER	<b>R 114 163 133</b>	<b>R 114 165 133</b>
MIL no.	UG - 1452/U M 39012/69 - 0003	UG - 1457/U M 39012/69 - 0004
a dia.	.087 (2,2)	.118 (3)
Assembly	M 02	M 02

### STRAIGHT JACK

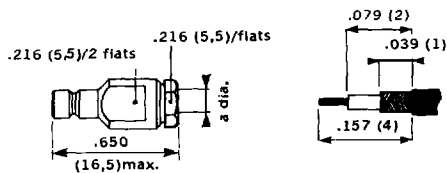
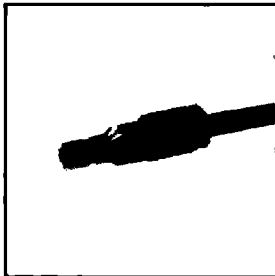

CABLE RG	178 B/U - 196 A/U	174 A/U - 188 A/U 179 B/U - 187 A/U
PART NUMBER	<b>R 114 203 133</b>	<b>R 114 205 133</b>
MIL no.	M 39012/68 - 0003	M 39012/68 - 0004
a dia.	.087 (2,2)	.118 (3)
Assembly	M 01	M 01

### BULKHEAD JACK

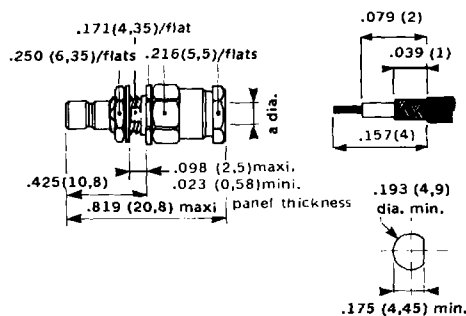
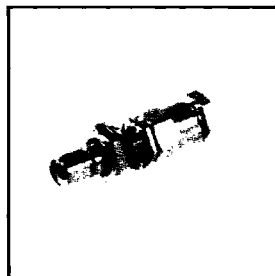

CABLE RG	178 B/U - 196 A/U	174 A/U - 188 A/U 179 B/U - 187 A/U
PART NUMBER	<b>R 114 303 133</b>	<b>R 114 305 133</b>
MIL no.	UG - 1454/U M 39012/70 - 0003	UG - 1459/U M 39012/70 - 0004
a dia.	.087 (2,2)	.118 (3)
Assembly	M 01	M 01

CABLE RG	174 A/U - 188 A/U * 179 B/U - 187 A/U
PART NUMBER	<b>R 114 082</b>
MIL no.	M 39012/67 - 0006 *
Assembly	M 07

\* MIL standed part superseded

★ Model for double screen cable : **R 114 083**

### STRAIGHT PLUG (full crimp)

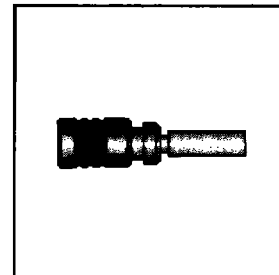
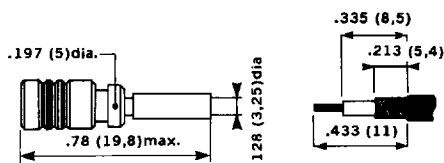

CABLE RG	178 B/U - 196 A/U	174 A/U - 188 A/U 179 B/U - 187 A/U
PART NUMBER	<b>R 114 073 134</b>	<b>R 114 075 134</b>
MIL no.	M 39012/67 - 0008	M 39012/67-0010 M 39012/67-0009
a dia.	.098 (2,5)	.126 (3,2)
Assembly	M 05	M 05

★ Model for RD316 cable : **R 114 075 120**

### STRAIGHT PLUG

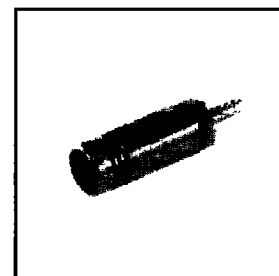
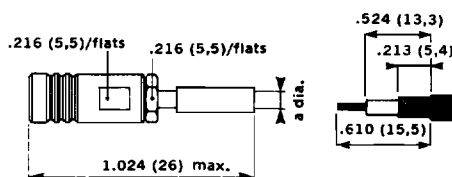

CABLE RG	178 B/U - 196 A/U	174 A/U - 188 A/U 179 B/U - 187 A/U
PART NUMBER	<b>R 114 183</b>	<b>R 114 186</b>
MIL no.	M 39012/69 - 0008	M 39012/69-0010 M 39012/69-0009
a dia.	.098 (2,5)	.126 (3,2)
Assembly	M 06	M 06

### RIGHT ANGLE PLUG

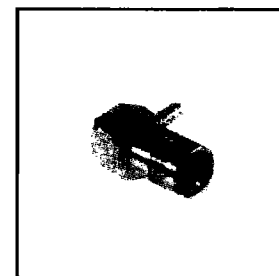
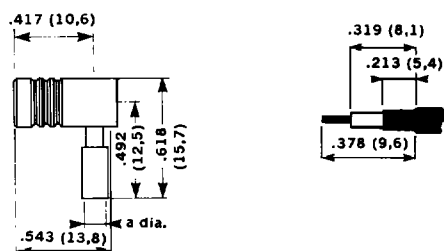

CABLE RG	174 A/U - 188 A/U 179 B/U - 187 A/U
PART NUMBER	<b>R 114 187</b>
Assembly	M 09

### RIGHT ANGLE PLUG

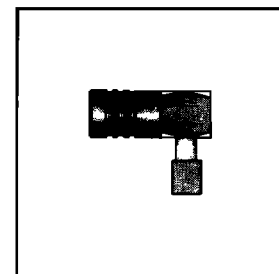
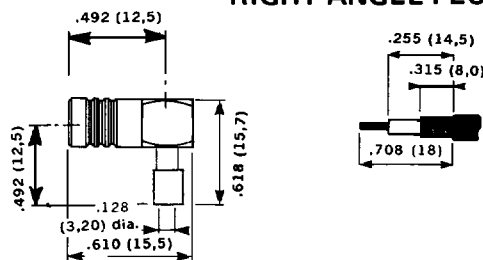

# SMB

## FOR FLEXIBLE CABLE, CRIMP TYPE

### STRAIGHT JACK

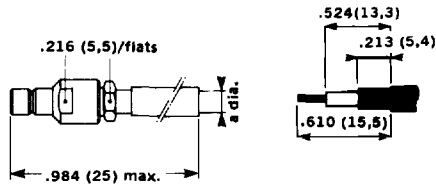
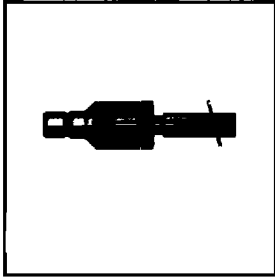

CABLE RG	178 B/U - 196 A/U	174 A/U - 188 A/U 179 B/U - 187 A/U
PART NUMBER	R 114 237	R 114 239
MIL no.	M 39012/68 - 0008	M 39012/68-0010 M 39012/68-0009
a dia.	.098 (2,5)	.126 (3,2)
Assembly	M 05	M 05

### BULKHEAD JACK

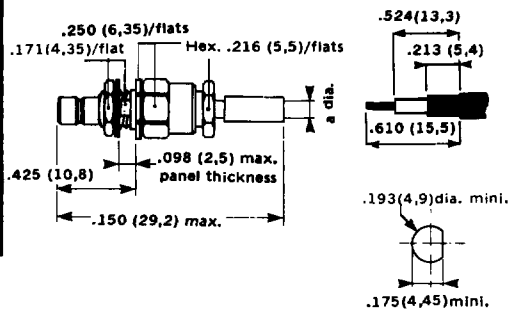
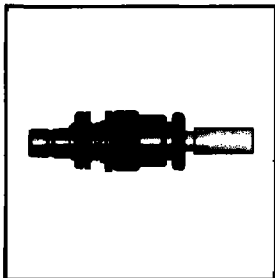

CABLE RG	178 B/U - 196 A/U	174 A/U - 188 A/U 179 B/U - 187 A/U
PART NUMBER	R 114 311	R 114 312
MIL no.	M 39012/70008	M 39012/700009 M 39012/700010
a dia.	.098 (2,5)	.126 (3,2)
Assembly	M 05	M 05

### STRAIGHT JACK

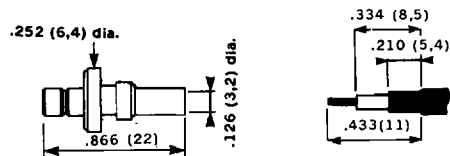
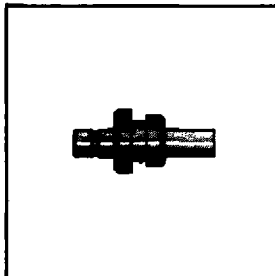

CABLE RG	174 A/U - 188 A/U 179 B/U - 187 A/U
PART NUMBER	R 114 238
Assembly	M 07

### BULKHEAD JACK

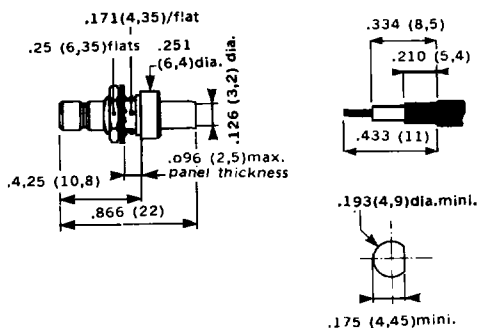
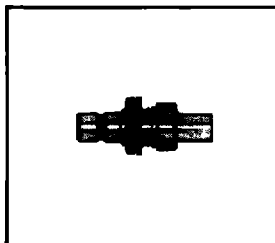

CABLE RG	174 A/U - 188 A/U 179 B/U - 187 A/U
PART NUMBER	R 114 313
Assembly	M 07

### STRAIGHT PLUG

CABLE Ø	.085"
PART NUMBER	R 114 053
Assembly	M 03

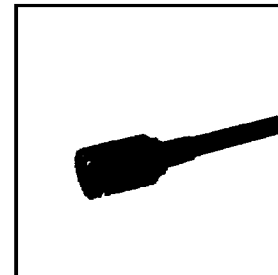
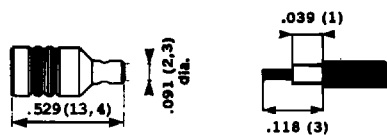

V

### RIGHT ANGLE PLUG

CABLE Ø	.085"
PART NUMBER	R 114 169
Assembly	M 04

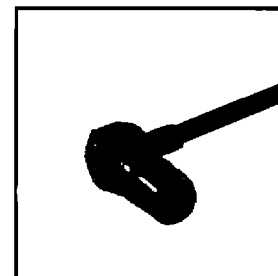
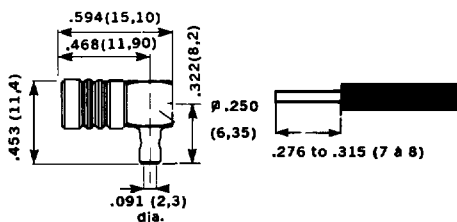

### BULKHEAD JACK

CABLE Ø	.085"
PART NUMBER	R 114 222
Assembly	M 08

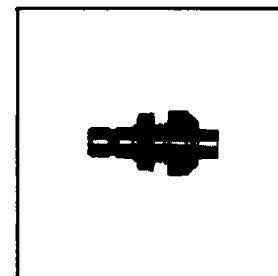
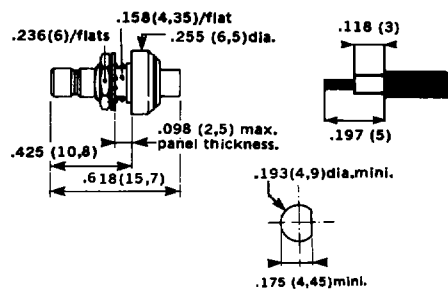

# SMB

## FLANGE AND BULKHEAD RECEPTACLES

### BULKHEAD RECEPTACLE REAR NUT FIXING

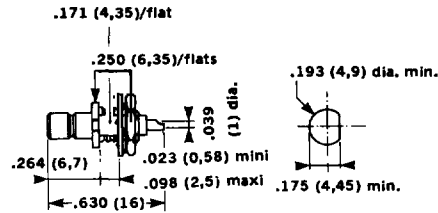
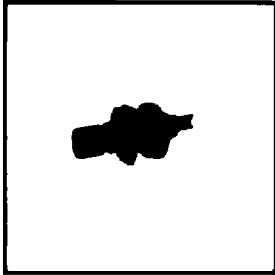

PART NUMBER

R 114 553

MIL no.

M 39012/71 - 0002

### BULKHEAD RECEPTACLE FRONT NUT FIXING

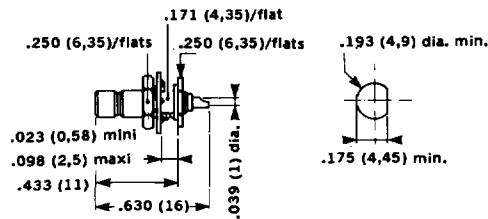
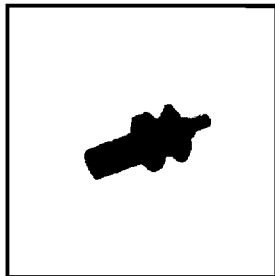

PART NUMBER

R 114 554

MIL no.

UG - 1455/U  
M 39012/71 - 0001

### RECESSED BULKHEAD RECEPTACLE

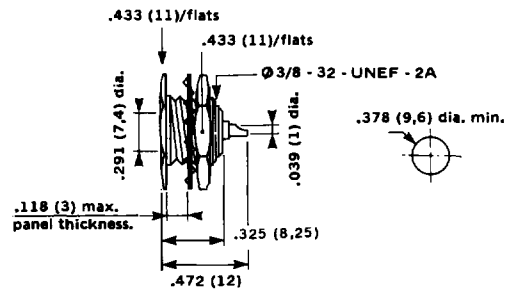
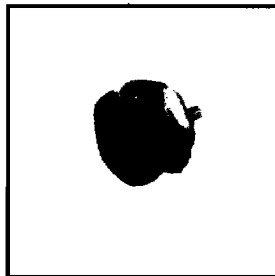

PART NUMBER

R 114 566

### HERMETICALLY SEALED BULKHEAD RECEPTACLE FRONT NUT FIXING

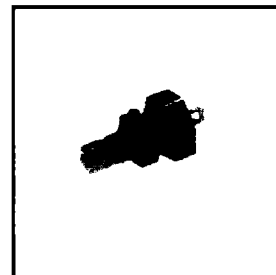
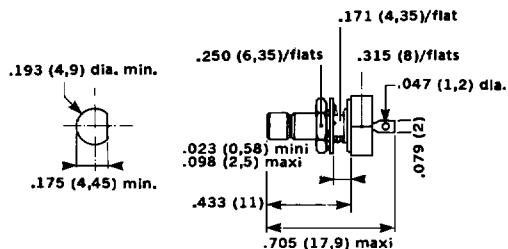

PART NUMBER	R 114 603
MIL no.	M 39012/72 - 0001

V

### RIGHT ANGLE BULKHEAD RECEPTACLE

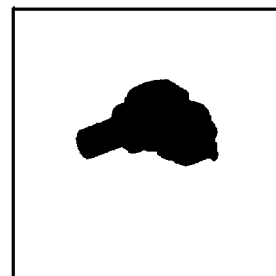
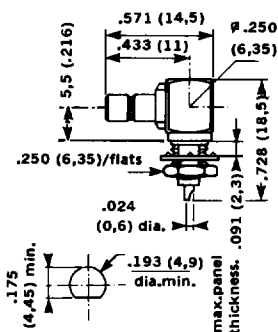

PART NUMBER	R 114 671
-------------	-----------

### RECEPTACLES FOR PRINTED CIRCUIT BOARD MOUNTING

#### STRAIGHT PCB RECEPTACLE

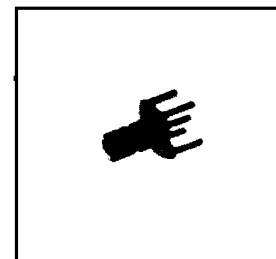
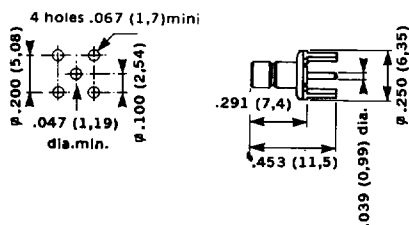

PART NUMBER	R 114 426
MIL no.	M 39012/95 - 0001

#### RIGHT ANGLE PCB RECEPTACLE

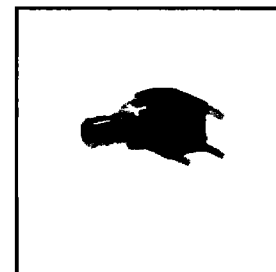
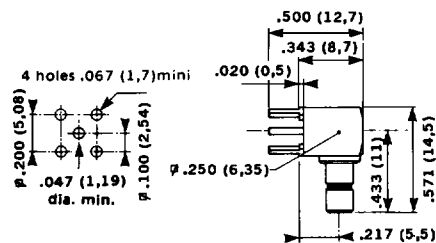

PART NUMBER	R 114 665
MIL no.	M 39012/96 - 0001

### MALE - MALE

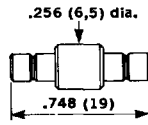
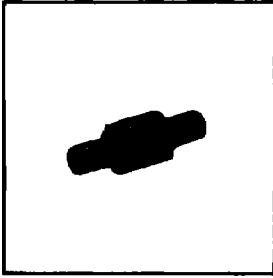

PART  
NUMBER

R 114 703

### FEMALE - FEMALE

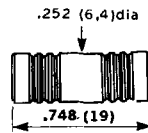
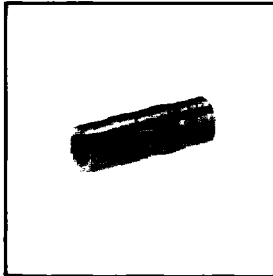

PART  
NUMBER

R 114 704

### MALE - MALE BULKHEAD

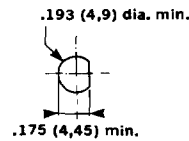
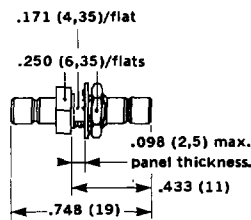
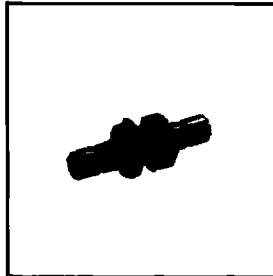

PART  
NUMBER

R 114 720

### MALE - MALE HERMETICALLY SEALED BULKHEAD

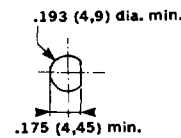
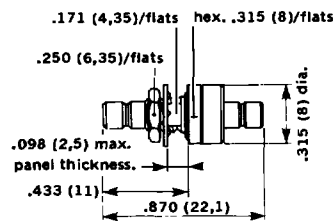
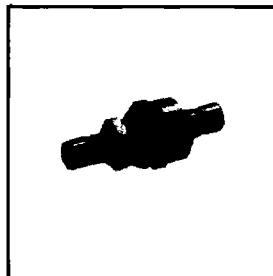

PART  
NUMBER

R 114 753

### TEE MALE - MALE/FEMALE

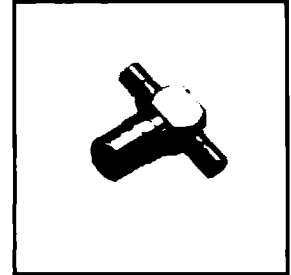
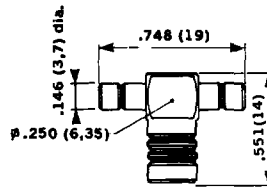

V

PART  
NUMBER

R 114 780

### TEE MALE - MALE/MALE

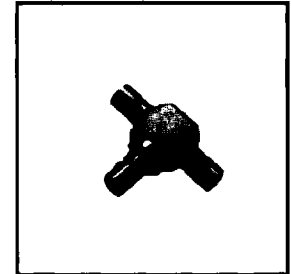
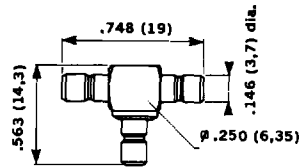

PART  
NUMBER

R 114 781

### TEE FEMALE - FEMALE/MALE

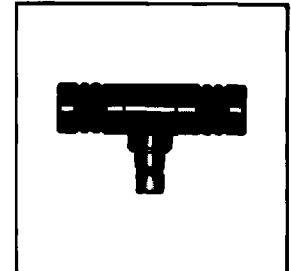
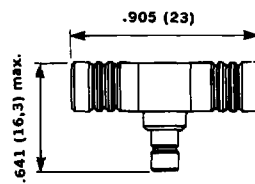

PART  
NUMBER

R 114 783

# SMB - A

## RECEPTACLES

These receptacles mate with all the SMB jacks and receptacles (male) and have a lower insertion and extraction force than the SMB connectors with which they mate, thereby avoiding any possible damage to printed circuit boards. The mate and demating force is between 0.56 and 1.35 Lbs (2.5 and 6 N).

### PLUG RECEPTACLE FOR PCB MOUNTING

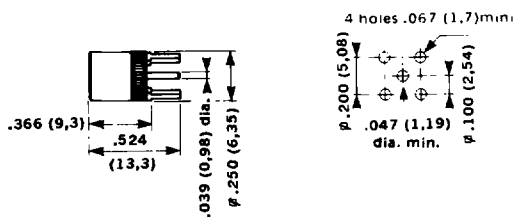
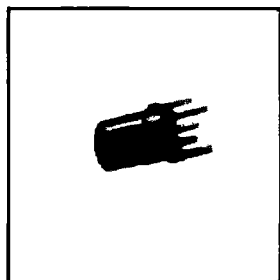

PART NUMBER	R 115 427
-------------	-----------

### BULKHEAD PLUG RECEPTACLE

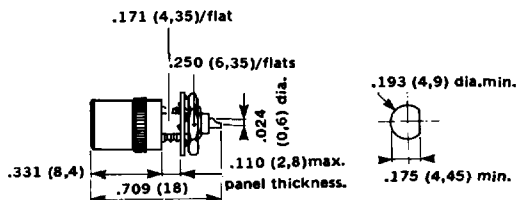
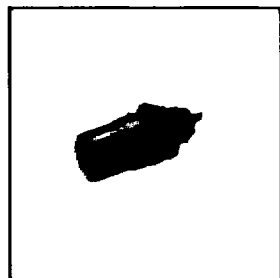

PART NUMBER	R 115 556
-------------	-----------

### RIGHT ANGLE PLUG RECEPTACLE FOR PCB MOUNTING

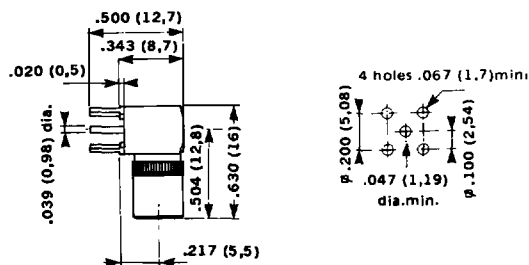
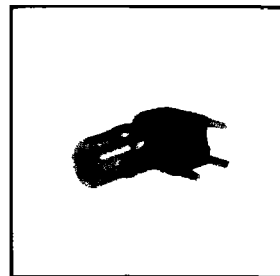

PART NUMBER	R 115 666
-------------	-----------

These slide on receptacles have no latching mechanism other than contact pressure. The low mate and demating force of between 0.50 and 1.10 Lbs (2.2 and 4.9 N) makes these connectors specially suited to rack and panel systems.



### JACK RECEPTACLE FOR PCB MOUNTING

PART NUMBER: R 116 426

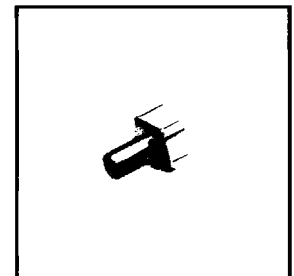
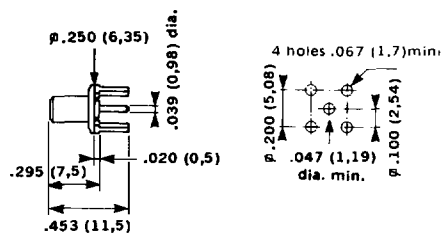

### BULKHEAD JACK RECEPTACLE

PART NUMBER: R 116 553

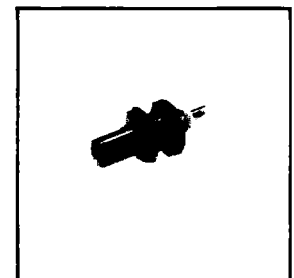
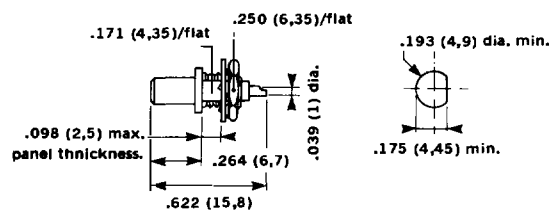

### BULKHEAD PLUG RECEPTACLE (FLOAT MOUNTING)

PART NUMBER: R 116 556

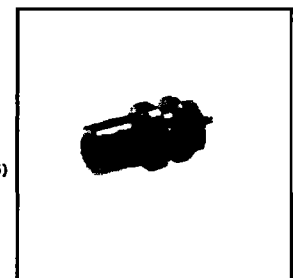
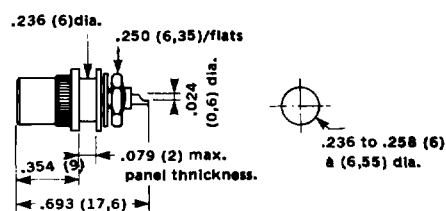

# MOUNTING INSTRUCTIONS

## M 01

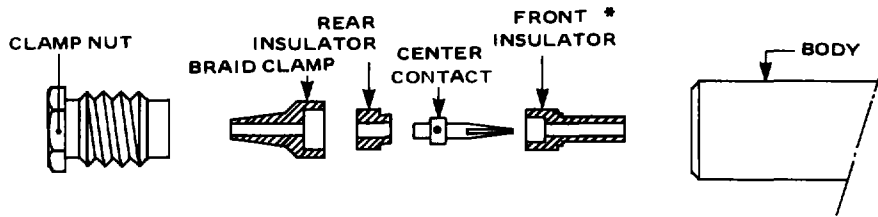

### CONNECTORS

R 114 003 133  
 R 114 005 133  
 R 114 203 133  
 R 114 205 133  
 R 114 303 133  
 R 114 305 133

1

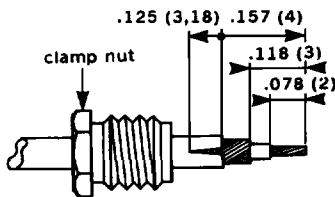

- 1 - 1 Mount the clamp nut
- 1 - 2 Strip off the cable then make 2 slits in the jacket 180° apart. longitudinally

2

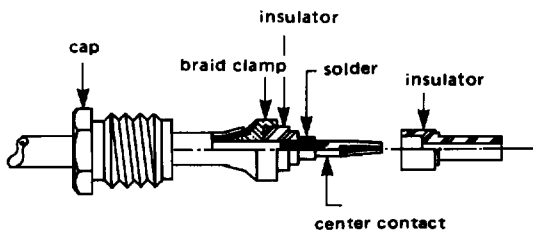

- 2 - 1 Mount the braid-clamp
- 2 - 2 Trim braid to Ø of braid-clamp
- 2 - 3 Solder the center contact
- 2 - 4 Mount the insulator

3

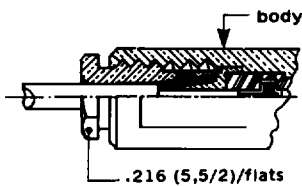

- 3 - 1 Screw the cable assembly into the connector body  
 Recommended coupling torque : 90 - 100 in. oz.

\* for R 114 003 133  
 R 114 005 133

# MOUNTING INSTRUCTIONS

## M 02

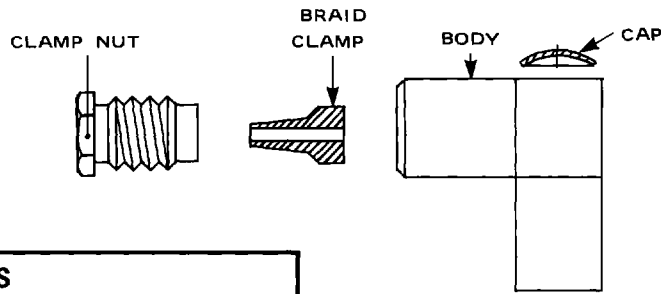

### CONNECTORS

R 114 163 133  
R 114 165 133

V

- 1 - 1 Mount the clamp nut
- 1 - 2 Strip off the cable then make 2 slits in the jacket 180° apart longitudinally

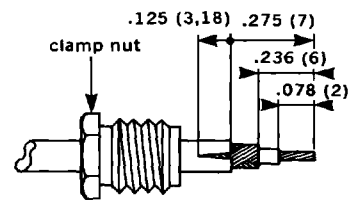

1

- 2 - 1 Mount the braid clamp
- 2 - 2 Strip off the cable

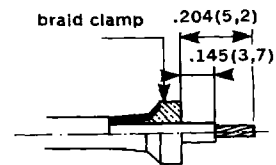

2

- 3 - 1 Mount and lock the cable clamp into the connector  
Coupling torque : 90 - 100 in. oz.
- 3 - 2 Solder the cable core on the center contact
- 3 - 3 Mount the cap.

press the cover into place with punch too

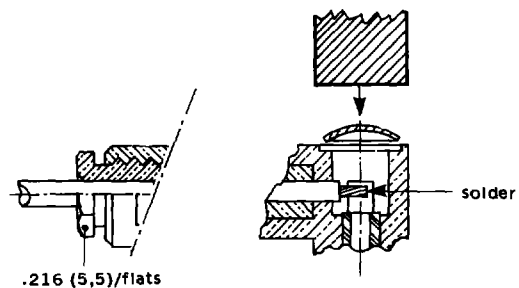

3

# MOUNTING INSTRUCTIONS

## M 03

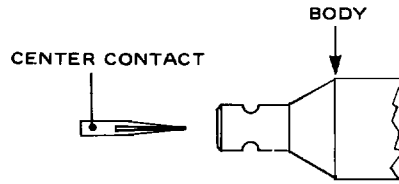

1

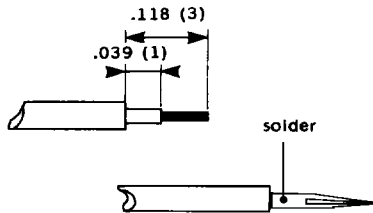

2

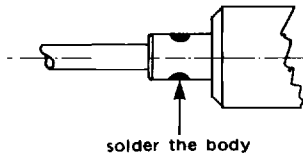

CONNECTOR

R 114 053

- 1 - 1 Cut the outer and dielectric
- 1 - 2 Solder the contact

- 2 - 1 Fit the sub-assembly into the body
- 2 - 2 Solder the body onto the semi-rigid

NOTE : In order to ensure correct positioning of the contact it is recommended that a receptacle is fitted to the plug prior to soldering the body.

# MOUNTING INSTRUCTIONS

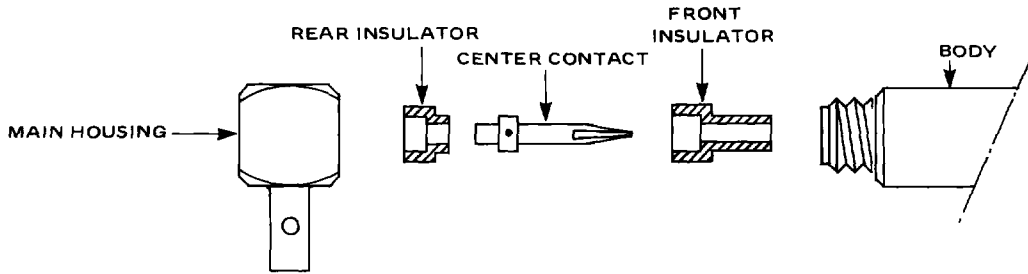

## M 04

<b>CONNECTOR</b>
<b>R 114 169</b>

V

1 - 1 Cut off the outer

- 2 - 1 Push the cable through the main housing
- 2 - 2 Solder the body onto the semi-rigid
- 2 - 3 Cut back the dielectric

- 3 - 1 Fit the rear insulator
- 3 - 2 Solder the contact ensuring that the contact has been pushed home into the rear insulator

- 4 - 1 Fit the front insulator
- 4 - 2 Fit the front body onto the sub-assembly

.276 to .315 (7 à 8)



1

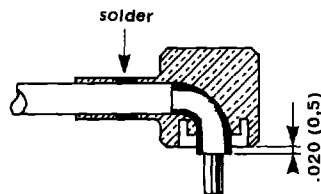

2

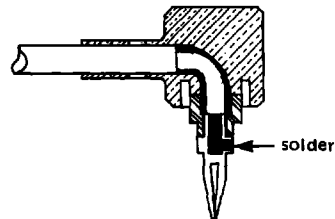

3

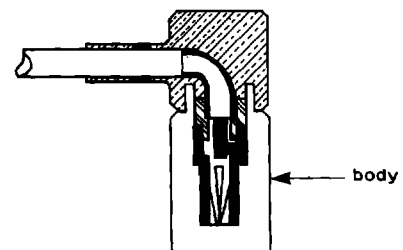

4

# MOUNTING INSTRUCTIONS

## M 05

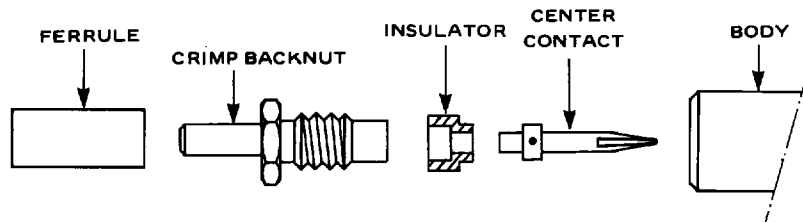

CONNECTORS	TOOLING	
R 114 073 134	RADIALL crimp tool	R 282 211
R 114 075 134	or RADIALL tool	R 282 240
R 114 237	+ RADIALL jaws	R 282 241
R 114 239	or BUCHANAN tool	612 648
R 114 311	+ BUCHANAN jaws	612 784
R 114 312	2 mm Ø cable :	.105 (2,67) Hex.
	2,6 mm Ø cable :	.120 (3,25) Hex.

1

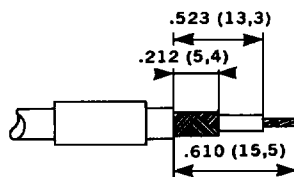

2

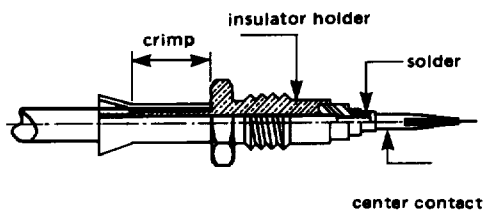

3

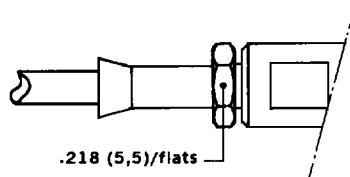

- 1 - 1 Mount the ferrule
- 1 - 2 Strip off the cable

- 2 - 1 Mount the insulator holder on the cable
- 2 - 2 Crimp the ferrule : Radiall tool R 280 240 + dies 280 241  
or Radiall tool R 282 211  
or Buchanan tool 612 648 + dies 612 784

- 2 - 3 Solder the cable core into the center contact

- 3 - 1 Mount the cable assembly into the connector body and screw  
Recommended coupling torque : 90 - 100 in. oz.

# MOUNTING INSTRUCTIONS

## M 06

CONNECTORS	TOOLING
<b>R 114 183</b> <b>R 114 186</b>	<b>RADIALL crimp tool R 282 211</b> or <b>RADIALL tool R 282 240</b> + <b>RADIALL jaws R 282 241</b> or <b>BUCHANAN tool 612 648</b> + <b>BUCHANAN jaws 612 784</b> 2 mm Ø cable : .105 (2,67) Hex. 2,6 mm Ø cable : .120 (3,25) Hex.

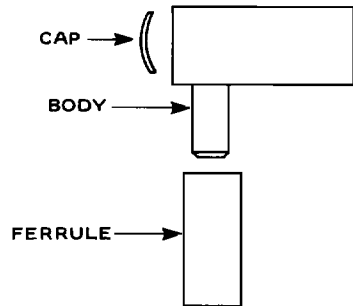

- 1 - 1 Mount the ferrule
- 1 - 2 Strip off the cable

1

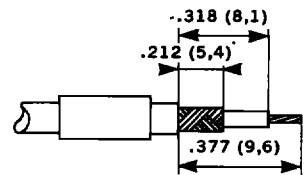

- 2 - 1 Mount the cable in the body and crimp the ferrule  
 Crimp the ferrule : Radiall tool R 280 240 + dies 280 241  
 or Radiall tool R 282 211  
 or Buchanan tool 612 648 + dies 612 784

2

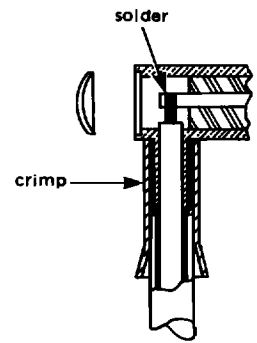

- 2 - 2 Solder the cable core on the center contact
- 2 - 3 Mount the cap

# MOUNTING INSTRUCTIONS

## M 07

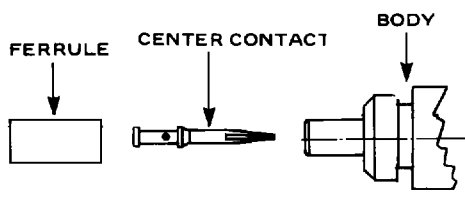

CONNECTORS	TOOLING
<b>R 114 082</b> <b>R 114 238</b> <b>R 114 313</b>	2 x 4 points crimping Crimping tool : Radiall R 282 281 or Buchanan 612 596 Position 1 Positioners : R 282 583 Crimping tool : Radiall R 282 211 Hex: .127 (3,25)

1

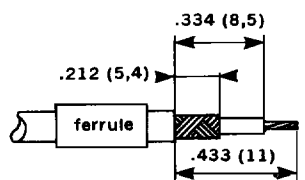

- 1 - 1 Mount the ferrule
- 1 - 2 Strip off cable

2

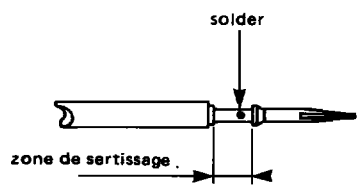

- 2 - 1 Mount the center contact on the core of cable. The center contact shall abut against the insert crimp, or solder.
- 2 x 4 points crimping  
 Crimping tool Radiall R 282 281 or Buchanan 612-596 position 1  
 Positioners : Radiall 282 983

3

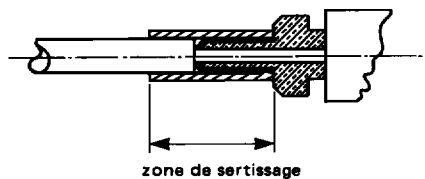

- 3 - 1 Pass body under braid then crimp the ferrule  
 Crimping tool : Radiall R 282 211  
 Hex: .127 (3,25)

# MOUNTING INSTRUCTIONS

## M 08

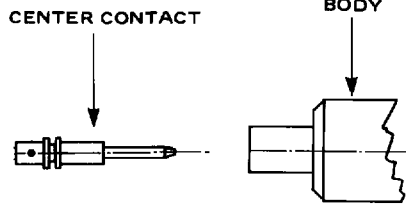

<b>CONNECTOR</b>
<b>R 114 222</b>

V

1 - 1 Strip off cable

1

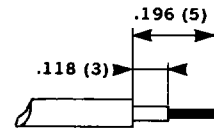

2 - 1 Solder the pin

2

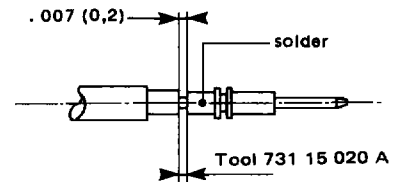

3 - 1 Solder the cable on the body

3

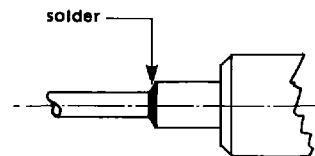

# MOUNTING INSTRUCTIONS

## M 09

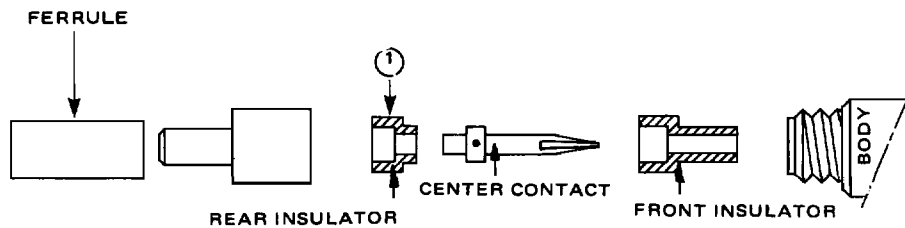

CONNECTOR	TOOLING
R 114 187	2 x 4 points crimping Crimping tool : Radiall R 282 281 or Buchanan 612 596 Position 3 Positioners : R 282 983 Crimping tool : Radiall R 282 211 Hex: .127 (3,25)

1

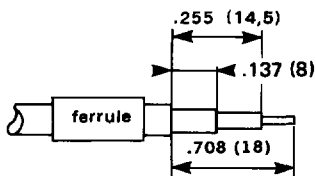

2

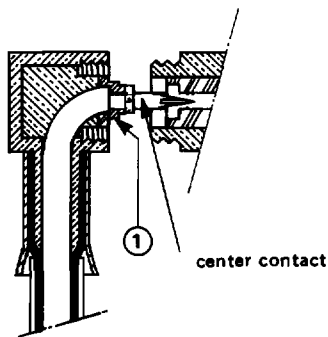

- 1 - 1 Mount the ferrule
- 1 - 2 Strip off the cable

- 2 - 1 Push the cable into the connector body
- 2 - 2 Mount the insulator ①
- 2 - 3 Crimp the center contact against the insulator.  
2 x 4 points crimping, crimping tool R 282 281 Buchanan 612 596, position 3 + positioners R 282 983.
- 2 - 4 Crimp the ferrule : Radiall tool R 282 211  
Hex : .127 (3,25)
- 2 - 5 Mount the front insulator on the center contact
- 2 - 6 Screw the front body into the cable assembly