

Description

The 1.6/5.6 series is a European design with two coupling versions: Threaded provides positive mating, Push-pull allows quick installation. Amphenol 1.6/5.6 coaxial connectors are miniature 75 ohm units operating from 0-1GHz.

The compact design of the 1.6/5.6 permits dense connector packing making these connectors ideally suited to applications where space limitation is a factor.

This series complies with DIN 47295, DIN 41626, DIN 47297, NFC 93-569, NFC 93-570, IEC 169-13, and the CECC 22230 standards.

For crimping the inner contact please use our standard tool M22520/2-01 and locator AC-Positioner K41.

Features/Benefits

- Meets IEC 169-13, DIN 47295 and NFC 93-570 international specifications designed for SMT.
- Plugs and bulkhead jacks are available in crimp-crimp termination versions to ensure high reliability in connector assembly and a lower cost installation method.
- Threaded coupling designed for quick connect/disconnect allows safe coupling.

Applications

- Base Stations
- Cable Assemblies
- Computer / LAN
- Routers
- Switching Equipment
- Telecom
- Wireless

1.6/5.6 Coaxial Connectors

Specifications

Electrical

Impedance	75 Ω
Frequency range	0-1 GHz
Voltage rating	330 volt peak
Contact resistance:	
Center contact	4 milliohm
Outer contact	2 milliohm
Insulation resistance:	10,000 MΩ

Mechanical

Mating	M9 x 0.5 threaded coupling
Cable affixment	(center conductor)
Crimp or solder	Captivated contacts
All crimps	

Material

Contacts	Male: Brass Female: (center and outer) Beryllium copper. Gold plated
Other metal parts	Brass, nickel plated
Insulators	Teflon
Crimp ferrule	Copper

Environmental

Temperature Range	- 40°C to +155°C
Connector Durability	500 matings

Note: These characteristics are typical but may not apply to all connectors.

Plug

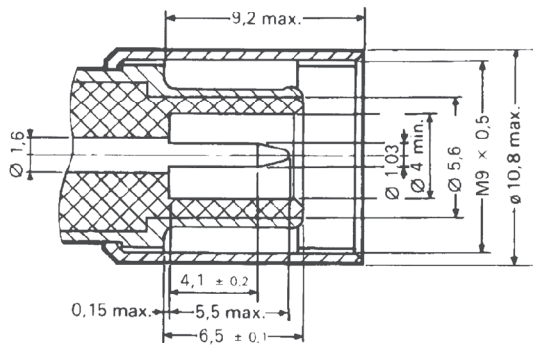

Jack

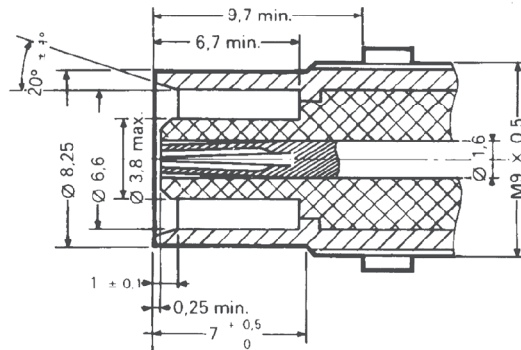

Straight Screw Plug Full Crimp

P.N.	Cable Group	Pit.	Ins.	Imp.	Tool Ferrule	Tool inner contact*
1561121AF-E06	6	Nickel	Teflon	75	Ace-tool 1	5
1561121AF-E16	16	Nickel	Teflon	75	Ace-tool 3	5
1561121AF-E16A	16A	Nickel	Teflon	75	Ace-tool 3	5**
1561121AF-E20	20	Nickel	Teflon	75	Ace-tool 2	5
1561121AF-E21	21	Nickel	Teflon	75	Ace-tool 2	6
1561121A1-E22	22	Nickel	Teflon	75	Ace-tool 3	5
1561121A1-E23	23	Nickel	Teflon	75	10	6
1561121AF-E24	24	Nickel	Teflon	75	Ace-tool 1	6
1561121AF-E25	25	Nickel	Teflon	75	Ace-tool 7	6

*crimp instruction inner contact, locator adjust to:

****(BT3002 to 3)**

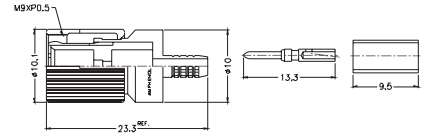

Assembly Instruction J - page 236

Push Pull Straight Plug Full Crimp

P.N.	Cable Group	Pit.	Ins.	Imp.	Tool Ferrule	Tool inner contact*
1561121L1-E06	6	Nickel	Teflon	75	Ace-tool 1	5
1561121LF-E16	16	Nickel	Teflon	75	Ace-tool 3	5
1561121LF-E16A	16A	Nickel	Teflon	75	Ace-tool 3	5**
1561121LF-E20	20	Nickel	Teflon	75	Ace-tool 2	5
1561121LF-E21	21	Nickel	Teflon	75	Ace-tool 2	6
1561121L1-E22	22	Nickel	Teflon	75	Ace-tool 3	5
1561121L1-E23	23	Nickel	Teflon	75	10	6
1561121LF-E24	24	Nickel	Teflon	75	Ace-tool 1	6
1561121L1-E25	25	Nickel	Teflon	75	Ace-tool 7	6

*crimp instruction inner contact, locator adjust to:

****(BT3002 to 3)**

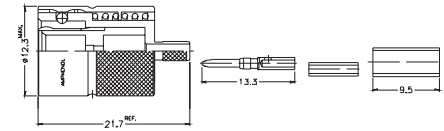
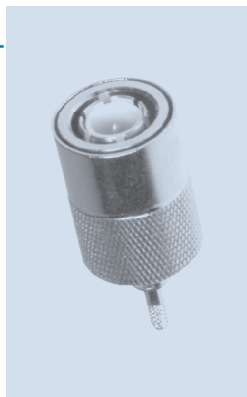

Assembly Instruction J - page 236

Push Pull Right Angled Plug Solder Crimp

P.N.	Cable Group	Pit.	Ins.	Imp.	Tool Ferrule	Tool inner contact*
1561112L2-E06	6	Nickel	Teflon	75	Ace-tool 1	N/A
1561112L1-E16	16	Nickel	Teflon	75	Ace-tool 3	N/A
1561112L1-E16A	16A	Nickel	Teflon	75	Ace-tool 3	N/A
1561112L1-E20	20	Nickel	Teflon	75	Ace-tool 2	N/A
1561112L1-E21	21	Nickel	Teflon	75	Ace-tool 2	N/A
1561112L2-E22	22	Nickel	Teflon	75	Ace-tool 3	N/A
1561112L1-E23	23	Nickel	Teflon	75	10	N/A
1561112L2-E24	24	Nickel	Teflon	75	Ace-tool 1	N/A
1561112L1-E25	25	Nickel	Teflon	75	Ace-tool 7	N/A

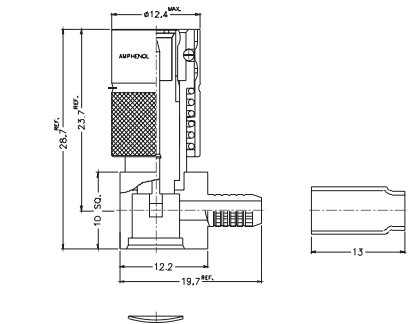
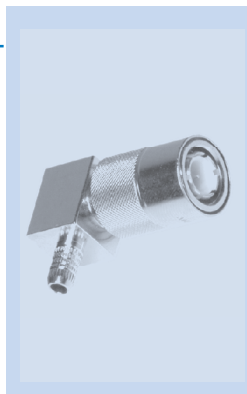

Assembly Instruction I - page 235

Right Angle Crimp Plug - Flexible Cable

P.N.	Cable Group	Pit.	Ins.	Imp.	Crimp Tool
1561112A1-N/3GT3G-6-75	06	Gold	Teflon	75	1
1561112A1-N/3GT3G-3-75	03	Gold	Teflon	75	4

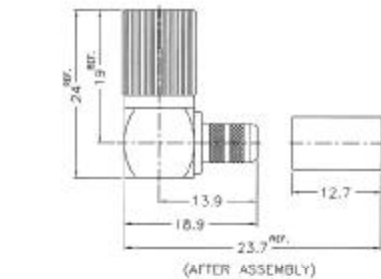

Assembly Instruction I - page 235

Bulkhead Receptacle Jack Full Crimp

P.N.	Cable Group	Pit.	Ins.	Imp.	Tool Ferrule	Tool inner contact *
1566421AF-E06	6	Gold	Teflon	75	Ace-tool 1	5
1566421AF-E16	16	Gold	Teflon	75	Ace-tool 3	5
1566421AF-E16A	16A	Gold	Teflon	75	Ace-tool 3	5**
1566421AF-E20	20	Gold	Teflon	75	Ace-tool 2	5
1566421AF-E21	21	Gold	Teflon	75	Ace-tool 7	6
1566421AF-E22	22	Gold	Teflon	75	Ace-tool 3	5
1566421A1-E23	23	Gold	Teflon	75	10	6
1566421AF-E24	24	Gold	Teflon	75	Ace-tool 1	6
1566421AF-E25	25	Gold	Teflon	75	Ace-tool 7	6

*crimp instruction inner contact, locator adjust to:
 **(BT3002 to 3)

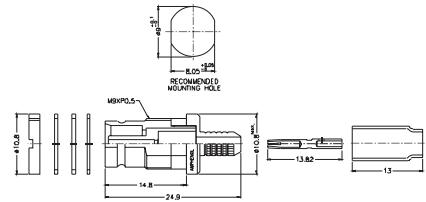
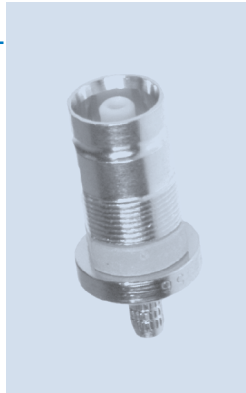

Bulkhead Right Angled Receptacle Solder Crimp

P.N.	Cable Group	Pit.	Ins.	Imp.	Tool Ferrule	Tool inner contact*
1566412AF-E06	6	Nickel	Teflon	75	Ace-tool 1	N/A
1566412A1-E16	16	Nickel	Teflon	75	Ace-tool 3	N/A
1566412AF-E16A	16A	Nickel	Teflon	75	Ace-tool 3	N/A
1566412A1-E20	20	Nickel	Teflon	75	Ace-tool 2	N/A
1566412AF-E21	21	Nickel	Teflon	75	Ace-tool 7	N/A
1566412A1-E22	22	Nickel	Teflon	75	Ace-tool 3	N/A
1566412A1-E23	23	Nickel	Teflon	75	10	N/A
1566412A1-E24	24	Nickel	Teflon	75	Ace-tool 1	N/A
1566412A1-E25	25	Nickel	Teflon	75	Ace-tool 7	N/A

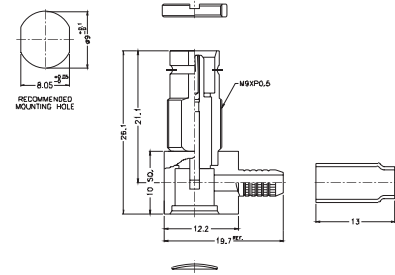

Straight Bulkhead Crimp Jack - Flexible Cable

P.N.	Cable Group	Pit.	Ins.	Imp.	Crimp Tool
1566421A1-N/3GT3G-6-75	06	Gold	Teflon	75	1
1566421A1-N/3GT3G-3-75	03	Gold	Teflon	75	4

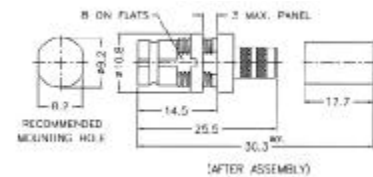
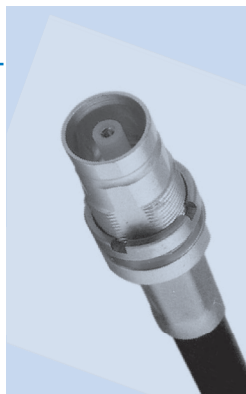

Assembly Instruction J - page 236

Straight Bulkhead Clamp Jack - Flexible Cable

P.N.	Cable Group	Plt.	Ins.	Imp.	Crimp Tool
1566441A1-N/3GT3G-6-75	06	Gold	Teflon	75	N/A
1566441A1-N/3GT3G-3-75	03	Gold	Teflon	75	N/A

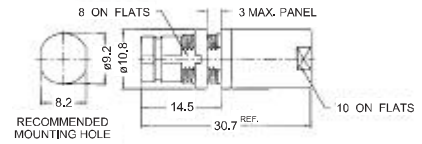

Assembly Instruction Y - page 251

Right Angle Bulkhead Clamp Jack - Flexible Cable

P.N.	Cable Group	Plt.	Ins.	Imp.	Crimp Tool
1566442A1-N/3GT3G-6-75	06	Gold	Teflon	75	N/A
1566442A1-N/3GT3G-3-75	03	Gold	Teflon	75	N/A

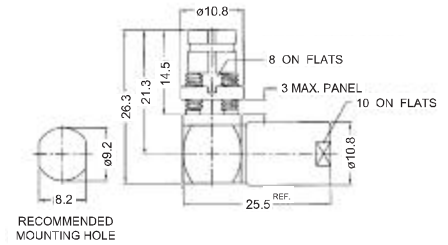
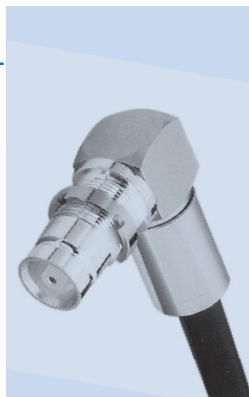

Assembly Instruction Y - page 251

Straight PCB Receptacle

P.N.	Cable Group	Plt.	Ins.	Imp.	Tool Ferrule	Tool Inner contact*
1566251AF-ES1	N/A	Gold	Teflon	75	N/A	N/A
1566251M1-ES2	N/A	Gold	Teflon	75	N/A	N/A
1566251AF-ES3	N/A	Gold	Teflon	75	N/A	N/A

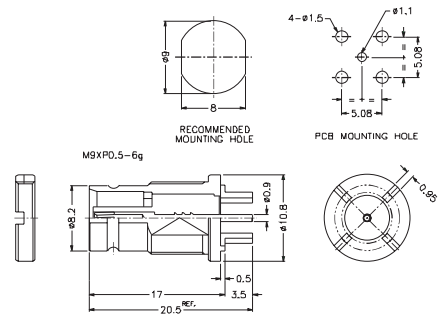
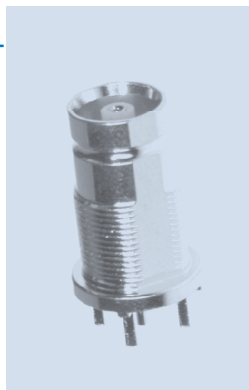

Right Angled PCB Receptacle

P.N.	Cable Group	Plt.	Ins.	Imp.	Tool Ferrule	Tool Inner contact*
1566252AF-ER1	N/A	Gold	Teflon	75	N/A	N/A
1566252AF-ER2	N/A	Gold	Teflon	75	N/A	N/A

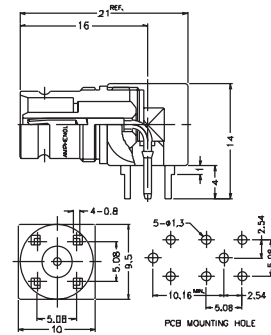
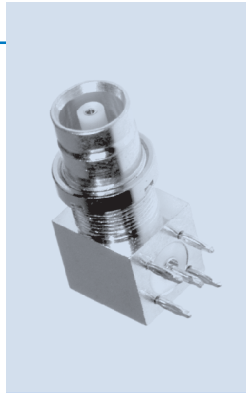

Straight Bulkhead Jack for P.C. Board

P.N.	Cable Group	Plt.	Ins.	Imp.	Crimp Tool
1566251M1-N/3GT3G-75	N/A	Gold	Teflon	75	N/A

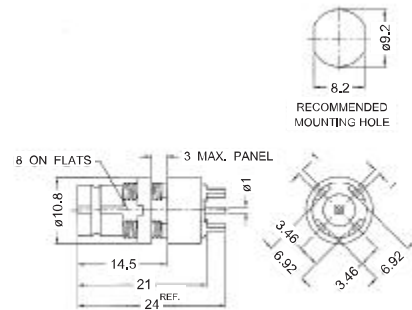
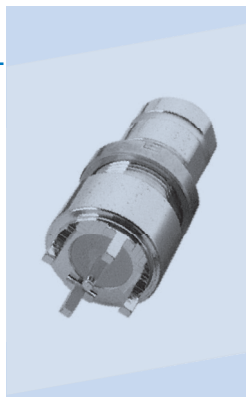

Assembly Instruction M - page 239

Straight Press fit jack

P.N.	Cable Group	Plt.	Ins.	Imp.	Tool Ferrule	Tool Inner contact*
1566251PF-ES1	N/A	Gold	Teflon	75	N/A	N/A
1566251PF-ES2	N/A	Gold	Teflon	75	N/A	N/A
1566251PF-ES3	N/A	Gold	Teflon	75	N/A	N/A
1566251PF-ES4	N/A	Gold	Teflon	75	N/A	N/A

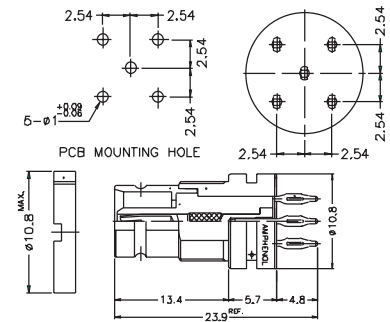

Adapters / U-Link

P.N.	Cable Group	Pit.	Ins.	Imp.	Tool Ferrule	Tool Inner contact*
1562076A2-P15	N/A	Nickel	Teflon	75	N/A	N/A
1562076A2-P30	N/A	Nickel	Teflon	75	N/A	N/A

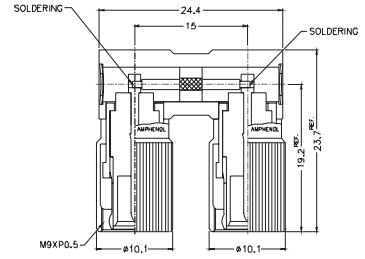
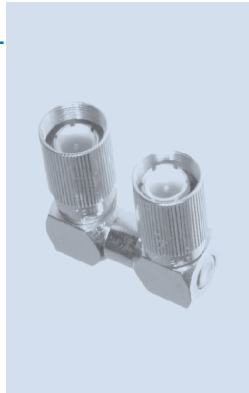

Plug-to-Plug Adapter

P.N.	Cable Group	Pit.	Ins.	Imp.	Crimp Tool
1562071A1-N/3GT3G-75	N/A	Gold	Teflon	75	N/A

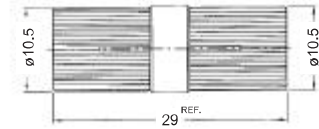
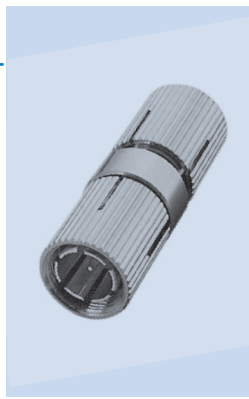

Plug-to-Jack-to-Plug 'Y' Link Adapter

P.N.	Cable Group	Pit.	Ins.	Imp.	Crimp Tool
1564077A1-N/3GT3G-75	N/A	Gold	Teflon	75	N/A
1564077A3-P15	N/A	Nicke	Teflon	75	N/A

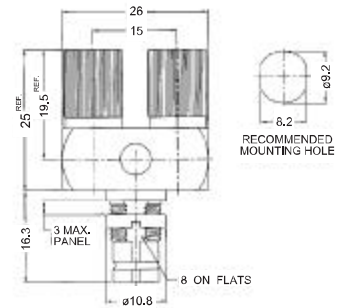
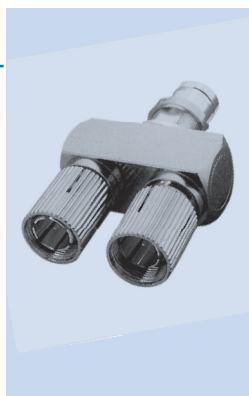

P.N.	Cable Group	Pit.	Ins.	Imp.	Crimp Tool
1567471A1-N/3GT3G-75	N/A	Gold	Teflon	75	N/A

