

74180

Parity Generator/Checker

9-Bit Odd/Even Parity Generator/Checker
Product Specification

Logic Products

FEATURES

- Word length easily expanded by cascading
- Generate even or odd parity
- Checks for parity errors
- See '280 for faster parity checker

DESCRIPTION

The '180 is a 9-bit parity generator or checker commonly used to detect errors in high speed data transmission or data retrieval systems. Both Even and Odd parity enable inputs and parity outputs are available for generating or checking parity on 8-bits.

True active-HIGH or true active-LOW parity can be generated at both the Even and Odd outputs. True active-HIGH parity is established with Even Parity enable input (P_E) set HIGH and the Odd Parity enable input (P_O) set LOW. True active-LOW parity is established when P_E is LOW and P_O is HIGH. When both enable inputs are at the same logic level, both outputs will be forced to the opposite logic level.

Parity checking of a 9-bit word (8 bits plus parity) is possible by using the two

TYPE	TYPICAL PROPAGATION DELAY, $P_O = 0V$	TYPICAL SUPPLY CURRENT
74180	36ns	34mA

ORDERING CODE

PACKAGES	COMMERCIAL RANGE $V_{CC} = 5V \pm 5\%$; $T_A = 0^\circ C$ to $+70^\circ C$
Plastic DIP	N74180N

NOTE:

For information regarding devices processed to Military Specifications, see the Signetics Military Products Data Manual.

INPUT AND OUTPUT LOADING AND FAN-OUT TABLE

PINS	DESCRIPTION	74
$I_0 - I_7$	Data inputs	1ul
P_E, P_O	Parity inputs	2ul
$\Sigma E, \Sigma O$	Parity outputs	10ul

NOTE:

A 74 unit load (ul) is understood to be $40\mu A$ I_{IH} and $-1.6mA$ I_{IL} .

enable inputs plus an inverter as the ninth data input. To check for true active-HIGH parity, the ninth data input is tied to the P_O input and an inverter is connected between the P_O and P_E inputs. To check for true active-LOW parity, the ninth data input is tied to the P_E input and an inverter is connected between the P_E and P_O inputs.

Expansion to larger word sizes is accomplished by serially cascading the '180 in 8-bit increments. The Even and Odd parity outputs of the first stage are connected to the corresponding P_E and P_O inputs, respectively, of the succeeding stage.

PIN CONFIGURATION

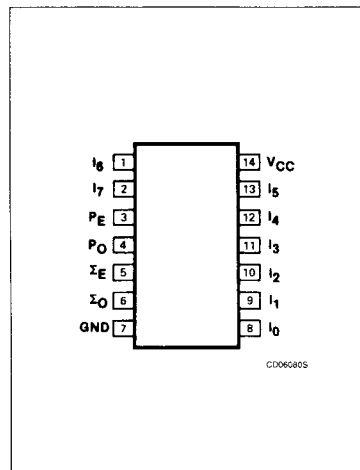

LOGIC SYMBOL

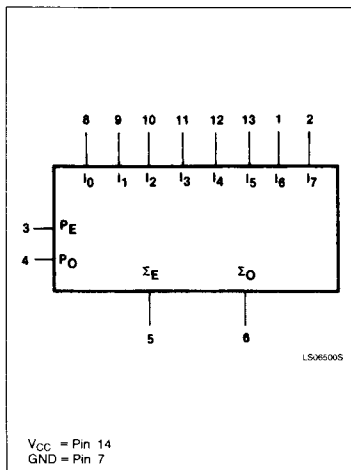

LOGIC SYMBOL (IEEE/IEC)

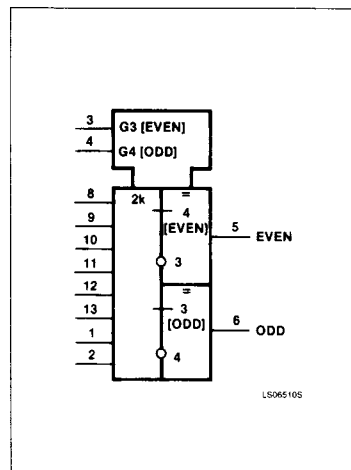

Parity Generator/Checker

74180

LOGIC DIAGRAM

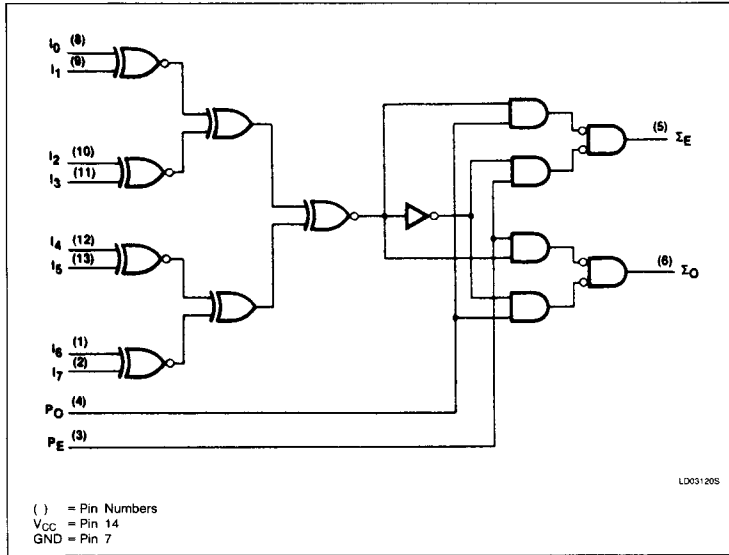

FUNCTION TABLE

INPUTS		OUTPUTS		
Number of HIGH Data Inputs (I ₀ - I ₇)	P _E	P _O	Σ _E	Σ _O
Even	H	L	H	L
Odd	H	L	L	H
Even	L	H	L	H
Odd	L	H	H	L
X	H	H	L	L
X	L	L	H	H

H = HIGH voltage level
 L = LOW voltage level
 X = Don't care

ABSOLUTE MAXIMUM RATINGS (Over operating free-air temperature range unless otherwise noted.)

PARAMETER		74	UNIT
V _{CC}	Supply voltage	7.0	V
V _{IN}	Input voltage	-0.5 to +5.5	V
I _{IN}	Input current	-30 to +5	mA
V _{OUT}	Voltage applied to output in HIGH output state	-0.5 to +V _{CC}	V
T _A	Operating free-air temperature range	0 to 70	°C

RECOMMENDED OPERATING CONDITIONS

PARAMETER	74			UNIT
	Min	Nom	Max	
V _{CC}	4.75	5.0	5.25	V
V _{IH}	2.0			V
V _{IL}			+0.8	V
I _{IK}			-12	mA
I _{OH}			-800	μA
I _{OL}			16	mA
T _A	0		70	°C

Parity Generator/Checker

74180

DC ELECTRICAL CHARACTERISTICS (Over recommended operating free-air temperature range unless otherwise noted.)

PARAMETER	TEST CONDITIONS ¹	74180			UNIT
		Min	Typ ²	Max	
V _{OH} HIGH-level output voltage	V _{CC} = MIN, V _{IH} = MIN, V _{IL} = MAX, I _{OH} = MAX	2.4	3.3		V
V _{OL} LOW-level output voltage	V _{CC} = MIN, V _{IH} = MIN, V _{IL} = MAX, I _{OL} = MAX		0.2	0.4	V
V _{IK} Input clamp voltage	V _{CC} = MIN, I _i = I _{IK}			-1.5	V
I _i Input current at maximum input voltage	V _{CC} = MAX, V _i = 5.5V			1.0	mA
I _{IH} HIGH-level input current	V _{CC} = MAX, V _i = 2.4V	I _O - I ₇ inputs		40	μA
		P _E , P _O inputs		80	μA
I _{IL} LOW-level input current	V _{CC} = MAX, V _i = 0.4V	I _O - I ₇ inputs		-1.6	mA
		P _{OE} , P _O inputs		-3.2	mA
I _{OS} Short-circuit output current ³	V _{CC} = MAX	-18		-55	mA
I _{CC} Supply current ⁴ (total)	V _{CC} = MAX		34	56	mA

NOTES:

- For conditions shown as MIN or MAX, use the appropriate value specified under recommended operating conditions for the applicable type.
- All typical values are at V_{CC} = 5V, T_A = 25°C.
- I_{OS} is tested with V_{OUT} = +0.5V and V_{CC} = V_{CC} MAX + 0.5V. Not more than one output should be shorted at a time and duration of the short circuit should not exceed one second.
- Measure I_{CC} with P_E and P_O inputs at 4.5V, all other inputs and outputs open.

AC ELECTRICAL CHARACTERISTICS T_A = 25°C, V_{CC} = 5.0V

PARAMETER	TEST CONDITIONS	74		UNIT
		C _L = 15pF, R _L = 400Ω		
		Min	Max	
t _{PLH} t _{PHL} Propagation delay Data to even output	Waveforms 1 & 2, P _O = 0V		60 68	ns
t _{PLH} t _{PHL} Propagation delay Data to odd output	Waveforms 1 & 2, P _O = 0V		48 38	ns
t _{PLH} t _{PHL} Propagation delay Data to even output	Waveforms 1 & 2, P _E = 0V		48 38	ns
t _{PLH} t _{PHL} Propagation delay Data to odd output	Waveforms 1 & 2, P _E = 0V		60 68	ns
t _{PLH} t _{PHL} Propagation delay P _E or P _O to output	Waveform 1		20 10	ns

Parity Generator/Checker

74180

AC WAVEFORMS

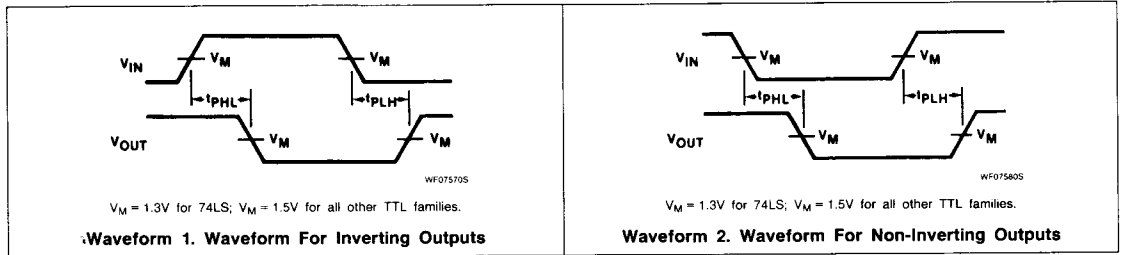

TEST CIRCUITS AND WAVEFORMS

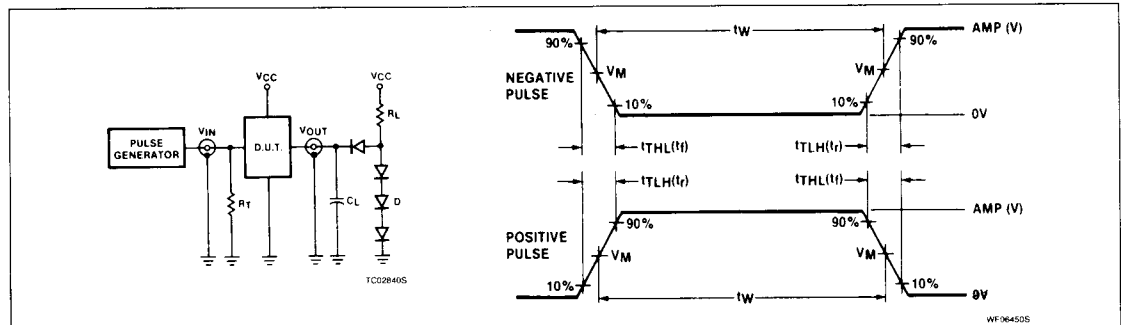

Test Circuit For 74 Totem-Pole Outputs

DEFINITIONS

R_L = Load resistor to V_{CC} ; see AC CHARACTERISTICS for value.

C_L = Load capacitance includes jig and probe capacitance; see AC CHARACTERISTICS for value.

R_T = Termination resistance should be equal to Z_{OUT} of Pulse Generators.

D = Diodes are 1N916, 1N3064, or equivalent.

t_{TLH} , t_{THL} Values should be less than or equal to the table entries.

Input Pulse Definition

FAMILY	INPUT PULSE REQUIREMENTS				
	Amplitude	Rep. Rate	Pulse Width	t_{TLH}	t_{THL}
74	3.0V	1MHz	500ns	7ns	7ns
74LS	3.0V	1MHz	500ns	15ns	6ns
74S	3.0V	1MHz	500ns	2.5ns	2.5ns

5