

LOGIC DIAGRAM

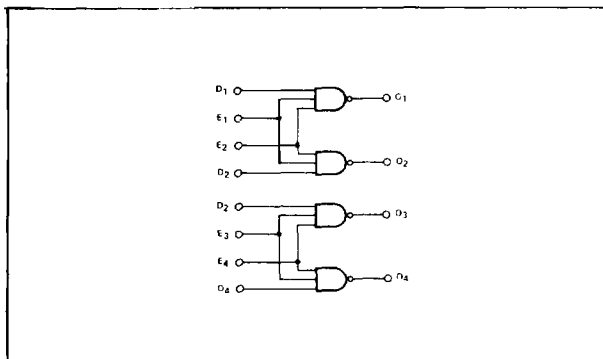

PIN CONFIGURATION

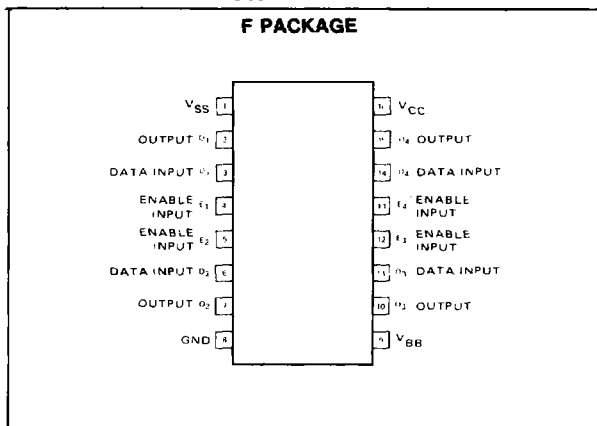

ABSOLUTE MAXIMUM RATINGS

Operating Temperature Range	0° to 70°C
Storage Temperature	-65° to +150°C
Input Voltage Ranges	-0.5 to +21VDC
V _{CC} Supply Voltage Range	-0.5 to +7.0VDC
Output Voltage Range (with respect to ground)	-0.5 to +25VDC
V _{SS} Voltage Range (with respect to ground)	-0.5 to +25VDC
V _{BB} Voltage Range	-0.5 to +25VDC

A.C. CHARACTERISTICS T_A = 0°C to 55°C, V_{CC} = 5V ±5%, V_{SS} = 19V ±5%, V_{BB} = V_{SS} + 3 to 4V, f = 2MHz, 50% Duty Cycle

PARAMETERS	DELAY DIFFERENTIAL (1) C _L = 200 pF max.	C _L = 100 pF		C _L = 200 pF	
		MIN	MAX	MIN	MAX
t _{+ -} INPUT TO OUTPUT DELAY	5	5	15	5	15
t _{- +} INPUT TO OUTPUT DELAY	10	5	25	5	25
t _r OUTPUT RISE TIME	10	5	20	5	30
t _f OUTPUT FALL TIME	10	5	20	10	30
t _D DELAY + RISE OR FALL TIME	10	10	35	20	45

(1) This is defined as the maximum skew between any output in the same package, e.g., all the input to output delays for the t_{+ -} parameter are within a maximum of 10nsec of each other in the same package.

D.C. CHARACTERISTICS T_A = 0°C to 55°C, V_{CC} = 5V ±5%, V_{SS} = 19V ±5%, V_{BB} - V_{SS} = 3.0V to 4.0V

PARAMETER	CONDITIONS	MIN	MAX	UNITS
I _{FD} Data Input Load Current	V _D = 0.45V, V _{CC} = 5.25V, All Other Inputs at 5.25V, V _{SS} = 16V, V _{BB} = 19V		-0.25	mA
I _{FE} Enable Input Load Current	V _E = 0.45V, V _{CC} = 5.25V, All Other Inputs at 5.25V, V _{SS} = 16V, V _{BB} = 19V		-0.50	mA
I _{RD} Data Input Leakage Current	V _D = 19V, V _{CC} = 5.0V, All Other Inputs Grounded, V _{SS} = 16V, V _{BB} = 19V		20	μA
I _{RE} Enable Input Leakage Current	V _D = 19V, V _{CC} = 5.0V, All Other Inputs Grounded, V _{SS} = 16V, V _{BB} = 19V		20	μA
C _{IN} INPUT CAPACITANCE	V _{BIAS} = 2.0V, V _{CC} = 0V		8 (Typical)	pF

D.C. CHARACTERISTICS (Cont'd) $T_A = 0^\circ\text{C to } 55^\circ\text{C}$, $V_{CC} = 5\text{V} \pm 5\%$, $V_{SS} = 19\text{V} \pm 5\%$, $V_{BB} - V_{SS} = 3.0\text{V to } 4.0\text{V}$

PARAMETER	CONDITIONS	MIN	MAX	UNITS
-----------	------------	-----	-----	-------

POWER SUPPLY CURRENT DRAIN:
All Outputs "Low"

I_{CC}	Current from VCC	$V_{CC} = 5.25\text{V}$, $V_{SS} = 20\text{V}$ $V_{BB} = 24\text{V}$ All Inputs Open		83	mA
I_{SS}	Current from VSS			250	μA
I_{BB}	Current from VBB			25	mA
P_{TOTAL}	Total Power Dissipation			1040	mW

All Outputs "High"

I_{CC}	Current from VCC	$V_{CC} = 5.25\text{V}$, $V_{SS} = 20\text{V}$ $V_{BB} = 24\text{V}$ All Inputs Grounded		33	mA
I_{SS}	Current from VSS			250	μA
I_{BB}	Current from VBB			5	mA
P_{TOTAL}	Total Power Dissipation			297	mW

STANDBY CONDITION WITH $V_{CC} = 0\text{V}$, $V_{SS} = V_{BB}$

I_{CC}	Current from VCC	$V_{CC} = 0\text{V}$, $V_{SS} = 20\text{V}$ $V_{BB} = 20\text{V}$		0	mA
I_{SS}	Current from VSS			500	μA
I_{BB}	Current from VBB			500	μA
P_{TOTAL}	Total Power Dissipation			15	mW