



EL2036C/EL2037C

Servo Motor Drivers

T-52-13-25

EL2036C/EL2037C

Features

- No crossover distortion
- Low output offset current
- Maximum output swing
- Short circuit protected
- Programmable park voltage
- Programmable transconductance
- Programmable bandwidth
- Chip enable function
- Drive low cost bipolar transistors
- Single sense resistor
- Minimum external components
- Small surface mount package

Applications

- Voice coil motor servo systems
- Winchester disk drives
- Optical disk drives
- Super floppy drives
- DC motor control

Ordering Information

Part No.	Temp. Range	Package	Outline #
EL2036CM	-25°C to +85°C	SOIC	MDP0027
EL2036CN	-25°C to +85°C	PDIP	MDP0031
EL2037CM	-25°C to +85°C	SOIC	MDP0027
EL2037CN	-25°C to +85°C	PDIP	MDP0008

Connection Diagram

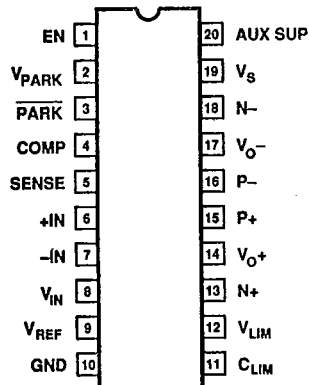

2036-1

General Description

The EL2036C and EL2037C are servo motor driver circuits designed to drive voice coil motors in disk drive applications. These second generation circuits contain more features, have improved accuracy, and are lower in cost compared to earlier generation circuits. The EL2036C/EL2037C drive an H bridge consisting of four low-cost external bipolar power transistors for maximum output swing. Crossover distortion is eliminated by Class AB biasing of the output devices with a unique patent pending temperature-stable circuit that never needs adjustment. The EL2036C/EL2037C protect the output transistors from short circuits by powering down for a programmed delay time when a fault occurs. When the fault is removed, the circuit returns to normal mode. This type of short circuit protection eliminates excessive power dissipation during faults and prevents overheating.

System accuracy is improved by using one external current sense resistor in series with the motor. Compared to conventional grounded resistor circuits, the EL2036C/EL2037C have inherent positive to negative gain matching and no gain error due to transistor alpha. All of the critical bias voltages use the same V_{REF} voltage. This reduces the output offset current to less than 5 mA.

In addition to an enable logic input, a "park" logic input has been provided which programs a voltage across the motor to park the head when power is removed. The power for this function comes from a separate supply generated by the back EMF of the spindle motor used as a generator. The EL2036C requires back EMF of 2.5V minimum, while the EL2037C requires back EMF of 3.5V minimum.

Block Diagram

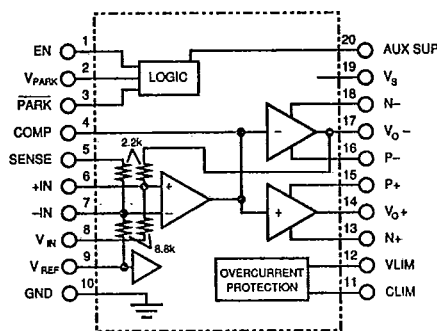

2036-2

Manufactured under U.S. Patent No. 4,910,477, 4,878,034, 4,935,704 and 4,963,802.



August 1989 Rev B

EL2036C/EL2037C**Servo Motor Drivers**

T-52-13-25

Absolute Maximum Ratings

V_S	Supply Voltage, Pin 19	-0.3V to +18V	T_A	Operating Temperature Range	-25°C to +85°C
V_{AUX}	Auxiliary Supply Voltage, Pin 20	$V_S - 1V$ to +18V		Lead Temperature	
V_{LIM}	Short Circuit Limit Sense Voltage	$V_S - 0.3V$ to +18V		DIP Package	300°C
V_{IN}	Logic Inputs, Pins 1 and 3	-0.3V to +7V		SOL Package	
	Signal Inputs, Pins 8 and 9	-0.3V to +7V		Vapor Phase (60 seconds)	215°C
I_{IN}	Input Current, Pins 1, 3, 8, and 9	10 mA		Infrared (15 seconds)	220°C
T_J	Junction Temperature	150°C	T_{ST}	Storage Temperature	-65°C to +150°C
			P_D	Power Dissipation, $T_A = 25^\circ\text{C}$	
				DIP Package	1.80W
				SOL Package	1.50W

Important Note:

All parameters having Min/Max specifications are guaranteed. The Test Level column indicates the specific device testing actually performed during production and Quality Inspection. Elantec performs most electrical tests using modern high-speed automatic test equipment, specifically the LTX77 Series system. Unless otherwise noted, all tests are pulsed tests, therefore $T_J = T_C = T_A$.

Test Level	Test Procedure
I	100% production tested and QA sample tested per QA test plan QCX0002.
II	100% production tested at $T_A = 25^\circ\text{C}$ and QA sample tested at $T_A = 25^\circ\text{C}$, T_{MAX} and T_{MIN} per QA test plan QCX0002.
III	QA sample tested per QA test plan QCX0002.
IV	Parameter is guaranteed (but not tested) by Design and Characterization Data.
V	Parameter is typical value at $T_A = 25^\circ\text{C}$ for information purposes only.

Electrical Characteristics

$T_A = T_J = 25^\circ\text{C}$, $V_S = 12V$, $V_{REF} = 5V$, $R_s = 0.25\Omega$, Load = 10 Ω . See test circuits

Parameter	Description	Min	Typ	Max	Test Level	Units
Enabled Mode, Pin 1 = H. Pin 3 = H. (Note 1)						
I_{OS}	Output Offset Current	-5	0.6	5	I	mA
G_{M1}	Transconductance, $I_{OUT} = \pm 100$ mA	0.95	1	1.05	I	A/V
G_{M2}	Transconductance, $I_{OUT} = \pm 1A$	0.93	1	1.07	I	A/V
I_{ST}	Quiescent Supply Current, Total		20		V	mA
I_{Q1}	Quiescent Supply Current, Pin 12 + 19	6	10	14	I	mA
I_{Q2}	Auxiliary Supply Quiescent Current, Pin 20	1	5	7	I	mA
I_{QE}	External Transistor Quiescent Current	2	8	12	I	mA
I_{DN}	NPN Drive Current, Pin 13 or 18	25	35		I	mA
I_{DP}	PNP Drive Current, Pin 15 or 16	25	35		I	mA
I_{IB}	Input Bias Current. $V_{IN} = V_{REF} = 2.5V, 6.5V$	-250	50	250	I	μA
I_{IA}	Active Input Current. $V_{IN} = 0.5V, V_{REF} = 2.5V$	-1.5	-1.1		I	mA
I_{IA}	Active Input Current. $V_{IN} = 4.5V, V_{REF} = 2.5V$		0.4	0.7	I	mA
I_{RB}	Reference Bias Current. $V_{IN} = V_{REF} = 2.5V, 6.5V$	-250	50	250	I	μA
I_{RA}	Active Reference Current. $V_{IN} = 0.5V, V_{REF} = 2.5V$	-1.5	-0.9		I	mA
I_{RA}	Active Reference Current. $V_{IN} = 4.5V, V_{REF} = 2.5V$		0.2	0.5	I	mA
V_S	Supply Voltage Range, Pin 19	11	12	13	IV	V
VRR	Reference Voltage Range, Pin 9	2.5		6.5	I	V
RRR	Reference Voltage Rejection, 2.5V to 6.5V		0.3	1	I	mA/V
PSR	Power Supply Rejection, 11V to 13V		0.3	1	I	mA/V
THD	Total Harmonic Distortion, $V_{IN} = 20$ mV _{PP} , 1 kHz		0.5	1	I	%

EL2036C/EL2037C

Servo Motor Drivers

EL2036C/EL2037C

T-52-13-25

Electrical Characteristics

$T_A = T_J = 25^\circ\text{C}$, $V_S = 12\text{V}$, $V_{REF} = 5\text{V}$, $R_s = 0.25\Omega$, Load = 10Ω . See test circuits — Contd.

Parameter	Description	Min	Typ	Max	Test Level	Units
Park Mode. Pin 1 = H. Pin 3 = L. Aux Supply (Pin 20) = 6V (Note 1) $R_{PARK} = 1.5k$, EL2036C, $R_{PARK} = 3k$, EL2037C						
V_{PI}	$V_{OUT} (V_{O+} - V_{O-})$ (EL2036)	-0.30	-0.45	-0.55	I	V
V_{PI}	$V_{OUT} (V_{O+} - V_{O-})$ (EL2037)	-0.40	-0.50	-0.60	I	V
V_{AR}	Aux Supply Range, EL2036C ($-0.25\text{V} \leq V_{OUT} \leq -0.65\text{V}$)	2.5	6	12	I	V
V_{AR}	Aux Supply Range, EL2037C ($-0.25\text{V} \leq V_{OUT} \leq -0.65\text{V}$)	3.5	6	12	I	V
I_{PD}	NPN Drive. Pin 13	2	3		I	mA
I_{AUX}	Short Circuit Maximum Current (Pin 17 = 0V)		250		V	mA
Disabled Mode. Pin 1 = L. Pin 3 = H. (Note 1)						
I_{OD}	Output Current	-200	10	200	I	μA
R_{OD}	Output Resistance. $I_{OUT} \pm 1\text{mA}$	1	3		I	$k\Omega$
I_{SD}	Total Supply Current, Pin 12, 19, and 20 + Transistors		10	14	I	mA
Short Circuit Protection						
V_{TR}	Trip Voltage. Pin 12-Pin 19	340	425	510	I	mV
I_C	Capacitor Charging Current	20	35	50	I	μA
I_D	Capacitor Discharge Current	1	3	10	I	mA
V_C	Capacitor Quiescent Voltage	8	9	10	I	V
Logic Inputs						
V_{IL}	Low Level Input Voltage for a Valid Low			0.8	I	V
I_{IL}	Low Level Input Current, Logic = 0V	-10	0	10	I	μA
V_{IH}	High Level Input Voltage for a Valid High	2			I	V
I_{IH}	High Level Input Current, Logic = 5V	-100	10	100	I	μA
Individual Amplifiers						
A_V	Power Amplifier Voltage Gain	9.5	10.7	12	I	V/V

Note 1: Logic Level L = 0.8V, Logic Level H = 2.0V

DC and Closed Loop AC Test Circuit

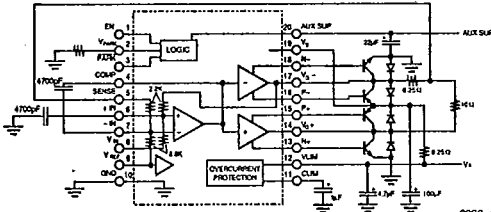

NPNs are MJE200.
PNPs are MJE210.
Diodes are 1 Amp IN4000.

2038-3

Open Loop AC Test Circuit

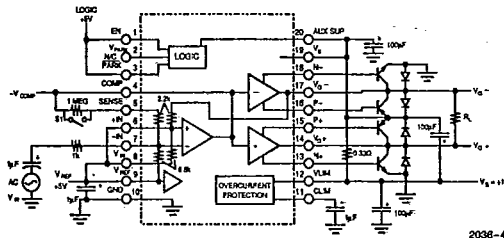

Op Amp Gain—S1 Open, $A_V = \frac{V_{COMP}}{V_{IN}}$

Power Amp Gain—S1 Closed, $A_V = \frac{(V_{O+}) - (V_{O-})}{V_{COMP}}$

2038-4

EL2036C/EL2037C

Servo Motor Drivers

T-52-13-25

Typical Performance Curves

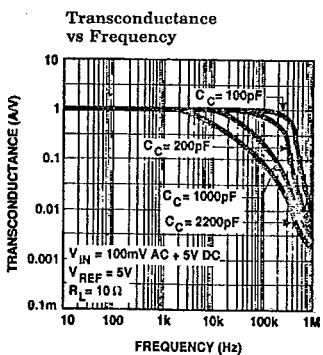
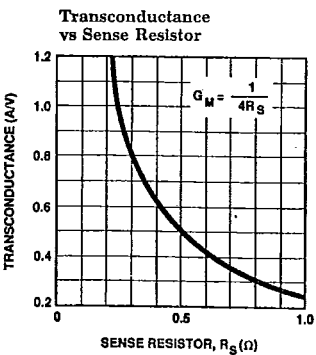
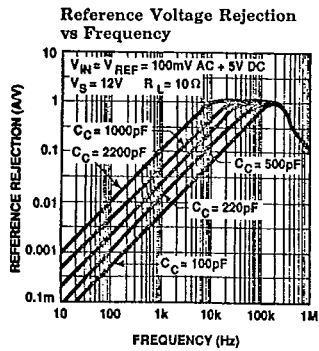
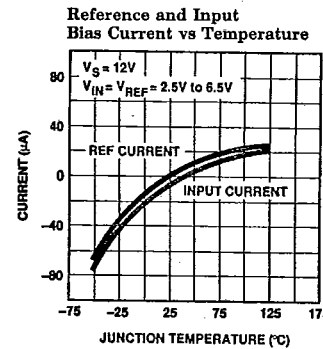
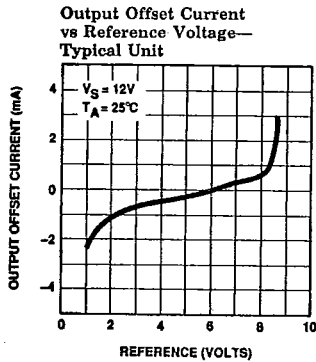
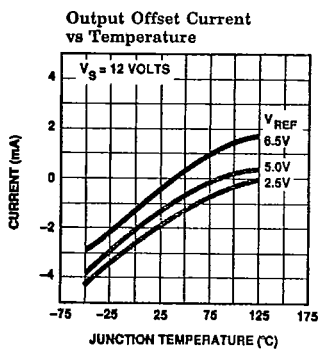
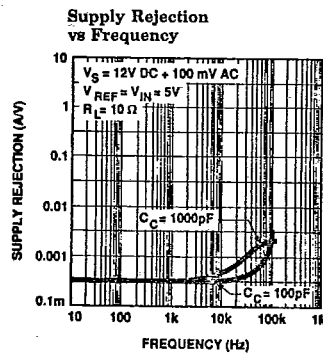
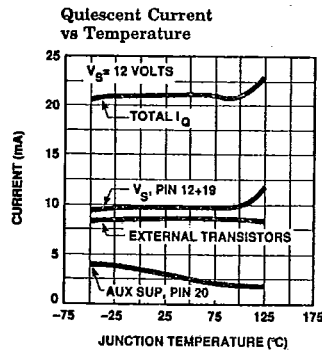
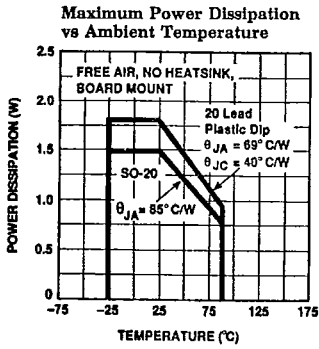

2036-5

EL2036C/EL2037C

Servo Motor Drivers

EL2036C/EL2037C

T-52-13-25

Typical Performance Curves — Contd.

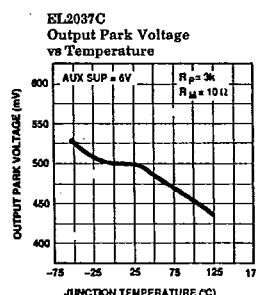
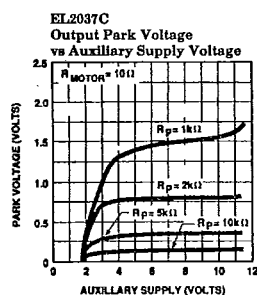
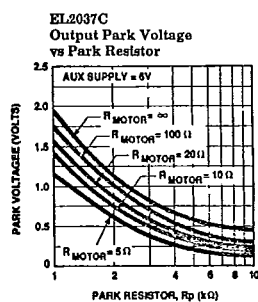
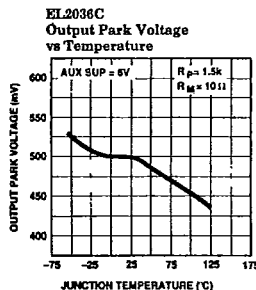
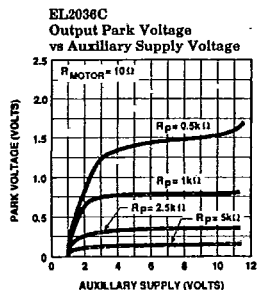
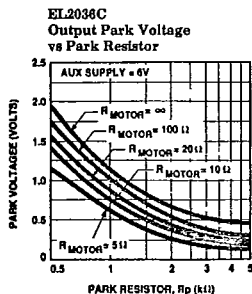

4

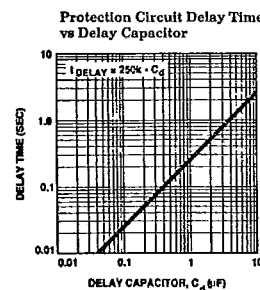
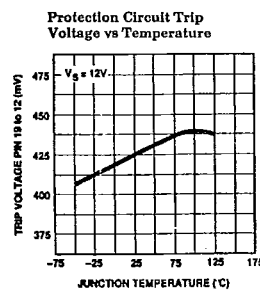
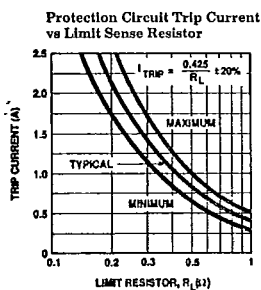
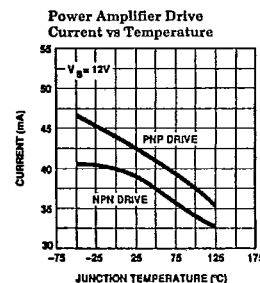
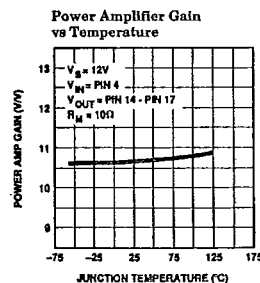
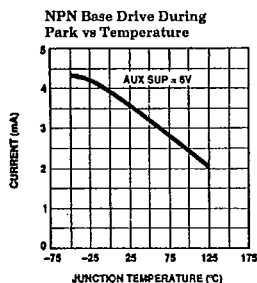

EL2036C/EL2037C

Servo Motor Drivers

T-52-13-25

Typical Application

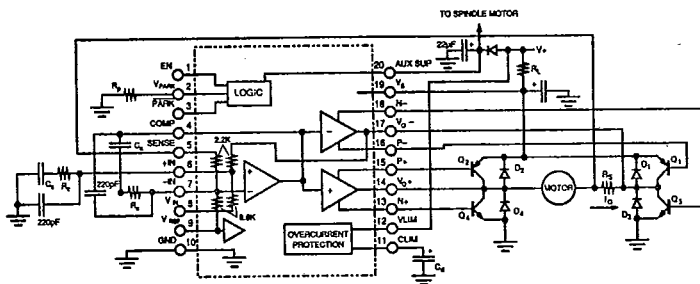

2036-7

External Components

Parameter	Description	Min	Typ	Max	Units	Typical ± % Tolerance
R _p	Sets the Motor Voltage During PARK Mode, EL2036C	0.5k	1.5k	Open	Ω	5
R _p	Sets the Motor Voltage During PARK Mode, EL2037C	1k	3k	Open	Ω	5
R _s	Current Sense Resistor	0.1	0.25	1	Ω	2
C _c	Loop Compensation. Sets dominant pole	100	2000	0.1 μF	pF	5
R _c	Loop Compensation. Makes a Zero, Equal to Motor Pole	0	10	200	kΩ	5
R ₁	Short Circuit Sense Resistor	0	0.33	3	Ω	5
C _d	Short Circuit Delay Capacitor	0.05	1	100	μF	10
D1-4	Catch diodes, 1 amp	1N4000				
Q1, 2	PNP Power Transistors. Min H _{FE} = 40	MJE210 or D45H11				
Q3, 4	NPN Power Transistors. Min H _{FE} = 40	MJE200 or D44H11				
R _p ≈ 0.7k/Park motor voltage (see the curves) for EL2036C and 1.4k/Park motor voltage for EL2037C						
R ₁ = 0.425/Trip current						
C _d = Delay/250k						
R _s = 1/(4*DC transimpedance)						

Truth Table

Enable (Pin 1)	Park (Pin 3)	V12 to V19	Output
> 2.0V	> 2.0V	< 0.34V	Normal Operation
< 0.8V	> 2.0V	< 0.34V	Disabled
X	< 0.8V	< 0.34V	Parking Mode
X	X	> 0.52V	Disabled for Delay

$$C_c = \frac{4 R_s}{800 (R_m + R_s) 2 \text{ pBandwidth}}$$

$$R_c = \frac{L_m}{C_c (R_m + R_s)}$$

Burn-In Circuit

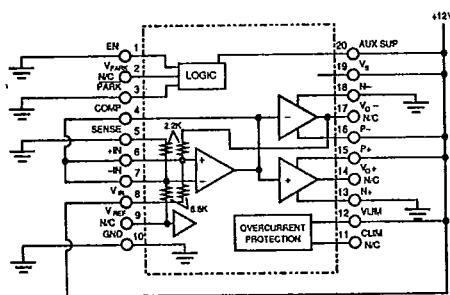

2036-8

EL2036C/EL2037C

Servo Motor Drivers

EL2036C/EL2037C

T-52-13-25

Circuit Description

The EL2036C/EL2037C are transconductance amplifiers especially well-suited to driving voice coil motors in disk drives. The EL2036C/EL2037C consist of five main blocks. These five functions are a low offset voltage operational amplifier, a single-ended input to differential output power amplifier, a short circuit protection circuit, a logic circuit and a park circuit.

The operational amplifier and power amplifier together with four well-matched internal resistors make the basic transconductance amplifier. The short circuit protection circuit senses the total supply current and shuts down the amplifiers if it exceeds a predetermined value. The logic circuit enables the amplifiers and the park circuit.

The Operational Amplifier

The operational amplifier is a low offset design with modest gain and excellent common mode rejection over a wide range that includes ground. This ensures proper operation when the motor voltage exceeds the supply or ground and is clamped by the catch diodes. The operational amplifier is internally compensated for stable operation at all times. The gain bandwidth product is 2 MHz and the phase margin is 60° at unity gain. The operational amplifier has internal clamps to limit its output swing to about ±2V of the reference voltage. The clamps are not shown in the simplified schematic and their only function is to prevent overcharging of the compensation capacitor during transients. The operational amplifier output is disabled by the logic circuit when either pin 1 or pin 3 is low.

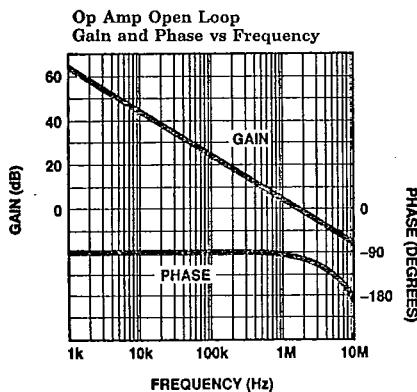

Figure 1

The Power Amplifier

The power amplifiers of the EL2036C/EL2037C are made of two identical stages that take a single-ended input and drive the motor differentially. The reference is buffered and the outputs of both stages are biased from the buffered reference voltage to reduce output offset current. Each stage has feedback for linearity and gain accuracy. One stage operates noninverting and the other inverting, resulting in a total gain of 11. The feedback is more complicated than shown in the simplified schematic, to ensure accurate gain even when one amplifier saturates before the other. The bandwidth of the power amplifier is about 500 kHz as shown below.

External power transistors deliver the power to the motor to optimize the output swing capability and eliminate power dissipation concerns. A unique biasing circuit eliminates low-level crossover distortion by biasing the transistors on at a few mA. The amplifier outputs are disabled when either pin 1 or pin 3 is low.

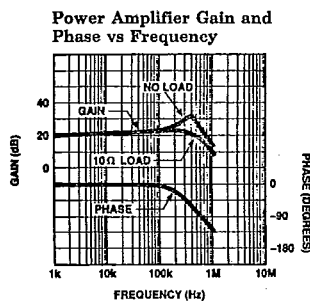

Figure 2

Short Circuit Protection Circuit

The short circuit protection circuit consists of a comparator, a floating reference, a flip flop and a one-shot. An external resistor, R₁ between pins 12 and 19 senses the total supply current the amplifiers pull from the supply. The floating reference subtracts 425 mV from the voltage sensed on pin 12 and the comparator trips when the voltage on pin 19 is at the same level. The net result is that when the drop across R₁ is 425 mV, the comparator trips. The output of the comparator sets a flip flop whose output disables the amplifiers and triggers the one-shot. When the one-shot starts timing, it resets the flip flop and the one-shot keeps the amplifiers off.

EL2036C/EL2037C**Servo Motor Drivers**

- T-52-13-25

EL2036C/EL2037C

Circuit Description — Contd.

The one-shot delay is set by an external capacitor, C_d . When the one-shot times out, the amplifiers are enabled again. If there is still a fault condition, the supply current rises until the comparator trips and the cycle repeats. Because the circuit is much faster than the one-shot delay time, the average power dissipation is very low. The circuit responds very quickly, in a few micro-seconds, so any current spike through R_1 will be detected and disable the amplifier for the delay time. The protection circuit will sometimes trip when there is a large, very fast, input signal. This is because there is a short but large spike of supply current. If this is a problem, the resistor R_1 should be bypassed with a large (about 100 μ F) capacitor.

The Logic Circuit

The logic circuit operates from a separate supply called the auxiliary supply. In a typical disk drive application, the auxiliary supply is usually within a diode drop of the normal supply, except when the normal supply is interrupted. Then the auxiliary supply is generated from the back EMF of the spindle motor. By having two supplies, the logic circuit can operate for a while after the main power has been removed.

There are two external inputs to the logic circuit, and one internal. The external inputs are enable and park-bar; the internal input is from the short circuit protection. The external inputs are TTL compatible and can be driven by CMOS gates. The internal short circuit protection input overrides the two external inputs. The park-bar input overrides the enable input when it is low. Note that when left open, the external inputs generate a logic low. Therefore, if the logic inputs are removed, the EL2036C/EL2037C go into park mode.

The Park Circuit

When the park-bar logic input is high, the park circuit is disabled and has no effect on the motor. When the park-bar logic input is low, the amplifiers are disabled and the park circuit is activated. Like the logic circuit, the park circuit uses the auxiliary supply, not the main supply. The park circuit sets the base of Q65 (the transistor whose emitter is pin 2) to about 2V. The value of the external resistor from pin 2 to ground, R_p , deter-

mines the current in the collector of the Q65 transistor. That current is mirrored and generates a voltage as it flows through two diodes, an internal resistor and a saturated transistor, Q68. The voltage is applied to the base of a darlington that drives V_{OUT-} , pin 17. At the same time, a current is sent to the base of the opposite output NPN transistor, pin 13. This saturates the external output NPN transistor. The voltage across the motor is now independent of the auxiliary supply voltage at pin 20 and is an inverse function of the resistor R_p .

Applications Information**Transconductance**

The DC transconductance of the EL2036C/EL2037C is set by one resistor, R_s , that senses the motor current. The input voltage is the difference between the voltage on pin 8 and 9. When pin 8 is more positive than pin 9, the input is said to be positive. When the input is positive, the voltage on pin 14 is more positive than pin 17 and the motor current is said to be positive. The DC transconductance is given by the simple equation:

$$G_{MO} = \frac{1}{4R_s} = \frac{I_O}{V_{IN} - V_{REF}}$$

For a transconductance of 1 Amp per volt, the sense resistor, R_s , should equal 0.25 Ω . Because the sense resistor is very small, care should be taken to insure that the PC board trace resistance does not increase its value. The connections from pin 5 and 17 are the "sense" connections while the motor and transistor collectors are the "force" connections. Therefore, the connections from pin 5 and pin 17 should go directly to the sense resistor.

Source Impedance

The input and reference source impedances should be low to prevent gain and offset errors. The input current is determined by the internal feedback resistors and the input and output voltages. The worst case current flows when the reference is low and the input is lower and therefore the V_{O-} output is high. This condition is tested and the input and reference currents are guaranteed to be less than 1.5 mA. Therefore, the input and reference should be able to sink and source

EL2036C/EL2037C

Servo Motor Drivers

T-52-13-25

EL2036C/EL2037C

Applications Information — Contd.

1.5 mA. For the typical case where the transconductance is 1 Amp per volt, a source impedance of less than 10Ω will generate less than 2.5 mA of additional output offset current and less than 1.5% gain error. Obviously, if the output of an operational amplifier drives the EL2036C/EL2037C there will be no errors due to source impedance. Be careful with some single supply operational amplifiers (324 and 358 types). They require output loading to ground to eliminate their high output impedance and crossover distortion.

Transistors

The EL2036C/EL2037C will drive almost any pair of complementary transistors. The output transistor drive is guaranteed to be 25 mA. The required maximum output current divided by 25 mA gives the minimum H_{FE} required. For 1 Amp output current, the minimum H_{FE} is 40.

The important specifications for the output devices are:

BV_{CEO}	Minimum 15V
H_{FE}	Minimum 40 at 1 Amp
f_t	40 MHz or more
$V_{CE(SAT)}$	As low as possible

The MJE200 and MJE210 series are excellent with minimum H_{FE} of 45 and saturation voltages of only 300 mV at 1 Amp. The D44H11 and D45H11 series have even lower saturation voltages and a higher H_{FE} of 60. Both types are available in surface mount from Motorola, SGS and others.

Motor Characterization

The formulas for the compensation of the EL2036C/EL2037C are based on the electrical characteristics of the motor. For most high-performance voice coil motors, the effective impedance is a function of frequency that can not be modeled over a large frequency range with a simple resistor and inductor. Fortunately, for the compensation equations to work, it is only necessary to model the motor at the bandwidth frequency.

The easiest way to determine the resistance and inductance of a motor is to use an RLC meter that reads the inductance and resistance at the

bandwidth frequency. If such a meter is not available, a network analyzer and a current probe will give the impedance versus frequency. From the magnitude and phase at the bandwidth frequency, the real and imaginary impedance can be calculated (and the imaginary part converted to inductance). Some network analyzers will even give the real and imaginary impedances directly.

The setup below was used to generate the following curve of impedance versus frequency on a real motor. At 10 kHz the impedance is 13Ω at 52° . This is 8Ω real and 10.25Ω reactive. Notice that the DC resistance is much less than the impedance at 10 kHz. The equivalent inductance is $163\mu\text{H}$.

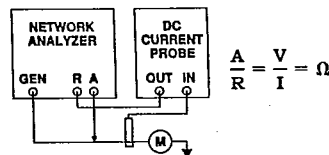

Figure 3. Motor Characterization Setup

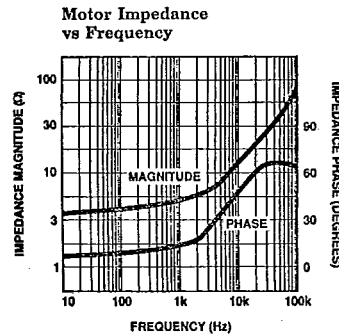

Figure 4

Compensation

The compensation components, C_c and R_c , are calculated to give the desired transconductance bandwidth. The equivalent motor resistance and inductance, R_m and L_m , the value of the sense resistor, R_s , and the bandwidth, BW, are used to compute C_c and R_c . The EL2036C/EL2037C require two identical networks for compensation. Each network is a series connection of a resistor, R_c , and a capacitor, C_c . The matching of the components is not critical, standard five percent tolerance is sufficient. The derivation of the fol-

EL2036C/EL2037C**Servo Motor Drivers**

T-52-13-25

Applications Information — Contd.
Following equations is in the AC Response Section.

$$C_c = \frac{4 R_s}{800 (R_m + R_s) 2\pi BW}$$

$$R_c = \frac{L_m}{(R_m + R_s) C_c}$$

To compensate the motor described in the previous section for a 10 kHz bandwidth and a transconductance of 1 Amp per volt we substitute

$$R_s = 0.25 \quad L_m = 160 \mu\text{H}$$

$$R_m = 8\Omega \quad BW = 10 \text{ kHz}$$

into the above equations.

$$C_c = \frac{4(0.25)}{800(8+0.25)(2)(3.14)(10 \text{ kHz})} = 2400 \text{ pF}$$

use 2200 pF

$$R_c = \frac{160 \text{ mH}}{(8+0.25)(2200 \text{ pF})} = 8800$$

use 10k.

Two 220 pF capacitors between pin 4 and pin 7, and between pin 6 and Ground (as shown in the Typical Application drawing on page 6) smooth fast rising input signals to ensure that the operational amplifier will not slew rate limit. Both capacitors can be eliminated if the slew rate of the input signal does not exceed 0.5 V/ μ s.

Park Function

The EL2036C/EL2037C will force a constant voltage across the motor when pin 3, park-bar, is open or low. The output voltage is negative; pin 14 if forced to about zero volts and pin 17 to the constant voltage determined by the resistor R_p from pin 2 to ground. This voltage drive produces a constant velocity that is used to park the heads. The power to drive the motor is supplied from an auxiliary supply (Aux Sup) on pin 20. Usually this auxiliary supply is the normal supply reduced by a diode drop. The spindle motor also is tied to the auxiliary supply. Once the normal supply drops, the spindle motor back EMF acts as a generator and holds the voltage up long enough for the drive to park the heads. An external bypass capacitor is needed on pin 20 to filter the ripple. To determine the value of the resistor

required from pin 2 to ground use the curve of Output Park Voltage versus Park Resistor (page 5).

Protection Circuit

The EL2036C/EL2037C have a protection circuit that prevents damage if either of the motor terminals is shorted to ground. The circuit senses the total supply current with a resistor, R_1 , and disables the amplifiers during over-current conditions. The curve of Protection Circuit Trip Current versus Limit Sense Resistor (page 5) should be used to select the proper resistor. For a typical 1 Amp output current the resistor should equal 0.33 Ω .

AC Response

The AC response of the EL2036C/EL2037C is set by the motor electrical time constant and the compensation impedance $Z(s)$. The actual circuit is quite difficult to analyze due to the differential techniques used to improve accuracy. To simplify the analysis, a single-ended system can be modeled with a summer, a forward path, the motor electrical elements and a feedback path. The forward path has a gain that includes the compensation components, and the feedback includes the current sense resistor, R_s . In this way we can solve for the response in terms of the actual EL2036C/EL2037C external component values.

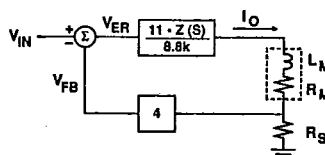

2036-13

Figure 5. The Servo Motor Loop Equivalent Circuit

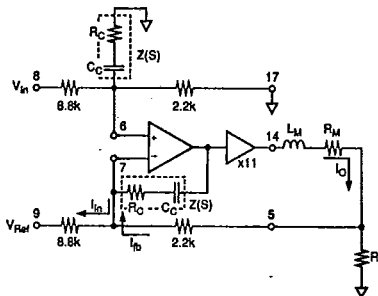

2036-14

Figure 6. The Servo Motor Control Equivalent Circuit

EL2036C/EL2037C

Servo Motor Drivers

EL2036C/EL2037C

T-52-13-25

AC Response — Contd.

The forward path gain of this circuit is the output current divided by the input voltage without any feedback.

$$A = \frac{I_o}{V_{IN}} = \frac{11Z(s)}{8.8K(sL_m + R_m + R_s)}$$

The feedback path is the feedback voltage divided by the output current.

$$b = \frac{V_{FB}}{I_o} = 4R_s$$

The closed loop response is therefore:

$$A_{CL} = \frac{A}{1 + A\beta} = \frac{\frac{1}{\beta}}{1 + \frac{1}{A\beta}}$$

$$= \frac{1}{4R_s} \frac{1}{1 + \frac{800}{4R_s} \left(\frac{sL_m}{R_m + R_s} + 1 \right) \left(\frac{R_m + R_s}{Z(s)} \right)}$$

The compensation network $Z(s)$ is usually a series resistor and capacitor, R_c and C_c . That is to say

$$Z(s) = R_c + \frac{1}{sC_c} = \frac{sR_cC_c + 1}{sC_c}$$

Substituting this into the closed loop equation gives

$$A_{CL} = \frac{1}{4R_s} \frac{1}{1 + \frac{800}{4R_s} \left(\frac{sL_m}{R_m + R_s} + 1 \right) \frac{(R_m + R_s)sC_c}{(sR_cC_c + 1)}}$$

There are many ways to analyze this for the desired response. Bode plots, Nyquist plots and root locus techniques can all be used to determine the values of R_c and C_c for a particular motor. The simplest way to obtain the values of R_c and C_c is to make the zero due to them equal to the motor pole.

$$R_c C_c = \frac{L_m}{R_m + R_s}$$

Substituting this constraint into the closed loop equation results in a single pole system. The equation is:

$$A_{CL} = \frac{1}{4R_s} \frac{1}{\frac{800}{4R_s} (R_m + R_s) s C_c + 1}$$

The closed loop -3 dB bandwidth (BW) is where the magnitude of the real and imaginary parts of the denominator are equal. We therefore can say, in terms of bandwidth in Hertz, that

$$\frac{800}{4R_s} (R_m + R_s) 2\pi \cdot BW \cdot C_c = 1$$

Solving these for C_c and R_c gives:

$$C_c = \frac{4R_s}{800(R_m + R_s)2\pi BW}$$

$$R_c = \frac{L_m}{(R_m + R_s)C_c}$$

Simplified Schematic

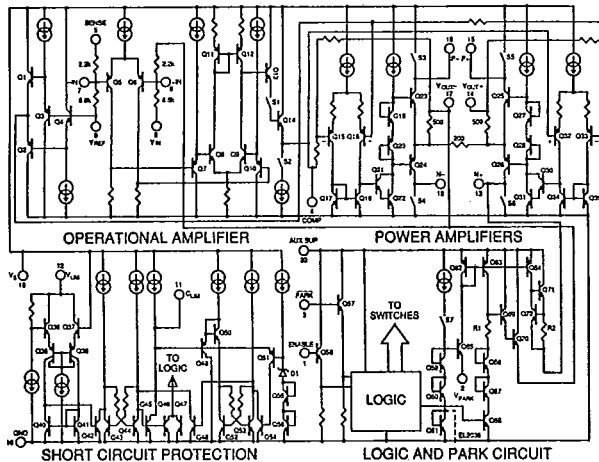

Figure 7

2036-15