

4-Bit Full Adder

The 41FL(M) device is a bipolar, NPN, sealed junction, silicon integrated circuit. It is available in a 16-pin plastic DIP.

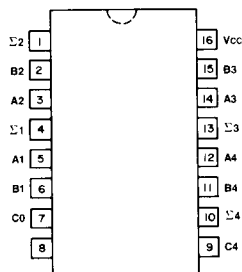

Truth Table

Inputs									Outputs				
C0	A1	B1	A2	B2	A3	B3	A4	B4	Σ1	Σ2	Σ3	Σ4	C4
H	L	L	H	L	L	H	H	L	H	H	H	H	L
H	L	L	H	H	L	H	L	H	H	L	L	L	H
H	H	L	L	L	L	L	L	H	L	H	L	H	L
L	H	H	H	L	L	H	L	H	L	L	L	L	H
H	L	H	H	L	L	H	L	H	L	L	L	L	H
H	L	L	L	H	L	L	L	H	H	H	L	H	L
H	H	L	L	L	H	H	L	H	L	H	L	L	H
H	H	L	L	L	H	H	L	H	L	H	H	L	H
H	L	L	H	L	L	L	L	H	H	L	H	H	L
L	H	L	H	L	L	H	H	L	H	H	H	H	L
L	L	L	H	H	H	L	H	L	L	L	L	L	H
L	L	L	H	H	H	L	L	L	L	L	L	L	H
L	L	L	H	H	L	L	L	L	L	L	H	L	L
H	H	H	L	L	H	L	H	L	H	H	H	H	L
H	L	L	H	L	H	L	H	H	H	H	H	L	H
H	H	H	L	L	H	L	H	H	H	H	H	L	H
L	H	L	L	L	L	H	H	H	H	L	H	L	H
H	H	H	L	H	L	L	H	H	H	L	H	L	H

H = High Level

L = Low Level

41FL(M)

Logic Diagram

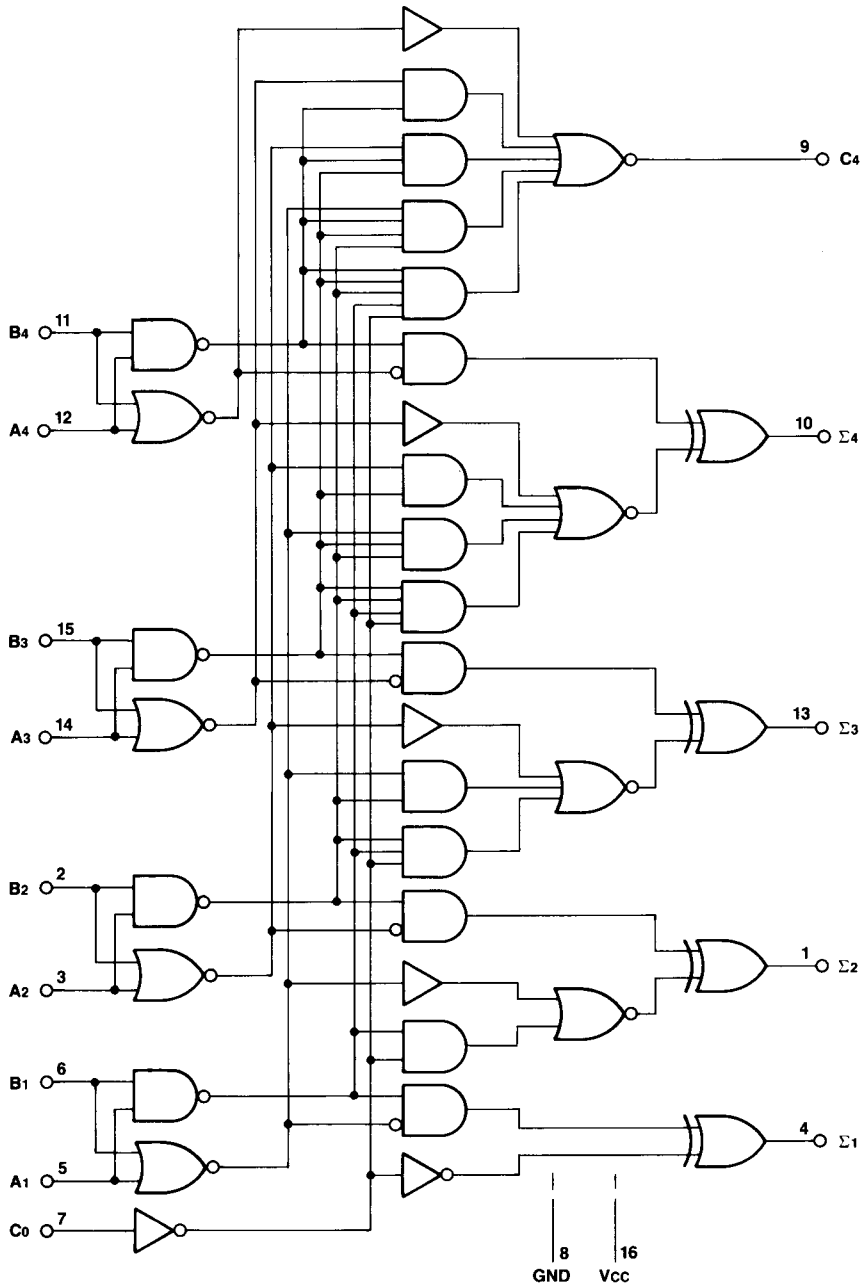

Electrical CharacteristicsV_{CC} = 5.0 ±0.5 V, T_J = 0 to 85 °C

Parameter	Symbol	Test Conditions	MTTL Family			Unit
			41FL Device			
			Min	Typ	Max	
Output Voltage						
High	V _{OH}	V _{CC} =4.5 V, I _{OH} =-4.0 mA	2.4	3.5	—	V
Low	V _{OL}	V _{CC} =4.5 V, I _{OL} =9.8 mA	—	0.35	0.5	V
Input Voltage						
High	V _{IH}	—	1.8	—	—	V
Low	V _{IL}	—	—	—	0.8	V
Clamp	V _{IK}	I _{IK} = -5 mA	—	—	-1.5	V
Input Current						
High, V _{IH} =2.4 V	I _{IH}	V _{CC} =5.5 V	—	—	80	μA
High, V _{IH} =5.5 V	I _{IH}	V _{CC} =5.5 V	—	—	400	μA
Low	I _{IL}	V _{CC} =5.5 V, V _{IL} =0.4 V	—	—	-0.98	mA
Output Current						
Short-Circuit	I _{OS}	V _{CC} =5.5 V, V _{OL} =0.0 V	-20	—	-75	mA
Power Supply Current	I _{CC}	V _{CC} =5.5 V	—	—	65	mA

Timing CharacteristicsV_{CC}=5.0 V, T_J=25 °C

Parameter	MTTL Family			Unit
	41FL Device			
	Min	Typ	Max	
Propagation Delays				
C0 to any Σ				
t _{PHL}	—	—	35	ns
t _{PLH}	—	—	40	ns
Ax or Bx to Σ				
t _{PHL}	—	—	55	ns
t _{PLH}	—	—	43	ns
C0 to C4				
t _{PHL}	—	—	24	ns
t _{PLH}	—	—	24	ns
Ax or Bx to C4				
t _{PHL}	—	—	23	ns
t _{PLH}	—	—	30	ns
Transition Times				
t _{TLH}	—	—	36	ns
t _{THL}	—	—	12.5	ns

Maximum Ratings

Power supply voltage (V _{CC})	7.0 V
Input voltage (V _I)	5.5 V
Operating temperature range (T _J)	-25 to +125 °C
Storage temperature range (T _{stg})	-40 to +125 °C

Maximum ratings are defined as the limiting conditions that the user can apply to the device under all variations of circuit and environmental conditions. If any rating is exceeded, permanent damage to the device may result.

Bonding or soldering of the external leads of this device can be performed safely at temperatures up to 300 °C.