

Helping Customers Innovate, Improve & Grow



PX-702

Vectron offers a small footprint High Temperature Ceramic SMD Crystal Oscillator (PX-702) product platform for extreme environment applications. In addition to its wide operating temperature range, PX-702 HTXO is also ideal for high shock & vibration applications. PX-702 HTXO is also designed to exceed 3000g shock and 36g vibration levels of the demanding MIL-STD-883 requirements.

Vectron's vertical integration in the following technical areas ensures the ability to design and manufacture state of the art high temperature frequency control products:

- BAW & SAW Design & Fabrication to produce high quality resonators.
- RF Oscillator Circuit Design.
- Established 250°C High Temperature Electronics Packaging Expertise.
- Established 250°C High Temperature Electronics Assembly & Test Expertise.
- Environmental Screening.

Vectron's manufacturing processes, from quartz resonator fabrication to oscillator electronics assembly and test, are painstakingly controlled via ISO and SPC procedures. Vectron fabricates high temperature quartz resonators using proprietary manufacturing processes designed specifically for high temperature and harsh environment applications. In order to ensure high reliability in the field, critical electrode metallization and testing processes are conducted inside state-of-the-art Class 1K cleanrooms, while oscillator assembly is conducted in Class 10K cleanrooms. All high temperature oscillators are 100% tested before delivery.

Features

- **Continuous operating temperature range -55°C to 230°C**
- **1.8, 2.5, 3.3 or 5.0 Vdc operation**
- **Tight temperature stability**
- **Design for high shock & vibration to exceed 3000g shock & 36g vibration**
- **Output frequency 500KHz to 40MHz standard (see HT RTCXO datasheet for 32.768KHz requirements)**
- **Standard 5 x 7 x 1.8 mm SMD package**
- **Made in USA**

Applications

- Oil / Gas downhole tool
- Geophysical services
- High temperature industrial process control
- Extended temperature Military/Aerospace
- Avionics
- Engine control



Block Diagram

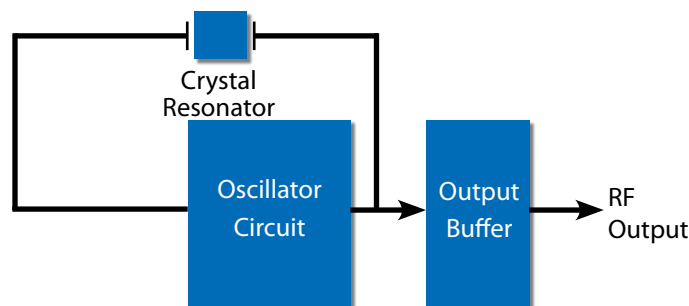

Performance Specifications

| Specification Parameters | Values | |
|--|--|--|
| Frequency Range | 500KHz to 50MHz Std (see HT RTCXO datasheet for 32.768KHz requirements) (Hi-Freq Design to 100MHz available, consult factory) | |
| Supply (Vdd) | +1.8Vdc ±5% (J) +2.5Vdc ±5% (H) | +3.3Vdc ±5% (E) +5.0Vdc ±5% (D) |
| Current | 3.5mA typical @ 7.5MHz, 3.3V (Consult factory for ultra low current requirements) 1mA typical @ 7.5MHz, 1.8V | |
| Level "0" & "1" | <0.4V / >Vdd - 0.5V | |
| Output | HCMOS Compatible (A) | |
| Rise & Fall Time | 1ns typical / 5ns Max | |
| Symmetry | 40/60% | |
| Operating Temperature | 0°C to +150°C (1) -20°C to +180°C (Z) -55°C to +180°C (Y) 0°C to +200°C (2) | -55°C to +200°C (5) 0°C to +230°C (3) -55°C to 230°C (6) (Consult factory for custom temp requirement up to +250°C) |
| Jitter (12kHz - 20MHz) | <0.5 ps Typical | |
| Phase Noise (typical @20MHz, HCMOS, 3.3V) | 10Hz -70 dBc/Hz 100Hz -110 dBc/Hz 1kHz -135 dBc/Hz 10kHz -150 dBc/Hz 100kHz -160 dBc/Hz 1MHz -160 dBc/Hz | |
| Temperature Stability | ±40ppm (J) ±100ppm (S) ±150ppm (U) | ±200ppm (V) ±250ppm (W) ±350ppm (Y) |
| Package Size | 5.0 x 7.0 x 1.8 mm Ceramic SMD | |
| Storage Temperature | -55°C to +125°C | |

| Environmental Compliance | | |
|--------------------------|---------------|---|
| Mechanical Shock | 3000g | MIL-STD-883, Method 2002.5, Condition C |
| Random Vibration | 36.6g | MIL-STD-883, Method 2026, Condition J |
| Sine Vibration | 30g | MIL-STD-202, Method 204, Condition G |
| Seal Test | Fine | MIL-STD-883 Method 1014 Condition A2 |
| Seal Test | Gross | MIL-STD-202 Method 112 Condition D |
| Temperature Cycling | 1000 Cycles | MIL-STD-883 Method 1010 Condition B |
| Acceleration | 5000g Y1 axis | MIL-STD-883 Method 2001 Condition A |

Physical Specifications and Marking

| Pin | Function |
|-----|--------------------------------------|
| 1 | Enable/Disable option |
| 2 | No Connection |
| 3 | Case & Electrical Ground |
| 4 | RF Output |
| 5 | No Connection |
| 6 | V _{CC} Power Supply Voltage |

Dimensions in (mm)

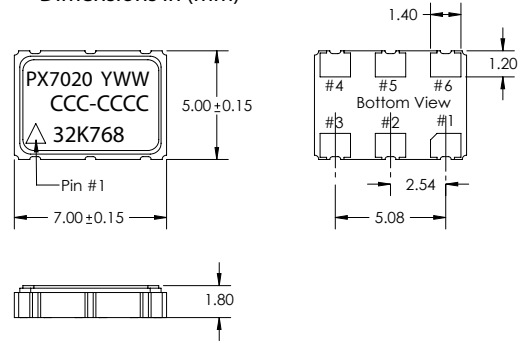

Pad Layout Pattern

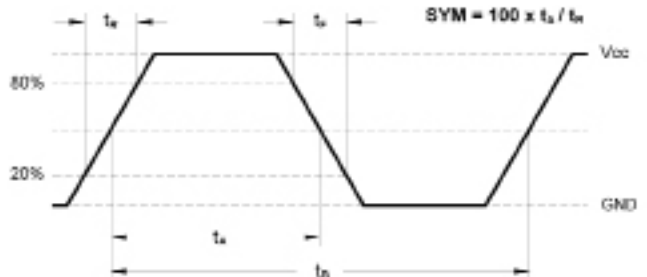
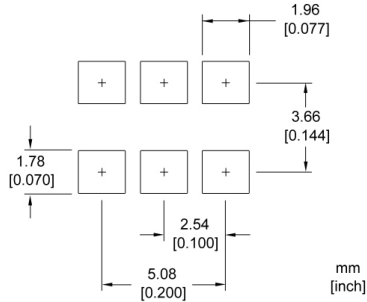

Test Circuit Diagram

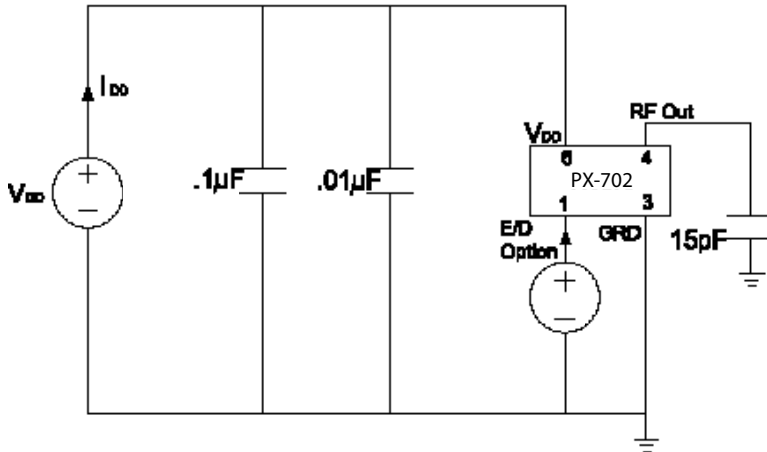

Frequency - Temperature Performance

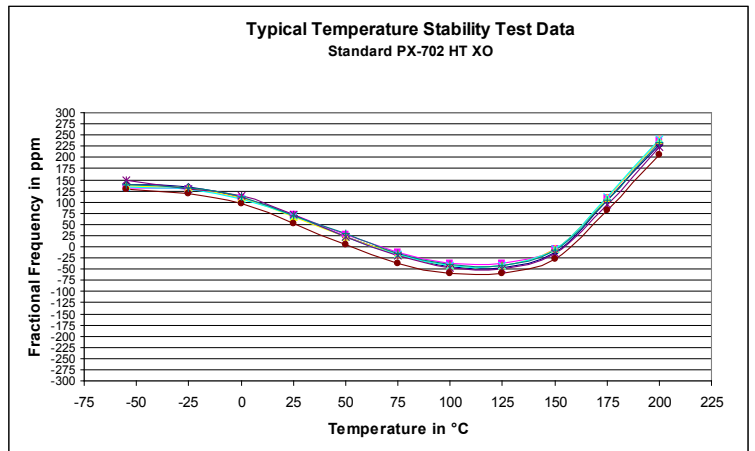
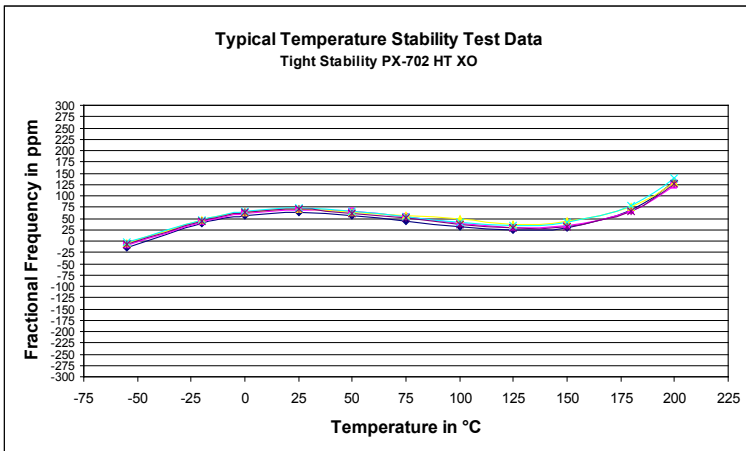

Start-Up Performance

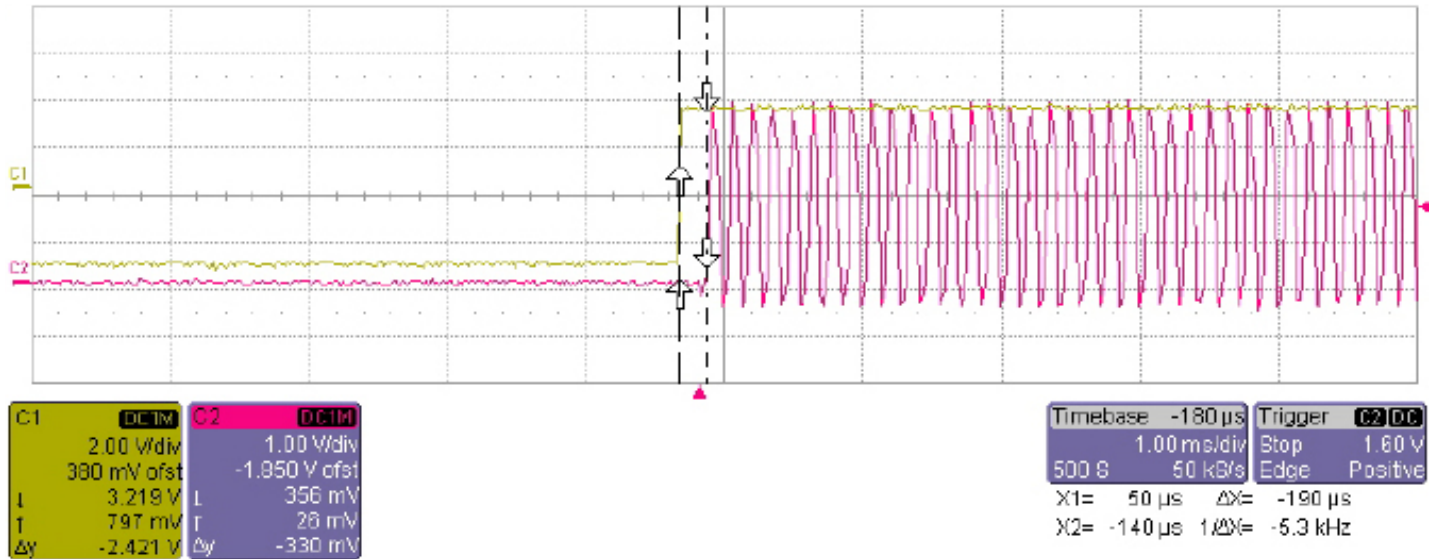

Phase Noise Performance

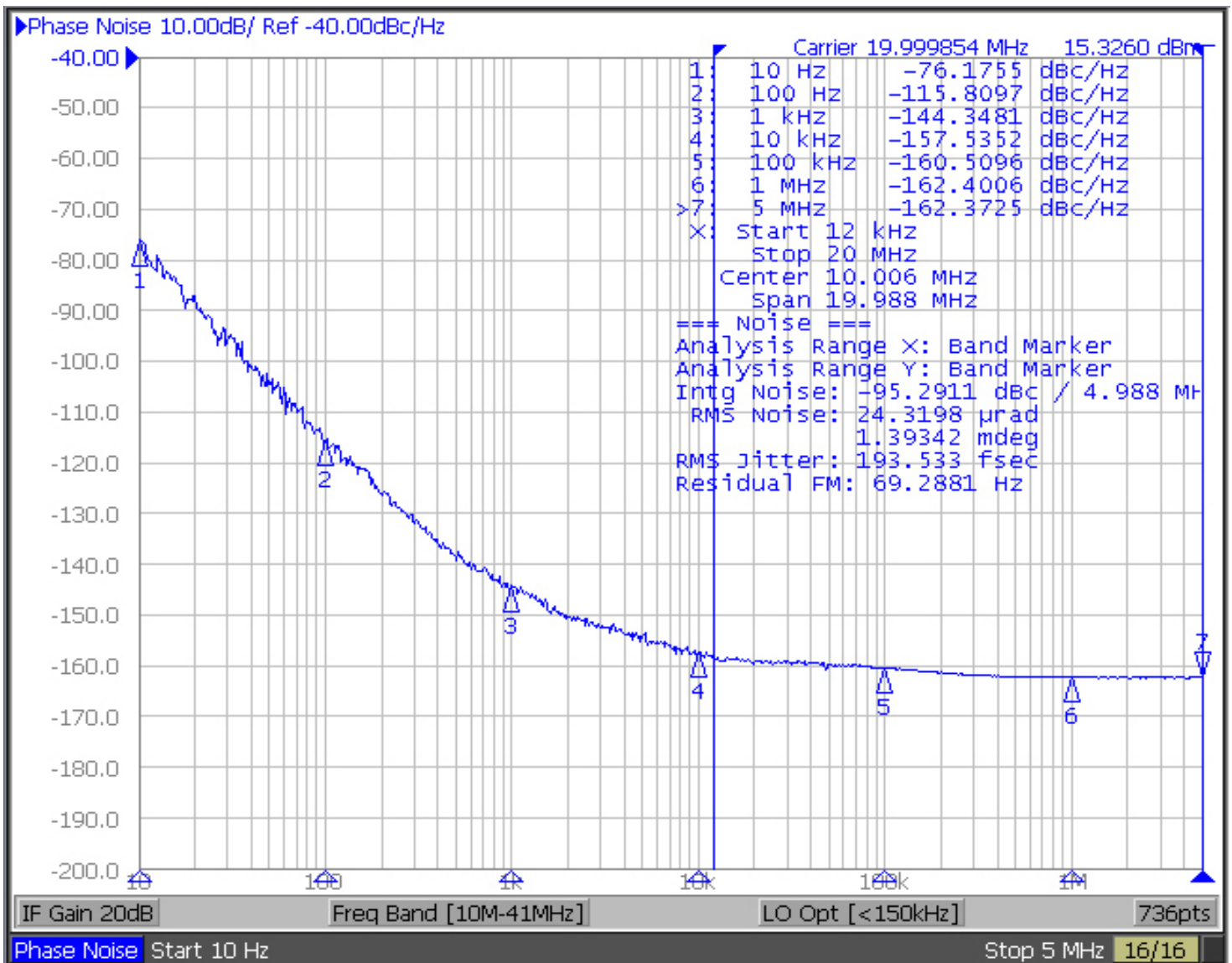

Standard Frequency List

| | | | | | | | |
|-------------|------------|-----------|-----------|-----------|-----------|-----------|-----------|
| 32.768kHz * | 512.000kHz | 1.000MHz | 1.024MHz | 2.000MHz | 2.048MHz | 3.686MHz | 4.000MHz |
| 4.096MHz | 5.000MHz | 7.3728MHz | 8.000MHz | 8.192MHz | 10.000MHz | 12.000MHz | 16.000MHz |
| 16.384MHz | 20.000MHz | 24.000MHz | 32.000MHz | 32.768MHz | 40.000MHz | 48.000MHz | |

* See HT RTCXO datasheet for 32.768KHz requirements

Ordering Information

PX - 702 0 - E A Y - W X X X - 20M0000000

Product Family
Crystal Oscillator

Package Type
702: 5x7 mm HTCC

Factory Use

Supply Voltage

- J: 1.8V ±5%
- H: 2.5V ±5%
- E: 3.3V ±5%
- D: 5.0V ±5%

Output

A: HCMOS/ACMOS

Frequency

Factory Use

Factory Use

Enable

A: Enable Hi, Tristate
X: No Enable

Temp Stability (PX)

- J: ± 40ppm
- S: ± 100ppm
- U: ± 150ppm
- V: ± 200ppm
- W: ± 250ppm
- Y: ± 350ppm

Temperature Range

- 1: 0°C to 150°C
- Z: -20°C to 180°C
- Y: -55°C to 180°C
- 2: 0°C to 200°C
- 5: -55°C to 200°C
- 3: 0°C to 230°C
- 6: -55°C to 230°C

Temperature Range and Stability Table

| Temp Range | Temp Stability | PX-702 |
|-------------------|----------------|-----------------|
| 1: 0°C to 150°C | J: ± 40ppm | Tight Stability |
| | S: ± 100ppm | Standard |
| | U: ± 150ppm | Standard |
| | W: ± 250ppm | Standard |
| Z: -20°C to 180°C | J: ± 40ppm | Tight Stability |
| | S: ± 100ppm | Tight Stability |
| | U: ± 150ppm | Standard |
| | W: ± 250ppm | Standard |
| Y: -55°C to 180°C | S: ± 100ppm | Tight Stability |
| | U: ± 150ppm | Standard |
| | W: ± 250ppm | Standard |
| 2: 0°C to 200°C | S: ± 100ppm | Tight Stability |
| | U: ± 150ppm | Tight Stability |
| | V: ± 200ppm | Standard |
| | W: ± 250ppm | Standard |
| 5: -55°C to 200°C | S: ± 100ppm | Tight Stability |
| | U: ± 150ppm | Tight Stability |
| | V: ± 200ppm | Standard |
| | W: ± 250ppm | Standard |
| 3: 0°C to 230°C | V: ± 200ppm | Tight Stability |
| | W: ± 250ppm | Tight Stability |
| | Y: ± 350ppm | Standard |
| 6: -55°C to 230°C | V: ± 200ppm | Tight Stability |
| | W: ± 250ppm | Tight Stability |
| | Y: ± 350ppm | Standard |

**Contact factory for custom requirements*

This page is purposely left blank

For Additional Information, Please Contact

USA:

Vectron International
267 Lowell Road, Unit 102
Hudson, NH 03051
Tel: 1.888.328.7661
Fax: 1.888.329.8328

Europe:

Vectron International
Landstrasse, D-74924
Neckarbischofsheim, Germany
Tel: +49 (0) 3328.4784.17
Fax: +49 (0) 3328.4784.30

Asia:

Vectron International
68 Yin Cheng Road(C), 22nd Floor
One LuJiaZui
Pudong, Shanghai 200120, China
Tel: 86.21.6194.6886
Fax: 86.21.6194.6699

Disclaimer

Vectron International reserves the right to make changes to the product(s) and or information contained herein without notice. No liability is assumed as a result of their use or application. No rights under any patent accompany the sale of any such product(s) or information.