

## Description

Q-Tech's surface mount 7 x 5 mm oscillator series consist of an IC 5Vdc, 3.3Vdc, 2.5Vdc, 1.8Vdc clock square wave generator and a miniature strip AT quartz crystal built in a low profile ceramic package with thru-hole, formed lead, or gull wing. This is the smallest package Q-Tech has ever offered for High Reliability applications with standard Hot Solder Dip finish per MIL-PRF 55310. The lead forming can provide a solution for many applications that require additional lead attachment from an outside subcontractor.

## Features

- Made in the USA
- Broad frequency range from 500kHz to 160MHz
- Small footprint
- Standard Hot Solder Dip finish Sn60
- LVHCMOS, HCMOS, and TTL compatible
- 5.0Vdc, 3.3Vdc, 2.5Vdc, 1.8Vdc supply
- Able to meet 36000G shock per ITOP 1-2-601
- Wide operating temperature range
- Tri-State Output (Option D)
- Hermetically sealed ceramic package
- Fundamental and 3rd Overtone designs
- Full or partial military screening tests available
- Tape and reel packaging
- RoHS compliant



## Applications

- Designed to meet today's requirements for low voltage applications
- High shock applications
- Gun launched munitions and systems
- Smart munitions
- Instrumentation
- Navigation
- Avionics
- Microprocessor clock

## Ordering Information

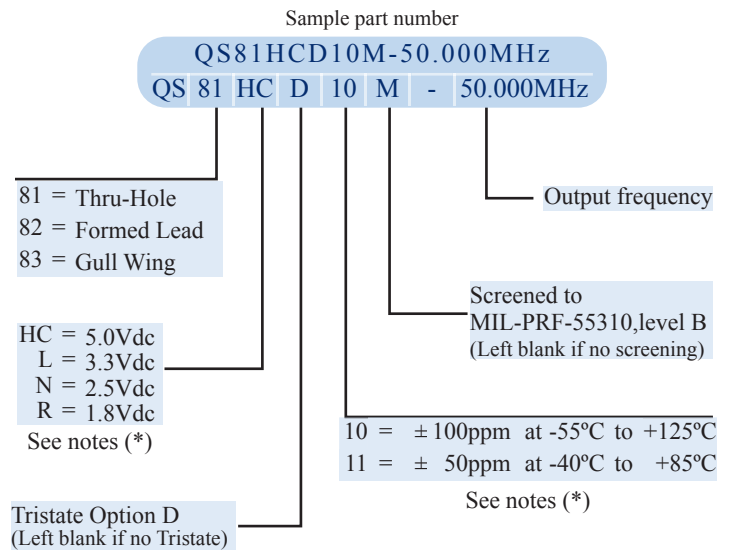

### (\*) Notes

- Supply voltage, frequency stability vs. temperature codes may not be available in all frequencies.
- For Non-Standard requirements, contact Q-Tech Corporation at Sales@Q-Tech.com

Hot Solder Dip Sn60 per MIL-PRF 55310 is standard on these packages  
Available for temperature up to +200°C with Q-Tech MCM number.

**Specifications subject to change without prior notice.**



**LOW PROFILE QS81, QS82, QS83**  
**MINIATURE SMD CRYSTAL OSCILLATORS**  
 1.8 to 5.0Vdc - 500kHz to 160MHz

**Electrical Characteristics**

Parameters	HC	L	N	R
Output frequency range (Fo)	500kHz — 50.000MHz	500kHz — 160.000MHz	500kHz — 133.000MHz	500kHz — 100.000MHz
Supply voltage (Vdd)	5.0Vdc ± 10%	3.3Vdc ± 10%	2.5Vdc ± 10%	1.8Vdc ± 10%
Maximum Applied Voltage (Vdd max.)	7.0Vdc	5.0Vdc		
Frequency stability (ΔF/ΔT)	See Option codes			
Operating temperature (Topr)	See Option codes			
Storage temperature (Tsto)	-62°C to + 125°C			
Operating supply current (Idd) (No Load)	20 mA max. - 500kHz ~ < 16MHz 25 mA max. - 16MHz ~ < 32MHz 35 mA max. - 32MHz ~ < 50MHz	6 mA max. - 500kHz ~ < 16MHz 10 mA max. - 16MHz ~ < 32MHz 20 mA max. - 32MHz ~ < 60MHz 30 mA max. - 60MHz ~ < 100MHz 40 mA max. - 100MHz ~ < 130MHz 50 mA max. - 130MHz ~ ≤ 160MHz	6 mA max. - 500kHz ~ < 40MHz 15 mA max. - 40MHz ~ < 60MHz 25 mA max. - 60MHz ~ < 85MHz 35 mA max. - 85MHz ~ ≤ 133MHz	4 mA max. - 500kHz ~ < 40MHz 10 mA max. - 40MHz ~ < 50MHz 20 mA max. - 50MHz ~ < 85MHz 25 mA max. - 85MHz ~ ≤ 100MHz
Symmetry (50% of output waveform or 1.4Vdc for TTL)	45/55% max. - 500kHz ~ < 21MHz 40/60% max. - 21 ~ ≤ 50MHz	45/55% max. - 500kHz ~ < 21MHz 40/60% max. - 21 ~ ≤ 160MHz	45/55% max. - 500kHz ~ < 21MHz 40/60% max. - 21 ~ ≤ 133MHz	45/55% max. - 500kHz ~ < 21MHz 40/60% max. - 21 ~ ≤ 100MHz
Rise and Fall times (with typical load)	6ns max. - Fo < 30MHz 3ns max. - Fo ≥ 30 - 50MHz (between 10% to 90%)	6ns max. - 500kHz ~ < 40MHz 3ns max. - 40 ~ ≤ 160MHz (between 10% to 90%)	5ns max. - 500kHz ~ < 40MHz 3ns max. - 40 ~ ≤ 133MHz (between 10% to 90%)	5ns max. - 500kHz ~ < 40MHz 3ns max. - 40 ~ ≤ 100MHz (between 10% to 90%)
Output Load	<b>15pF // 10kohms</b> 50pF max. or 10TTL	<b>15pF // 10kohms</b> (30pF max. for F ≤ 50MHz)	<b>15pF // 10kohms</b>	
Start-up time (Tstup)	10ms max.			
Output voltage (Voh/Vol)	0.9 x Vdd min.; 0.1 x Vdd max.	0.9 x Vdd min.; 0.1 x Vdd max.		
Output Current (Ioh/Iol)	± 24mA max.	± 4mA max.		
Enable/Disable Tristate function Pin 1	VIH ≥ 2.2V Oscillation; VIL ≤ 0.8V High Impedance		VIH ≥ 0.7 x Vdd Oscillation; VIL ≤ 0.3 x Vdd High Impedance	
Jitter RMS 1σ (at 25°C)	8ps typ. - < 40MHz 5ps typ. - ≥ 40MHz	15ps typ. - < 40MHz 8ps typ. - ≥ 40MHz		
Aging (at 70°C)	± 5ppm max. first year / ± 2ppm max. per year thereafter			

## Package Outlines

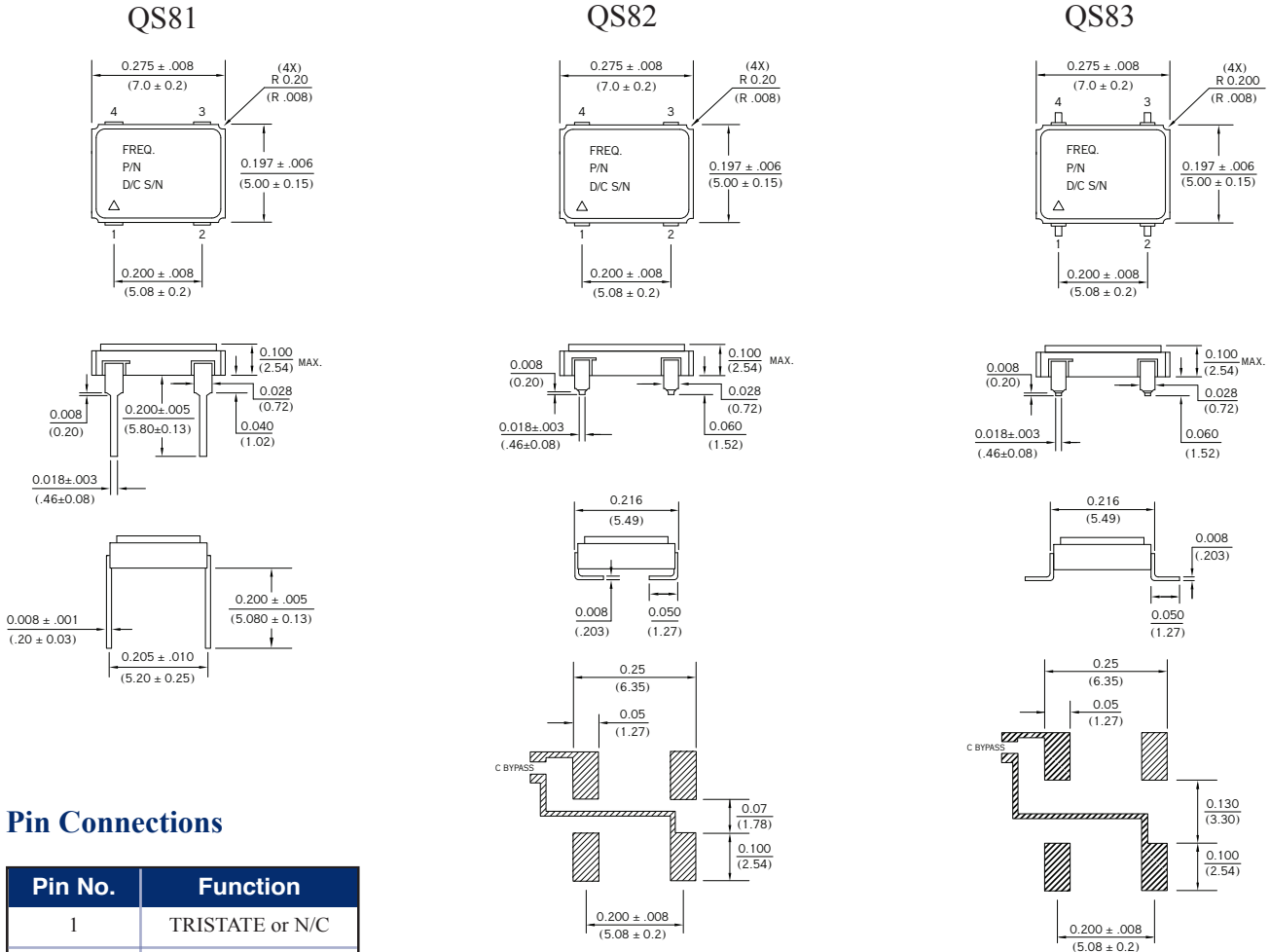

## Pin Connections

Pin No.	Function
1	TRISTATE or N/C
2	GND/CASE
3	OUTPUT
4	VDD

An external bypass capacitor 0.01μF is required between Vdd and GND

Dimensions are in inches (mm)

## Marking Information

Line 1: XX.XXXX (Frequency in MHz)  
Line 2: P/N (QS81L9M)  
Line 3: Dot + D/C and S/N

## Package Information

- Package material: 90% AL<sub>2</sub>O<sub>3</sub>
- Weight: .15g typ., 2g max.
- Lead material: Kovar
- Lead finish: Nickel Underplate: 100μ ~ 250μ inches  
Gold Plated: 50μ ~ 80μ inches  
Hot Solder Dip Sn60 Finish

### Output Waveform (Typical)

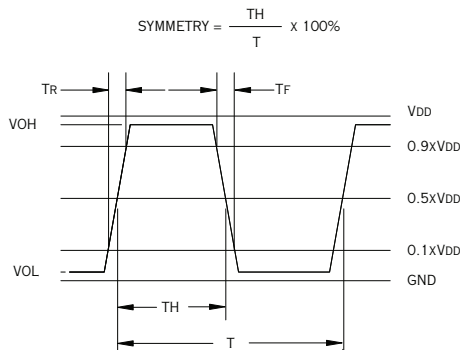

### Frequency vs. Temperature Curve

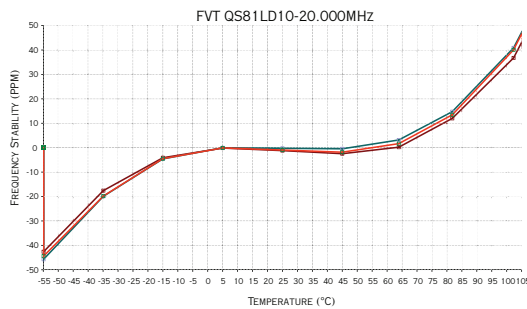

### Reflow Profile

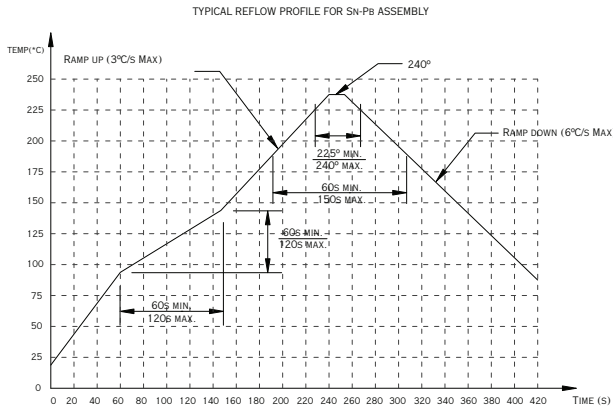

### Environmental and Mechanical Specifications

Environmental Test	Test Conditions
Temperature cycling	MIL-STD-883, Method 1010, Cond. B
Constant acceleration	MIL-STD-883, Method 2001, Cond. A, Y1
Seal Gross Leak	MIL-STD-883, Method 1014, Cond. C
Vibration sinusoidal	MIL-STD-202, Method 204, Cond. D
Shock, non operating	MIL-STD-202, Method 213, Cond. I
Resistance to solder heat	MIL-STD-202, Method 210, Cond. B
Resistance to solvents	MIL-STD-202, Method 215
Solderability	MIL-STD-202, Method 208
ESD Classification	MIL-STD-883, Method 3015, Class 1 HBM 0 to 1,999V
Moisture Sensitivity Level	J-STD-020, MSL=1

### Test Circuit

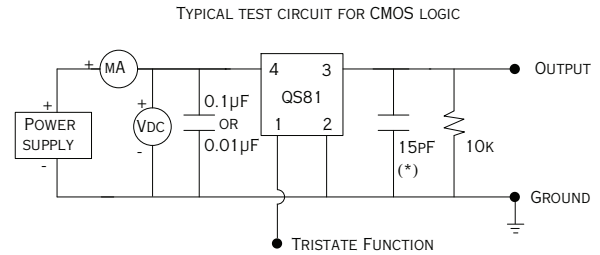

(\* CL INCLUDES PROBE AND JIG CAPACITANCE)

The Tristate function on pin 1 has a built-in pull-up resistor so it can be left floating or tied to Vdd without deteriorating the electrical performance.

### Embossed Tape and Reel Information for QS82

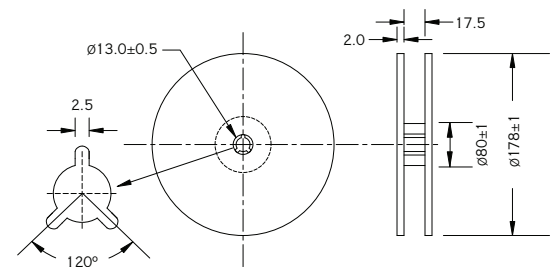
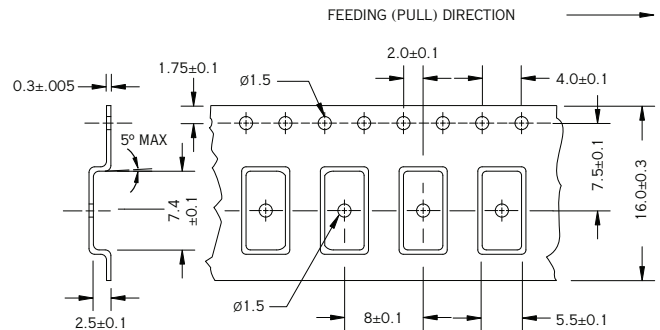

Dimensions are in mm. Tape is compliant to EIA-481-A.

Reel size (Diameter in mm)	Qty per reel (pcs)
178	1,000