

## **Rochester Electronics Manufactured Components**

Rochester branded components are manufactured using either die/wafers purchased from the original suppliers or Rochester wafers recreated from the original IP. All recreations are done with the approval of the OCM.

Parts are tested using original factory test programs or Rochester developed test solutions to guarantee product meets or exceed the OCM data sheet.

## **Quality Overview**

- ISO-9001
- AS9120 certification
- Qualified Manufacturers List (QML) MIL-PRF-35835
  - Class Q Military
  - Class V Space Level
- Qualified Suppliers List of Distributors (QSLD)
  - Rochester is a critical supplier to DLA and meets all industry and DLA standards.

Rochester Electronics, LLC is committed to supplying products that satisfy customer expectations for quality and are equal to those originally supplied by industry manufacturers.

The original manufacturer's datasheet accompanying this document reflects the performance and specifications of the Rochester manufactured version of this device. Rochester Electronics guarantees the performance of its semiconductor products to the original OEM specifications. 'Typical' values are for reference purposes only. Certain minimum or maximum ratings may be based on product characterization, design, simulation, or sample testing.

# Programmable Skew Clock Buffer

## Features

- All Output Pair Skew <100 ps Typical (250 ps maximum)
- 3.75 MHz to 80 MHz Output Operation
- User Selectable Output Functions
  - Selectable Skew to 18 ns
  - Inverted and Non-inverted
  - Operation at 1/2 and 1/4 Input Frequency
  - Operation at 2x and 4x Input Frequency (input as low as 3.75 MHz)
- Zero Input to Output Delay
- 50% Duty Cycle Outputs
- Outputs drive 50Ω terminated lines
- Low Operating Current
- 32-pin PLCC/LCC Package
- Jitter <200 ps Peak-to-peak (< 25 ps RMS)

## Functional Description

The CY7B991 and CY7B992 Programmable Skew Clock Buffers (PSCB) offer user selectable control over system clock functions. These multiple output clock drivers provide the system integrator with functions necessary to optimize the timing of high performance computer systems. Each of the eight individual drivers, arranged in four pairs of user controllable outputs, can drive terminated transmission lines with impedances as low as 50Ω. They can deliver minimal and specified output skews and full swing logic levels (CY7B991 TTL or CY7B992 CMOS).

Each output is hardwired to one of the nine delay or function configurations. Delay increments of 0.7 to 1.5 ns are determined by the operating frequency with outputs that skew up to ±6 time units from their nominal “zero” skew position. The completely integrated PLL allows cancellation of external load and transmission line delay effects. When this “zero delay” capability of the PSCB is combined with the selectable output skew functions, you can create output-to-output delays of up to ±12 time units.

Divide-by-two and divide-by-four output functions are provided for additional flexibility in designing complex clock systems. When combined with the internal PLL, these divide functions enable distribution of a low frequency clock that are multiplied by two or four at the clock destination. This facility minimizes clock distribution difficulty, allowing maximum system clock speed and flexibility.

## Logic Block Diagram

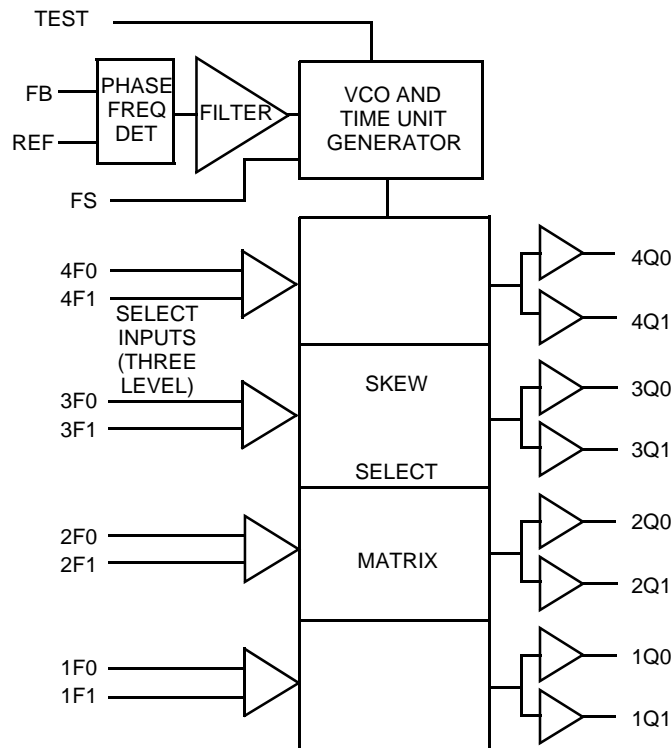

## Pinouts

Figure 1. Pin Configuration – 32-Pin PLCC/LCC Package

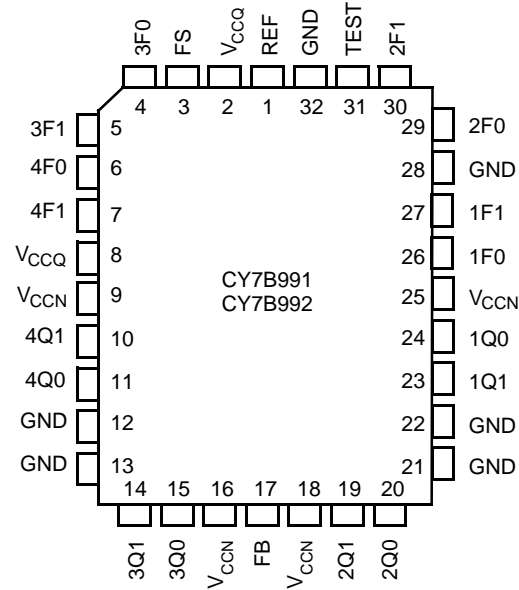

Table 1. Pin Definition

Signal Name	IO	Description
REF	I	Reference frequency input. This input supplies the frequency and timing against which all functional variations are measured.
FB	I	PLL feedback input (typically connected to one of the eight outputs).
FS	I	Three level frequency range select. See <a href="#">Table 2</a> .
1F0, 1F1	I	Three level function select inputs for output pair 1 (1Q0, 1Q1). See <a href="#">Table 3</a> .
2F0, 2F1	I	Three level function select inputs for output pair 2 (2Q0, 2Q1). See <a href="#">Table 3</a> .
3F0, 3F1	I	Three level function select inputs for output pair 3 (3Q0, 3Q1). See <a href="#">Table 3</a> .
4F0, 4F1	I	Three level function select inputs for output pair 4 (4Q0, 4Q1). See <a href="#">Table 3</a> .
TEST	I	Three level select. See "Test Mode" on page 4 under the "Block Diagram Description" on page 3.
1Q0, 1Q1	O	Output pair 1. See <a href="#">Table 3</a> .
2Q0, 2Q1	O	Output pair 2. See <a href="#">Table 3</a> .
3Q0, 3Q1	O	Output pair 3. See <a href="#">Table 3</a> .
4Q0, 4Q1	O	Output pair 4. See <a href="#">Table 3</a> .
VCCN	PWR	Power supply for output drivers.
VCCQ	PWR	Power supply for internal circuitry.
GND	PWR	Ground.

## Block Diagram Description

### Phase Frequency Detector and Filter

The Phase Frequency Detector and Filter blocks accept inputs from the reference frequency (REF) input and the feedback (FB) input and generate correction information to control the frequency of the Voltage Controlled Oscillator (VCO). These blocks, along with the VCO, form a Phase Locked Loop (PLL) that tracks the incoming REF signal.

### VCO and Time Unit Generator

The VCO accepts analog control inputs from the PLL filter block. It generates a frequency used by the time unit generator to create discrete time units that are selected in the skew select matrix. The operational range of the VCO is determined by the FS control pin. The time unit ( $t_U$ ) is determined by the operating frequency of the device and the level of the FS pin as shown in [Table 2](#).

**Table 2. Frequency Range Select and  $t_U$  Calculation<sup>[1]</sup>**

FS <sup>[2, 3]</sup>	f <sub>NOM</sub> (MHz)		$t_U = \frac{1}{f_{NOM} \times N}$ where N =	Approximate Frequency (MHz) At Which $t_U = 1.0$ ns
	Min	Max		
LOW	15	30	44	22.7
MID	25	50	26	38.5
HIGH	40	80	16	62.5

### Skew Select Matrix

The skew select matrix contains four independent sections. Each section has two low skew, high fanout drivers (xQ0, xQ1), and two corresponding three level function select (xF0, xF1) inputs. [Table 3](#) shows the nine possible output functions for each section as determined by the function select inputs. All times are measured with respect to the REF input assuming that the output connected to the FB input has 0 $t_U$  selected.

**Table 3. Programmable Skew Configurations<sup>[1]</sup>**

Function Selects		Output Functions		
1F1, 2F1, 3F1, 4F1	1F0, 2F0, 3F0, 4F0	1Q0, 1Q1, 2Q0, 2Q1	3Q0, 3Q1	4Q0, 4Q1
LOW	LOW	-4 $t_U$	Divide by 2	Divide by 2
LOW	MID	-3 $t_U$	-6 $t_U$	-6 $t_U$
LOW	HIGH	-2 $t_U$	-4 $t_U$	-4 $t_U$
MID	LOW	-1 $t_U$	-2 $t_U$	-2 $t_U$
MID	MID	0 $t_U$	0 $t_U$	0 $t_U$
MID	HIGH	+1 $t_U$	+2 $t_U$	+2 $t_U$
HIGH	LOW	+2 $t_U$	+4 $t_U$	+4 $t_U$
HIGH	MID	+3 $t_U$	+6 $t_U$	+6 $t_U$
HIGH	HIGH	+4 $t_U$	Divide by 4	Inverted

#### Notes

- For all tri-state inputs, HIGH indicates a connection to VCC, LOW indicates a connection to GND, and MID indicates an open connection. Internal termination circuitry holds an unconnected input to VCC/2.
- The level is set on FS is determined by the "normal" operating frequency (f<sub>NOM</sub>) of the VCO and Time Unit Generator (see [Logic Block Diagram](#)). Nominal frequency (f<sub>NOM</sub>) always appears at 1Q0 and the other outputs when they are operated in their undivided modes (see [Table 3](#)). The frequency appearing at the REF and FB inputs are f<sub>NOM</sub> when the output connected to FB is undivided. The frequency of the REF and FB inputs are f<sub>NOM</sub>/2 or f<sub>NOM</sub>/4 when the part is configured for a frequency multiplication by using a divided output as the FB input.
- When the FS pin is selected HIGH, the REF input must not transition upon power up until VCC has reached 4.3V.

Figure 2 shows the typical outputs with FB connected to a zero skew output.<sup>[4]</sup>

Figure 2. Typical Outputs with FB Connected to a Zero-Skew Output

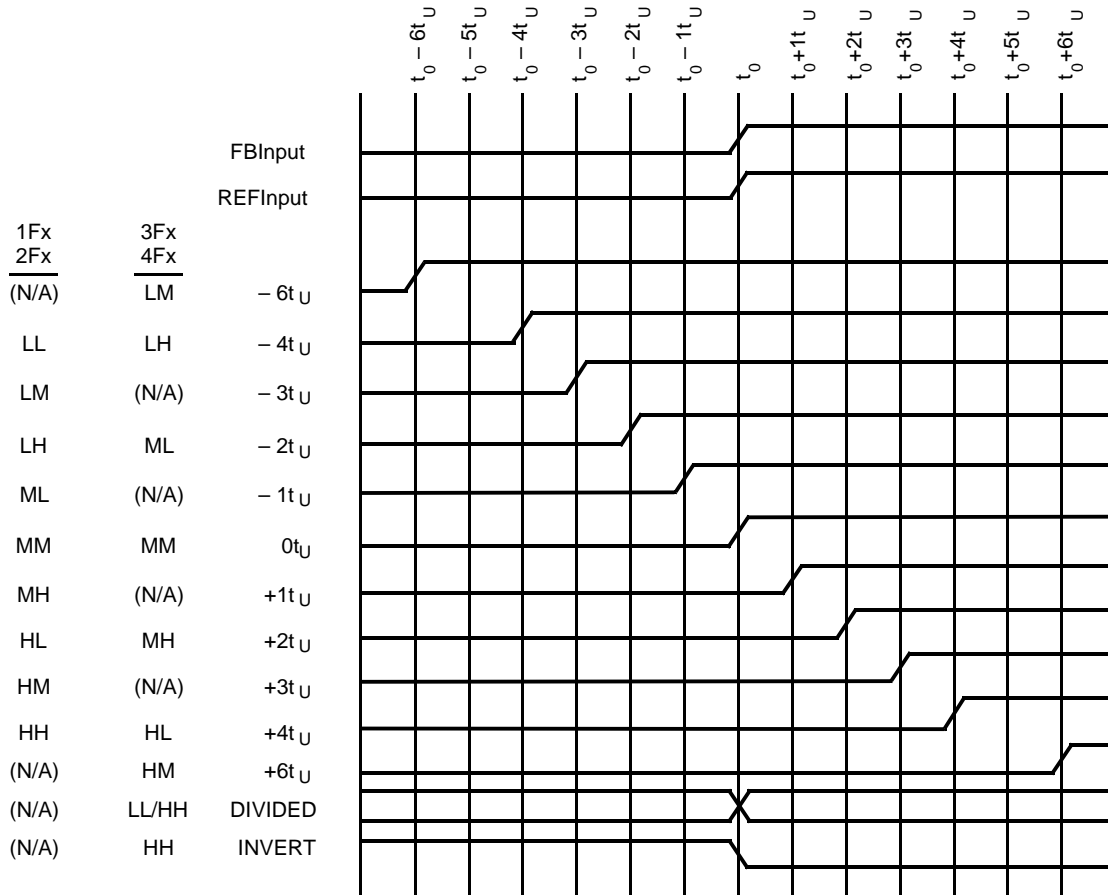

## Test Mode

The TEST input is a three level input. In normal system operation, this pin is connected to ground, enabling the CY7B991 or CY7B992 to operate as explained in “Skew Select Matrix” on page 3. For testing purposes, any of the three level inputs can have a removable jumper to ground, or be tied LOW through a 100Ω resistor. This enables an external tester to change the state of these pins.

If the TEST input is forced to its MID or HIGH state, the device operates with its internal phase locked loop disconnected, and input levels supplied to REF directly controls all outputs. Relative output to output functions are the same as in normal mode.

In contrast with normal operation (TEST tied LOW), all outputs function based only on the connection of their own function selects inputs (xF0 and xF1) and the waveform characteristics of the REF input.

### Note

4. FB connected to an output selected for “zero” skew (i.e., xF1 = xF0 = MID).

### Maximum Ratings

Exceeding maximum ratings may shorten the useful life of the device. User guidelines are not tested.

- Storage Temperature ..... -65°C to +150°C
- Ambient Temperature with  
Power Applied ..... -55°C to +125°C
- Supply Voltage to Ground Potential..... -0.5V to +7.0V
- DC Input Voltage ..... -0.5V to +7.0V
- Output Current into Outputs (LOW)..... 64 mA
- Static Discharge Voltage..... >2001V  
(MIL-STD-883, Method 3015)
- Latch Up Current ..... >200 mA

### Operating Range

Range	Ambient Temperature	V <sub>CC</sub>
Commercial	0°C to +70°C	5V ± 10%
Industrial	-40°C to +85°C	5V ± 10%
Military <sup>[5]</sup>	-55°C to +125°C	5V ± 10%
Military <sup>[5]</sup>	-55°C to +125°C	5V ± 10%

**Note**

5. Indicates case temperature.

## Electrical Characteristics

Over the Operating Range<sup>[6]</sup>

Parameter	Description	Test Conditions	CY7B991		CY7B992		Unit
			Min	Max	Min	Max	
V <sub>OH</sub>	Output HIGH Voltage	V <sub>CC</sub> = Min, I <sub>OH</sub> = -16 mA	2.4				V
		V <sub>CC</sub> = Min, I <sub>OH</sub> = -40 mA			V <sub>CC</sub> - 0.75		
V <sub>OL</sub>	Output LOW Voltage	V <sub>CC</sub> = Min, I <sub>OL</sub> = 46 mA		0.45			V
		V <sub>CC</sub> = Min, I <sub>OL</sub> = 46 mA				0.45	
V <sub>IH</sub>	Input HIGH Voltage (REF and FB inputs only)		2.0	V <sub>CC</sub>	V <sub>CC</sub> - 1.35	V <sub>CC</sub>	V
V <sub>IL</sub>	Input LOW Voltage (REF and FB inputs only)		-0.5	0.8	-0.5	1.35	V
V <sub>IHH</sub>	Three Level Input HIGH Voltage (Test, FS, xFn) <sup>[10]</sup>	Min ≤ V <sub>CC</sub> ≤ Max	V <sub>CC</sub> - 0.85	V <sub>CC</sub>	V <sub>CC</sub> - 0.85	V <sub>CC</sub>	V
V <sub>IMM</sub>	Three Level Input MID Voltage (Test, FS, xFn) <sup>[10]</sup>	Min ≤ V <sub>CC</sub> ≤ Max	V <sub>CC</sub> /2 - 500 mV	V <sub>CC</sub> /2 + 500 mV	V <sub>CC</sub> /2 - 500 mV	V <sub>CC</sub> /2 + 500 mV	V
V <sub>ILL</sub>	Three Level Input LOW Voltage (Test, FS, xFn) <sup>[10]</sup>	Min ≤ V <sub>CC</sub> ≤ Maximum	0.0	0.85	0.0	0.85	V
I <sub>IH</sub>	Input HIGH Leakage Current (REF and FB inputs only)	V <sub>CC</sub> = Max, V <sub>IN</sub> = Max.		10		10	μA
I <sub>IL</sub>	Input LOW Leakage Current (REF and FB inputs only)	V <sub>CC</sub> = Max, V <sub>IN</sub> = 0.4V	-500		-500		μA
I <sub>IHH</sub>	Input HIGH Current (Test, FS, xFn)	V <sub>IN</sub> = V <sub>CC</sub>		200		200	μA
I <sub>IMM</sub>	Input MID Current (Test, FS, xFn)	V <sub>IN</sub> = V <sub>CC</sub> /2	-50	50	-50	50	μA
I <sub>ILL</sub>	Input LOW Current (Test, FS, xFn)	V <sub>IN</sub> = GND		-200		-200	μA
I <sub>OS</sub>	Output Short Circuit Current <sup>[8]</sup>	V <sub>CC</sub> = Max, V <sub>OUT</sub> = GND (25°C only)		-250		N/A	mA
I <sub>CCQ</sub>	Operating Current Used by Internal Circuitry	V <sub>CCN</sub> = V <sub>CCQ</sub> = Max, All Input Selects Open	Com'l	85		85	mA
			Mil/Ind	90		90	
I <sub>CCN</sub>	Output Buffer Current per Output Pair <sup>[9]</sup>	V <sub>CCN</sub> = V <sub>CCQ</sub> = Max, I <sub>OUT</sub> = 0 mA Input Selects Open, f <sub>MAX</sub>		14		19	mA
PD	Power Dissipation per Output Pair <sup>[10]</sup>	V <sub>CCN</sub> = V <sub>CCQ</sub> = Max, I <sub>OUT</sub> = 0 mA Input Selects Open, f <sub>MAX</sub>		78		104 <sup>[11]</sup>	mW

### Notes

- For more information see "Group A Subgroup Testing" on page 17.
- These inputs are normally wired to V<sub>CC</sub>, GND, or left unconnected (actual threshold voltages vary as a percentage of V<sub>CC</sub>). Internal termination resistors hold unconnected inputs at V<sub>CC</sub>/2. If these inputs are switched, the function and timing of the outputs may glitch and the PLL may require an additional t<sub>LOCK</sub> time before all datasheet limits are achieved.
- CY7B991 must be tested one output at a time, output shorted for less than one second, less than 10% duty cycle. Room temperature only. CY7B992 outputs must not be shorted to GND. Doing so may cause permanent damage.
- Total output current per output pairs approximated by the following expression that includes device current plus load current:  
 CY7B991: I<sub>CCN</sub> = [(4 + 0.11F) + [(835 - 3F)/Z] + (.0022FC)]N x 1.1  
 CY7B992: I<sub>CCN</sub> = [(3.5 + 0.17F) + [(1160 - 2.8F)/Z] + (.0025FC)]N x 1.1  
 Where  
 F = frequency in MHz; C = capacitive load in pF; Z = line impedance in ohms; N = number of loaded outputs; 0, 1, or 2; FC = F < C.
- Total power dissipation per output pair can be approximated by the following expression that includes device power dissipation plus power dissipation due to the load circuit:  
 CY7B991: PD = [(22 + 0.61F) + [(1550 - 2.7F)/Z] + (.0125FC)]N x 1.1  
 CY7B992: PD = [(19.25 + 0.94F) + [(700 + 6F)/Z] + (.017FC)]N x 1.1  
 See note 9 for variable definition.
- Applies to REF and FB inputs only. Tested initially and after any design or process changes that may affect these parameters.

## Capacitance

CMOS output buffer current and power dissipation specified at 50 MHz reference frequency.

Parameter	Description	Test Conditions	Max	Unit
$C_{IN}$	Input Capacitance	$T_A = 25^\circ\text{C}$ , $f = 1\text{ MHz}$ , $V_{CC} = 5.0\text{V}$	10	pF

**Figure 3. AC Test Loads and Waveforms**

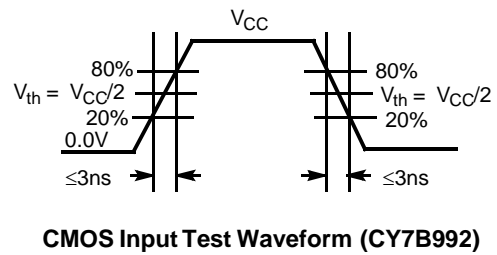
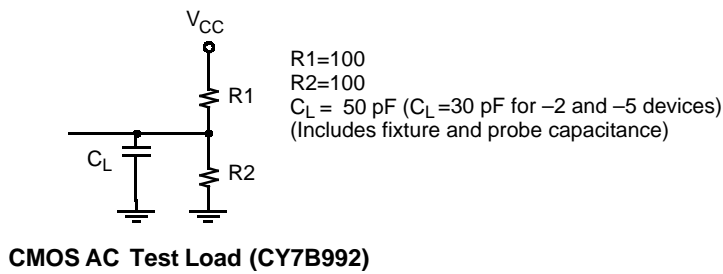
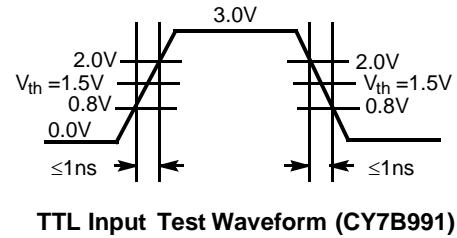
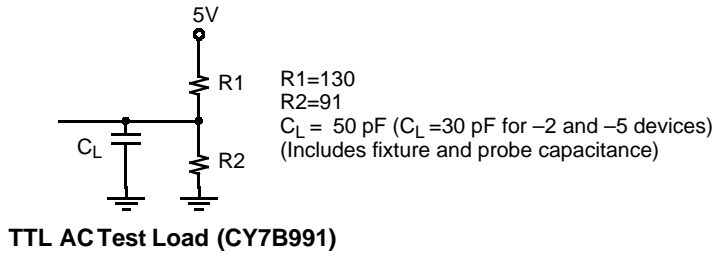

## Switching Characteristics

Over the Operating Range<sup>[2, 13]</sup>

Parameter	Description		CY7B991-2 <sup>[14]</sup>			CY7B992-2 <sup>[14]</sup>			Unit
			Min	Typ	Max	Min	Typ	Max	
f <sub>NOM</sub>	Operating Clock Frequency in MHz	FS = LOW <sup>[1, 2]</sup>	15		30	15		30	MHz
		FS = MID <sup>[1, 2]</sup>	25		50	25		50	
		FS = HIGH <sup>[1, 2, 3]</sup>	40		80	40		80 <sup>[15]</sup>	
t <sub>RPWH</sub>	REF Pulse Width HIGH		5.0			5.0			ns
t <sub>RPWL</sub>	REF Pulse Width LOW		5.0			5.0			ns
t <sub>U</sub>	Programmable Skew Unit		See Table 2						
t <sub>SKEWPR</sub>	Zero Output Matched-Pair Skew (XQ0, XQ1) <sup>[16, 17]</sup>			0.05	0.20		0.05	0.20	ns
t <sub>SKEW0</sub>	Zero Output Skew (All Outputs) <sup>[16, 18, 19]</sup>			0.1	0.25		0.1	0.25	ns
t <sub>SKEW1</sub>	Output Skew (Rise-Rise, Fall-Fall, Same Class Outputs) <sup>[16, 19]</sup>			0.25	0.5		0.25	0.5	ns
t <sub>SKEW2</sub>	Output Skew (Rise-Fall, Nominal-Inverted, Divided-Divided) <sup>[16, 19]</sup>			0.3	0.5		0.3	0.5	ns
t <sub>SKEW3</sub>	Output Skew (Rise-Rise, Fall-Fall, Different Class Outputs) <sup>[16, 19]</sup>			0.25	0.5		0.25	0.5	ns
t <sub>SKEW4</sub>	Output Skew (Rise-Fall, Nominal-Divided, Divided-Inverted) <sup>[16, 19]</sup>			0.5	0.9		0.5	0.7	ns
t <sub>DEV</sub>	Device-to-Device Skew <sup>[14, 21]</sup>				0.75			0.75	ns
t <sub>PD</sub>	Propagation Delay, REF Rise to FB Rise		-0.25	0.0	+0.25	-0.25	0.0	+0.25	ns
t <sub>ODCV</sub>	Output Duty Cycle Variation <sup>[22]</sup>		-0.65	0.0	+0.65	-0.5	0.0	+0.5	ns
t <sub>PWH</sub>	Output HIGH Time Deviation from 50% <sup>[23, 24]</sup>				2.0			3.0	ns
t <sub>PWL</sub>	Output LOW Time Deviation from 50% <sup>[23, 24]</sup>				1.5			3.0	ns
t <sub>ORISE</sub>	Output Rise Time <sup>[23, 25]</sup>		0.15	1.0	1.2	0.5	2.0	2.5	ns
t <sub>OFALL</sub>	Output Fall Time <sup>[23, 25]</sup>		0.15	1.0	1.2	0.5	2.0	2.5	ns
t <sub>LOCK</sub>	PLL Lock Time <sup>[26]</sup>				0.5			0.5	ms
t <sub>JR</sub>	Cycle-to-Cycle Output Jitter	RMS <sup>[14]</sup>			25			25	ps
		Peak-to-Peak <sup>[14]</sup>			200			200	ps

### Notes

12. CMOS output buffer current and power dissipation specified at 50 MHz reference frequency.
13. Test measurement levels for the CY7B991 are TTL levels (1.5V to 1.5V). Test measurement levels for the CY7B992 are CMOS levels (VCC/2 to VCC/2). Test conditions assume signal transition times of 2 ns or less and output loading as shown in the [AC Test Loads and Waveforms](#) unless otherwise specified.
14. Guaranteed by statistical correlation. Tested initially and after any design or process changes that affect these parameters.
15. Except as noted, all CY7B992-2 and -5 timing parameters are specified to 80 MHz with a 30 pF load.
16. SKEW is defined as the time between the earliest and the latest output transition among all outputs for which the same t<sub>U</sub> delay is selected when all are loaded with 50 pF and terminated with 50Ω to 2.06V (CY7B991) or VCC/2 (CY7B992).
17. t<sub>SKEWPR</sub> is defined as the skew between a pair of outputs (XQ0 and XQ1) when all eight outputs are selected for 0t<sub>U</sub>.
18. t<sub>SKEW0</sub> is defined as the skew between outputs when they are selected for 0t<sub>U</sub>. Other outputs are divided or inverted but not shifted.
19. CL=0 pF. For CL=30 pF, t<sub>SKEW0</sub>=0.35 ns.
20. There are three classes of outputs: Nominal (multiple of t<sub>U</sub> delay), Inverted (4Q0 and 4Q1 only with 4F0 = 4F1 = HIGH), and Divided (3Qx and 4Qx only in Divide-by-2 or Divide-by-4 mode).
21. t<sub>DEV</sub> is the output-to-output skew between any two devices operating under the same conditions (VCC ambient temperature, air flow, and so on.)
22. t<sub>ODCV</sub> is the deviation of the output from a 50% duty cycle. Output pulse width variations are included in t<sub>SKEW2</sub> and t<sub>SKEW4</sub> specifications.
23. Specified with outputs loaded with 30 pF for the CY7B99X-2 and -5 devices and 50 pF for the CY7B99X-7 devices. Devices are terminated through 50Ω to 2.06V (CY7B991) or VCC/2 (CY7B992).
24. t<sub>PWH</sub> is measured at 2.0V for the CY7B991 and 0.8 VCC for the CY7B992. t<sub>PWL</sub> is measured at 0.8V for the CY7B991 and 0.2 VCC for the CY7B992.
25. t<sub>ORISE</sub> and t<sub>OFALL</sub> measured between 0.8V and 2.0V for the CY7B991 or 0.8VCC and 0.2VCC for the CY7B992.
26. t<sub>LOCK</sub> is the time that is required before synchronization is achieved. This specification is valid only after VCC is stable and within normal operating limits. This parameter is measured from the application of a new signal or frequency at REF or FB until t<sub>PD</sub> is within specified limits.

## Switching Characteristics

Over the Operating Range<sup>[2, 13]</sup> (continued)

Parameter	Description		CY7B991-5			CY7B992-5			Unit
			Min	Typ	Max	Min	Typ	Max	
f <sub>NOM</sub>	Operating Clock Frequency in MHz	FS = LOW <sup>[1, 2]</sup>	15		30	15		30	MHz
		FS = MID <sup>[1, 2]</sup>	25		50	25		50	
		FS = HIGH <sup>[1, 2, 3]</sup>	40		80	40		80 <sup>[15]</sup>	
t <sub>RPWH</sub>	REF Pulse Width HIGH		5.0			5.0			ns
t <sub>RPWL</sub>	REF Pulse Width LOW		5.0			5.0			ns
t <sub>U</sub>	Programmable Skew Unit		See Table 2						
t <sub>SKIEWPR</sub>	Zero Output Matched-Pair Skew (XQ0, XQ1) <sup>[16, 17]</sup>			0.1	0.25		0.1	0.25	ns
t <sub>SKIEW0</sub>	Zero Output Skew (All Outputs) <sup>[16, 18]</sup>			0.25	0.5		0.25	0.5	ns
t <sub>SKIEW1</sub>	Output Skew (Rise-Rise, Fall-Fall, Same Class Outputs) <sup>[16, 19]</sup>			0.6	0.7		0.6	0.7	ns
t <sub>SKIEW2</sub>	Output Skew (Rise-Fall, Nominal-Inverted, Divided-Divided) <sup>[16, 19]</sup>			0.5	1.0		0.6	1.5	ns
t <sub>SKIEW3</sub>	Output Skew (Rise-Rise, Fall-Fall, Different Class Outputs) <sup>[16, 19]</sup>			0.5	0.7		0.5	0.7	ns
t <sub>SKIEW4</sub>	Output Skew (Rise-Fall, Nominal-Divided, Divided-Inverted) <sup>[16, 19]</sup>			0.5	1.0		0.6	1.7	ns
t <sub>DEV</sub>	Device-to-Device Skew <sup>[14, 21]</sup>				1.25			1.25	ns
t <sub>PD</sub>	Propagation Delay, REF Rise to FB Rise		-0.5	0.0	+0.5	-0.5	0.0	+0.5	ns
t <sub>ODCV</sub>	Output Duty Cycle Variation <sup>[22]</sup>		-1.0	0.0	+1.0	-1.2	0.0	+1.2	ns
t <sub>PWH</sub>	Output HIGH Time Deviation from 50% <sup>[23, 24]</sup>				2.5			4.0	ns
t <sub>PWL</sub>	Output LOW Time Deviation from 50% <sup>[23, 24]</sup>				3			4.0	ns
t <sub>ORISE</sub>	Output Rise Time <sup>[23, 25]</sup>		0.15	1.0	1.5	0.5	2.0	3.5	ns
t <sub>OFALL</sub>	Output Fall Time <sup>[23, 25]</sup>		0.15	1.0	1.5	0.5	2.0	3.5	ns
t <sub>LOCK</sub>	PLL Lock Time <sup>[26]</sup>				0.5			0.5	ms
t <sub>JR</sub>	Cycle-to-Cycle Output Jitter	RMS <sup>[14]</sup>			25			25	ps
		Peak-to-Peak <sup>[14]</sup>			200			200	ps

## Switching Characteristics

Over the Operating Range<sup>[2, 13]</sup> (continued)

Parameter	Description		CY7B991-7			CY7B992-7			Unit
			Min	Typ	Max	Min	Typ	Max	
f <sub>NOM</sub>	Operating Clock Frequency in MHz	FS = LOW <sup>[1, 2]</sup>	15		30	15		30	MHz
		FS = MID <sup>[1, 2]</sup>	25		50	25		50	
		FS = HIGH <sup>[1, 2]</sup>	40		80	40		80 <sup>[15]</sup>	
t <sub>RPWH</sub>	REF Pulse Width HIGH		5.0			5.0			ns
t <sub>RPWL</sub>	REF Pulse Width LOW		5.0			5.0			ns
t <sub>J</sub>	Programmable Skew Unit		See Table 2						
t <sub>SKEWPR</sub>	Zero Output Matched-Pair Skew (XQ0, XQ1) <sup>[16, 17]</sup>			0.1	0.25		0.1	0.25	ns
t <sub>SKEW0</sub>	Zero Output Skew (All Outputs) <sup>[16, 18]</sup>			0.3	0.75		0.3	0.75	ns
t <sub>SKEW1</sub>	Output Skew (Rise-Rise, Fall-Fall, Same Class Outputs) <sup>[16, 19]</sup>			0.6	1.0		0.6	1.0	ns
t <sub>SKEW2</sub>	Output Skew (Rise-Fall, Nominal-Inverted, Divided-Divided) <sup>[16, 19]</sup>			1.0	1.5		1.0	1.5	ns
t <sub>SKEW3</sub>	Output Skew (Rise-Rise, Fall-Fall, Different Class Outputs) <sup>[16, 19]</sup>			0.7	1.2		0.7	1.2	ns
t <sub>SKEW4</sub>	Output Skew (Rise-Fall, Nominal-Divided, Divided-Inverted) <sup>[16, 19]</sup>			1.2	1.7		1.2	1.7	ns
t <sub>DEV</sub>	Device-to-Device Skew <sup>[14, 22]</sup>				1.65			1.65	ns
t <sub>PD</sub>	Propagation Delay, REF Rise to FB Rise		-0.7	0.0	+0.7	-0.7	0.0	+0.7	ns
t <sub>ODCV</sub>	Output Duty Cycle Variation <sup>[22]</sup>		-1.2	0.0	+1.2	-1.5	0.0	+1.5	ns
t <sub>PWH</sub>	Output HIGH Time Deviation from 50% <sup>[23, 24]</sup>				3			5.5	ns
t <sub>PWL</sub>	Output LOW Time Deviation from 50% <sup>[23, 24]</sup>				3.5			5.5	ns
t <sub>ORISE</sub>	Output Rise Time <sup>[23, 25]</sup>		0.15	1.5	2.5	0.5	3.0	5.0	ns
t <sub>OFALL</sub>	Output Fall Time <sup>[23, 25]</sup>		0.15	1.5	2.5	0.5	3.0	5.0	ns
t <sub>LOCK</sub>	PLL Lock Time <sup>[26]</sup>				0.5			0.5	ms
t <sub>JR</sub>	Cycle-to-Cycle Output Jitter	RMS <sup>[14]</sup>			25			25	ps
		Peak-to-Peak <sup>[14]</sup>			200			200	ps

## AC Timing Diagrams

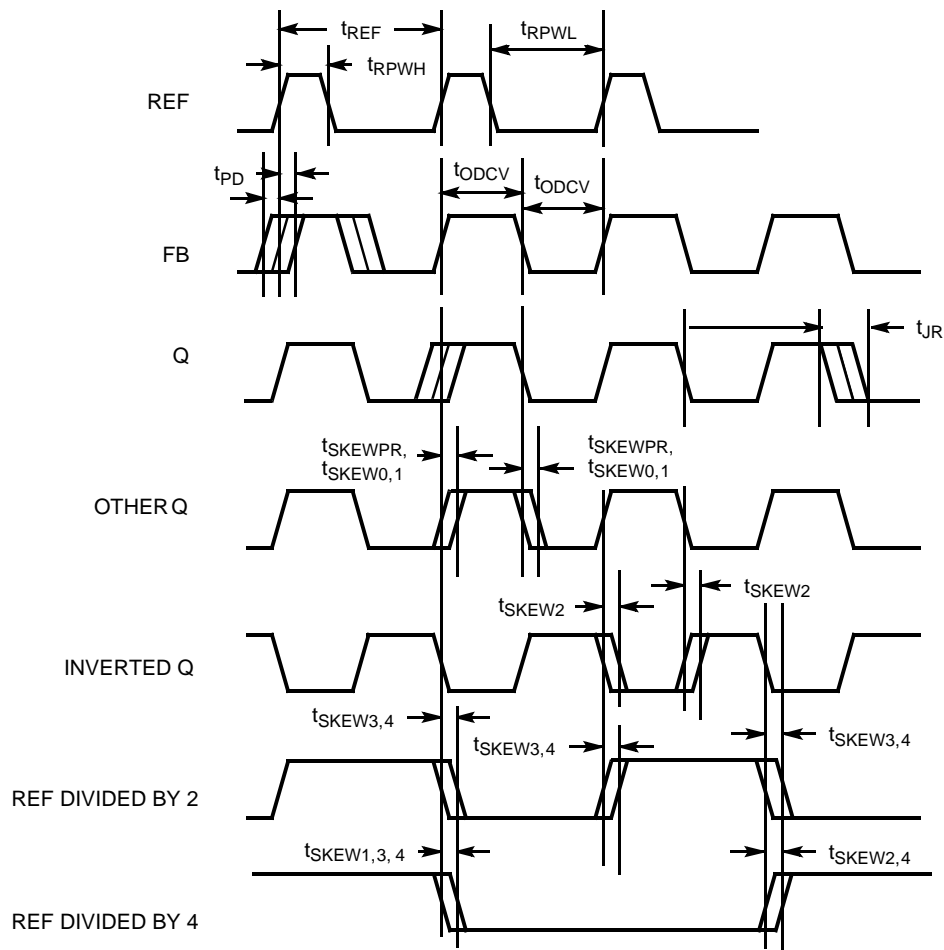

## Operational Mode Descriptions

Figure 4. Zero Skew and Zero Delay Clock Driver

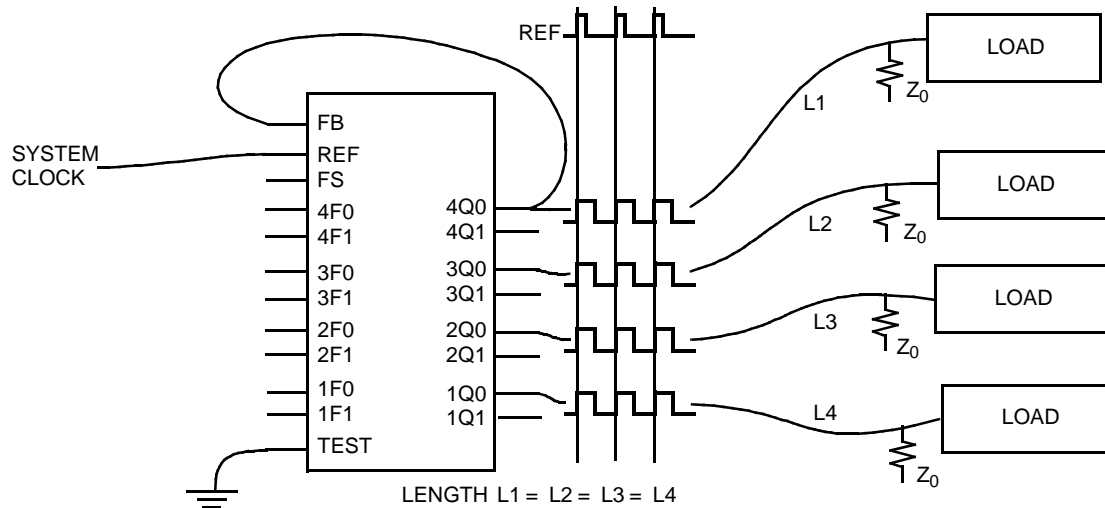

Figure 4 shows the PSCB configured as a zero skew clock buffer. In this mode the 7B991/992 is used as the basis for a low-skew clock distribution tree. When all of the function select inputs (xF0, xF1) are left open, the outputs are aligned and each drives a terminated transmission line to an independent load. The FB input is tied to any output in this configuration and the operating frequency range is selected with the FS pin. The low-skew specification, coupled with the ability to drive terminated transmission lines (with impedances as low as 50 ohms), enables efficient printed circuit board design.

Figure 5. Programmable Skew Clock Driver

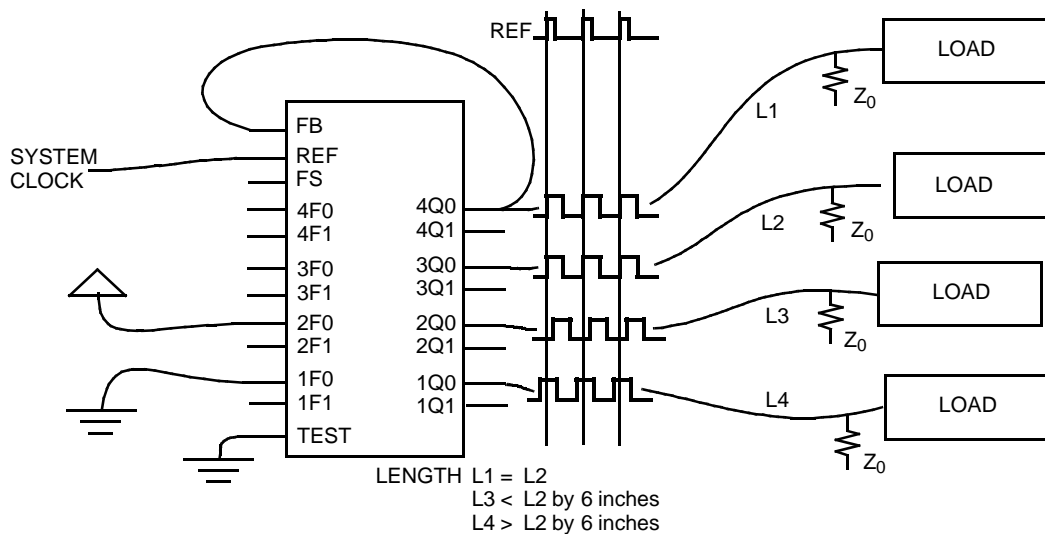

Figure 5 shows a configuration to equalize skew between metal traces of different lengths. In addition to low skew between outputs, the PSCB is programmed to stagger the timing of its outputs. Each of the four groups of output pairs are programmed to different output timing. Skew timing is adjusted over a wide range in small increments with the appropriate strapping of the function select pins. In this configuration the 4Q0 output is fed

back to FB and configured for zero skew. The other three pairs of outputs are programmed to yield different skews relative to the feedback. By advancing the clock signal on the longer traces or retarding the clock signal on shorter traces, all loads can receive the clock pulse at the same time.

In this illustration the FB input is connected to an output with 0-ns skew (xF1, xF0 = MID) selected. The internal PLL synchronizes

the FB and REF inputs and aligns their rising edges to ensure that all outputs have precise phase alignment.

Clock skews are advanced by  $\pm 6$  time units (tU) when using an output selected for zero skew as the feedback. A wider range of delays is possible if the output connected to FB is also skewed. Since "Zero Skew", +tU, and -tU are defined relative to output groups, and since the PLL aligns the rising edges of REF and FB, you can create wider output skews by proper selection of the xFn inputs. For example, a +10 tU between REF and 3Qx is achieved by connecting 1Q0 to FB and setting 1F0 = 1F1 = GND, 3F0 = MID, and 3F1 = High. (Since FB aligns at -4 tU and 3Qx skews to +6 tU, a total of +10 tU skew is realized.) Many other configurations are realized by skewing both the outputs used as the FB input and skewing the other outputs.

Figure 6. Inverted Output Connections

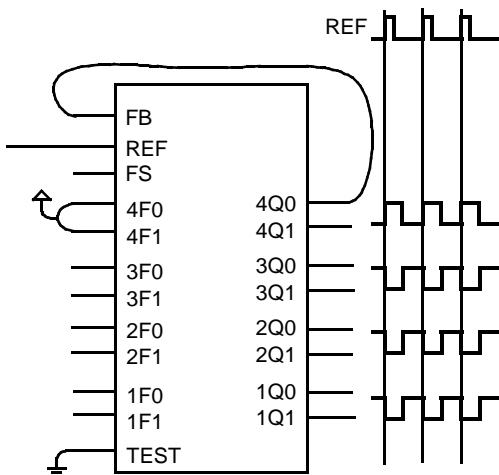

Figure 6 shows an example of the invert function of the PSCB. In this example the 4Q0 output used as the FB input is programmed for invert (4F0 = 4F1 = HIGH) while the other three pairs of outputs are programmed for zero skew. When 4F0 and 4F1 are tied high, 4Q0 and 4Q1 become inverted zero phase outputs. The PLL aligns the rising edge of the FB input with the rising edge of the REF. This causes the 1Q, 2Q, and 3Q outputs to become the "inverted" outputs with respect to the REF input. It is possible to have 2 inverted and 6 non-inverted outputs or 6 inverted and 2 non-inverted outputs by selecting the output connected to FB. The correct configuration is determined by the need for more (or fewer) inverted outputs. 1Q, 2Q, and 3Q outputs can also be skewed to compensate for varying trace delays independent of inversion on 4Q.

Figure 7. Frequency Multiplier with Skew Connections

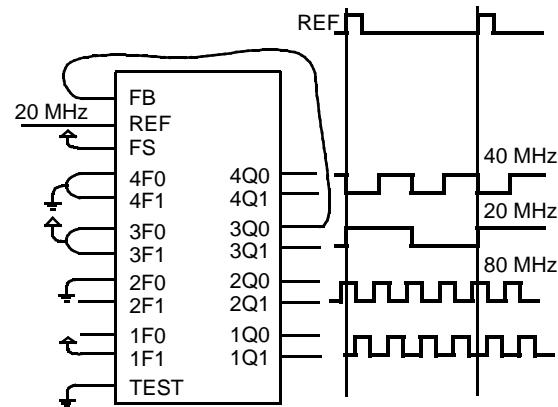

Figure 7 shows the PSCB configured as a clock multiplier. The 3Q0 output is programmed to divide by four and is sent to FB. This causes the PLL to increase its frequency until the 3Q0 and 3Q1 outputs are locked at 20 MHz while the 1Qx and 2Qx outputs run at 80 MHz. The 4Q0 and 4Q1 outputs are programmed to divide by two, that results in a 40 MHz waveform at these outputs. Note that the 20 and 40 MHz clocks fall simultaneously and are out of phase on their rising edge. This enables the designer to use the rising edges of the  $\frac{1}{2}$  frequency and  $\frac{1}{4}$  frequency outputs without concern for rising edge skew. The 2Q0, 2Q1, 1Q0, and 1Q1 outputs run at 80 MHz and are skewed by programming their select inputs accordingly. Note that the FS pin is wired for 80 MHz operation because that is the frequency of the fastest output.

Figure 8. Frequency Divider Connections

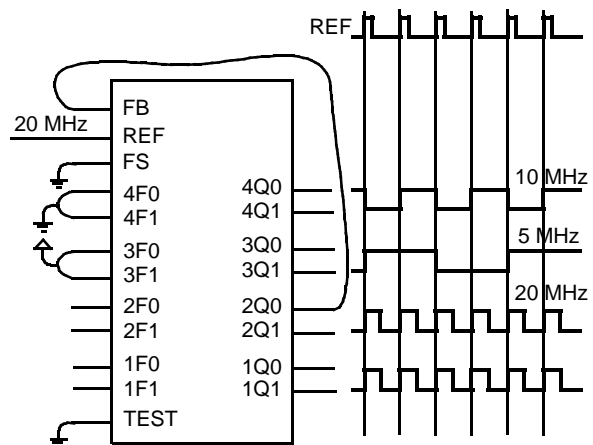

Figure 8 demonstrates the PSCB in a clock divider application. 2Q0 is fed back to the FB input and programmed for zero skew. 3Qx is programmed to divide by four. 4Qx is programmed to divide by two. Note that the falling edges of the 4Qx and 3Qx outputs are aligned. This enables the use of rising edges of the  $\frac{1}{2}$  frequency and  $\frac{1}{4}$  frequency without concern for skew mismatch. The 1Qx outputs are programmed to zero skew and are aligned with the 2Qx outputs. In this example, the FS input is grounded to configure the device in the 15 MHz to 30 MHz

range since the highest frequency output is running at 20 MHz. Figure 9 shows some of the functions that are selectable on the 3Qx and 4Qx outputs. These include inverted outputs and outputs that offer divide-by-2 and divide-by-4 timing. An inverted output enables the system designer to clock different subsystems on opposite edges, without suffering from the pulse asymmetry typical of non-ideal loading. This function enables each of the two subsystems to clock 180 degrees out of phase and align within the skew specifications.

The divided outputs offer a zero delay divider for portions of the system that need the clock divided by either two or four, and still remain within a narrow skew of the "1X" clock. Without this feature, an external divider is added, and the propagation delay

of the divider adds to the skew between the different clock signals.

These divided outputs, coupled with the Phase Locked Loop, enables the PSCB to multiply the clock rate at the REF input by either two or four. This mode enables the designer to distribute a low frequency clock between various portions of the system, and then locally multiply the clock rate to a more suitable frequency, still maintaining the low skew characteristics of the clock driver. The PSCB performs all of the functions described in this section at the same time. It multiplies by two and four or divides by two (and four) at the same time. In other words, it is shifting its outputs over a wide range or maintaining zero skew between selected outputs.

Figure 9. Multi-Function Clock Driver

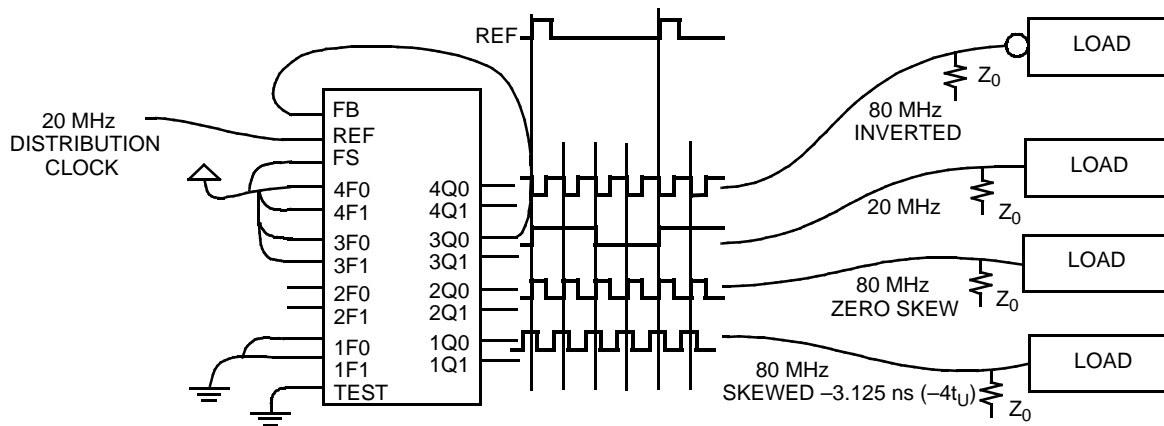

Figure 10. Board-to-Board Clock Distribution

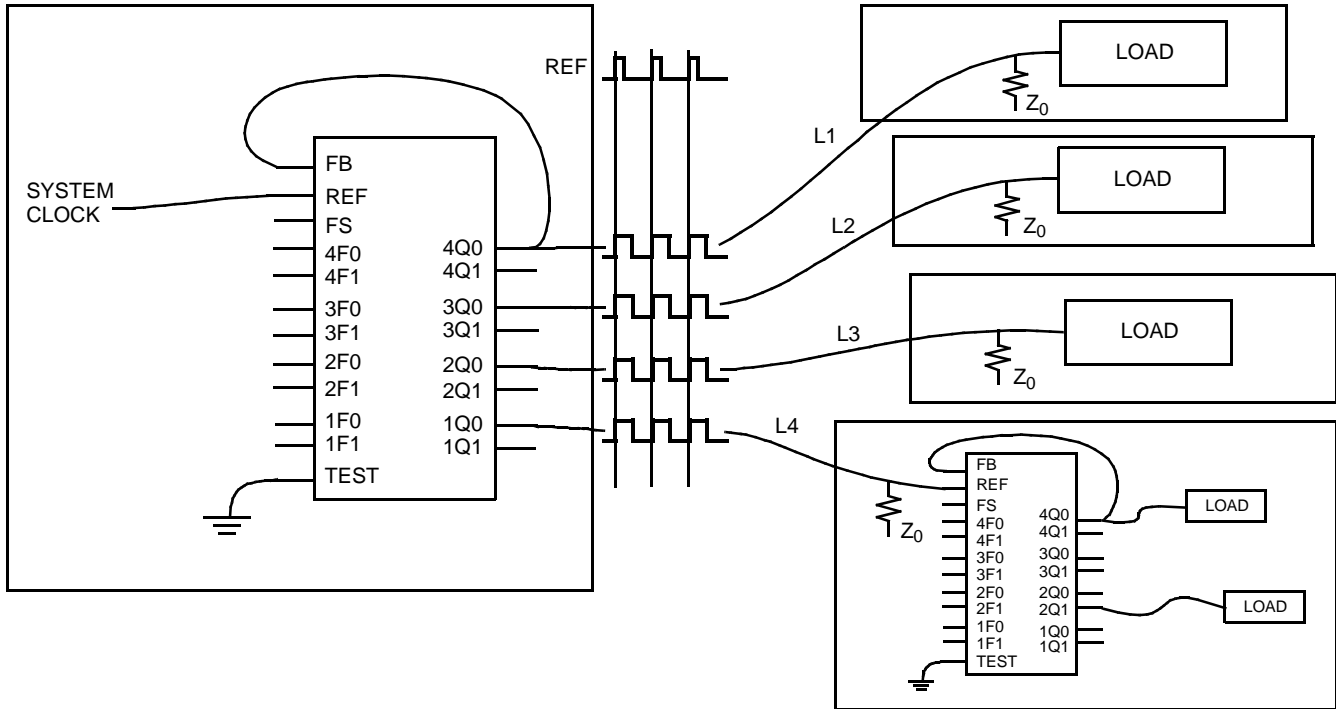

Figure 10 shows the CY7B991 and 992 connected in series to construct a zero skew clock distribution tree between boards. Delays of the downstream clock buffers are programmed to compensate for the wire length (that is, select negative skew equal to the wire delay) necessary to connect them to the master clock source, approximating a zero delay clock tree. Cascaded clock buffers accumulates low frequency jitter because of the non-ideal filtering characteristics of the PLL filter. Do not connect more than two clock buffers in series.

## Ordering Information

Accuracy (ps)	Ordering Code	Package Type	Operating Range
250	CY7B991-2JC	32-Pin Plastic Leaded Chip Carrier	Commercial
	CY7B991-2JCT	32-Pin Plastic Leaded Chip Carrier - Tape and Reel	Commercial
500	CY7B991-5JC	32-Pin Plastic Leaded Chip Carrier	Commercial
	CY7B991-5JCT	32-Pin Plastic Leaded Chip Carrier - Tape and Reel	Commercial
	CY7B991-5JI	32-Pin Plastic Leaded Chip Carrier	Industrial
	CY7B991-5JIT	32-Pin Plastic Leaded Chip Carrier - Tape and Reel	Industrial
750	CY7B991-7JC	32-Pin Plastic Leaded Chip Carrier	Commercial
	CY7B991-7JCT	32-Pin Plastic Leaded Chip Carrier - Tape and Reel	Commercial
	CY7B991-7JI	32-Pin Plastic Leaded Chip Carrier	Industrial
	CY7B991-7LMB <sup>[27]</sup>	32-Pin Rectangular Leadless Chip Carrier	Military
250	CY7B992-2JC	32-Pin Plastic Leaded Chip Carrier	Commercial
	CY7B992-2JCT	32-Pin Plastic Leaded Chip Carrier - Tape and Reel	Commercial
500	CY7B992-5JC	32-Pin Plastic Leaded Chip Carrier	Commercial
	CY7B992-5JCT	32-Pin Plastic Leaded Chip Carrier - Tape and Reel	Commercial
	CY7B992-5JI <sup>[27]</sup>	32-Pin Plastic Leaded Chip Carrier	Industrial
	CY7B992-5JIT	32-Pin Plastic Leaded Chip Carrier - Tape and Reel	Industrial
750	CY7B992-7JC	32-Pin Plastic Leaded Chip Carrier	Commercial
	CY7B992-7JCT	32-Pin Plastic Leaded Chip Carrier - Tape and Reel	Commercial
	CY7B992-7JI	32-Pin Plastic Leaded Chip Carrier	Industrial
	CY7B992-7LMB <sup>[27]</sup>	32-Pin Rectangular Leadless Chip Carrier	Military
<b>Pb-Free</b>			
250	CY7B991-2JXC	32-Pin Plastic Leaded Chip Carrier	Commercial
	CY7B991-2JXCT	32-Pin Plastic Leaded Chip Carrier - Tape and Reel	Commercial
500	CY7B991-5JXC	32-Pin Plastic Leaded Chip Carrier	Commercial
	CY7B991-5JXCT	32-Pin Plastic Leaded Chip Carrier - Tape and Reel	Commercial
	CY7B991-5JXI	32-Pin Plastic Leaded Chip Carrier	Industrial
	CY7B991-5JXIT	32-Pin Plastic Leaded Chip Carrier - Tape and Reel	Industrial
750	CY7B991-7JXC	32-Pin Plastic Leaded Chip Carrier	Commercial
	CY7B991-7JXCT	32-Pin Plastic Leaded Chip Carrier - Tape and Reel	Commercial
500	CY7B992-5JXI	32-Pin Plastic Leaded Chip Carrier	Industrial
	CY7B992-5JXIT	32-Pin Plastic Leaded Chip Carrier - Tape and Reel	Industrial

**Note**

27. Not recommended for the new design.

## Military Specifications

### Group A Subgroup Testing

### DC Characteristics

Parameter	Subgroups
V <sub>OH</sub>	1, 2, 3
V <sub>OL</sub>	1, 2, 3
V <sub>IH</sub>	1, 2, 3
V <sub>IL</sub>	1, 2, 3
V <sub>IHH</sub>	1, 2, 3
V <sub>IMM</sub>	1, 2, 3
V <sub>ILL</sub>	1, 2, 3
I <sub>IH</sub>	1, 2, 3
I <sub>IL</sub>	1, 2, 3
I <sub>IHH</sub>	1, 2, 3
I <sub>IMM</sub>	1, 2, 3
I <sub>ILL</sub>	1, 2, 3
I <sub>CCQ</sub>	1, 2, 3
I <sub>CCN</sub>	1, 2, 3

### Package Diagrams

Figure 11. 32-Pin Plastic Leaded Chip Carrier

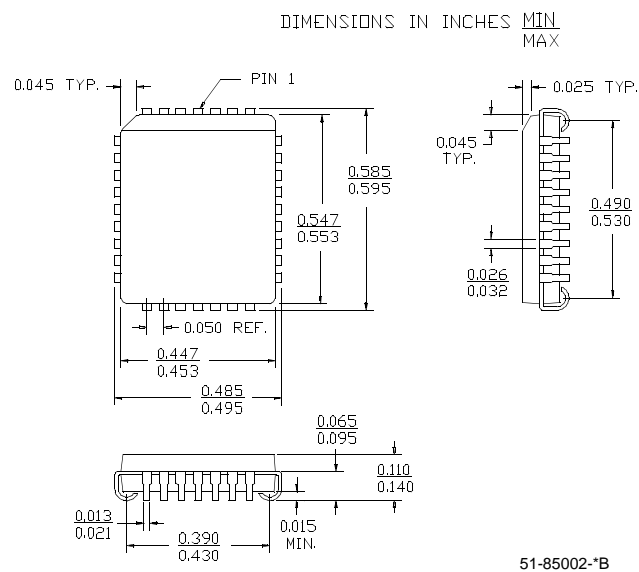

Package Diagrams (continued)

Figure 12. 32-Pin Rectangular Leadless Chip Carrier

MIL-STD-1835 C-12

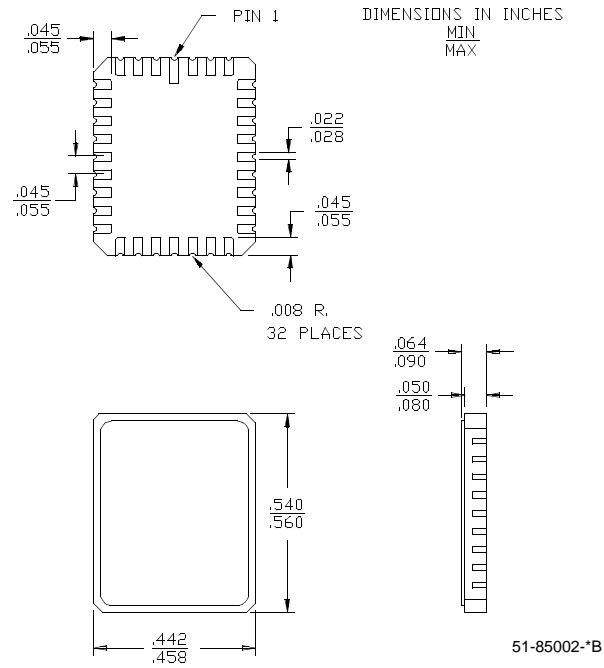

## Document History Page

Document Title: CY7B991/CY7B992 Programmable Skew Clock Buffer Document Number: 38-07138				
Revision	ECN	Orig. of Change	Submission Date	Description of Change
**	110247	SZV	12/19/01	Change from Specification number: 38-00513 to 38-07138
*A	1199925	KVM/AESA	See ECN	Add Pb-free part numbers. Update package names in Ordering Information table. Remove Pentium reference on page 1.
*B	1286064	AESA	See ECN	Change status to final
*C	2750166	TSAI	08/10/09	Post to external web
*D	2761988	CXQ	09/10/09	Fixed Ordering Information table replacement error of "lead" with "Pb".

## Sales, Solutions, and Legal Information

### Worldwide Sales and Design Support

Cypress maintains a worldwide network of offices, solution centers, manufacturer's representatives, and distributors. To find the office closest to you, visit us at [cypress.com/sales](http://cypress.com/sales)

### Products

PSoC	<a href="http://psoc.cypress.com">psoc.cypress.com</a>
Clocks & Buffers	<a href="http://clocks.cypress.com">clocks.cypress.com</a>
Wireless	<a href="http://wireless.cypress.com">wireless.cypress.com</a>
Memories	<a href="http://memory.cypress.com">memory.cypress.com</a>
Image Sensors	<a href="http://image.cypress.com">image.cypress.com</a>

© Cypress Semiconductor Corporation, 2001-2009. The information contained herein is subject to change without notice. Cypress Semiconductor Corporation assumes no responsibility for the use of any circuitry other than circuitry embodied in a Cypress product. Nor does it convey or imply any license under patent or other rights. Cypress products are not warranted nor intended to be used for medical, life support, life saving, critical control or safety applications, unless pursuant to an express written agreement with Cypress. Furthermore, Cypress does not authorize its products for use as critical components in life-support systems where a malfunction or failure may reasonably be expected to result in significant injury to the user. The inclusion of Cypress products in life-support systems application implies that the manufacturer assumes all risk of such use and in doing so indemnifies Cypress against all charges.

Any Source Code (software and/or firmware) is owned by Cypress Semiconductor Corporation (Cypress) and is protected by and subject to worldwide patent protection (United States and foreign), United States copyright laws and international treaty provisions. Cypress hereby grants to licensee a personal, non-exclusive, non-transferable license to copy, use, modify, create derivative works of, and compile the Cypress Source Code and derivative works for the sole purpose of creating custom software and or firmware in support of licensee product to be used only in conjunction with a Cypress integrated circuit as specified in the applicable agreement. Any reproduction, modification, translation, compilation, or representation of this Source Code except as specified above is prohibited without the express written permission of Cypress.

Disclaimer: CYPRESS MAKES NO WARRANTY OF ANY KIND, EXPRESS OR IMPLIED, WITH REGARD TO THIS MATERIAL, INCLUDING, BUT NOT LIMITED TO, THE IMPLIED WARRANTIES OF MERCHANTABILITY AND FITNESS FOR A PARTICULAR PURPOSE. Cypress reserves the right to make changes without further notice to the materials described herein. Cypress does not assume any liability arising out of the application or use of any product or circuit described herein. Cypress does not authorize its products for use as critical components in life-support systems where a malfunction or failure may reasonably be expected to result in significant injury to the user. The inclusion of Cypress' product in a life-support systems application implies that the manufacturer assumes all risk of such use and in doing so indemnifies Cypress against all charges.

Use may be limited by and subject to the applicable Cypress software license agreement.