

Feb. 1985

Features

- Provides DTMF high and low group filtering
- Hard-limiting on filter outputs
- 6 pole bandpass high and low group filters
- 40 dB (typ) Intergroup attenuation
- Dial tone suppression
- +5 to +12V single supply operation
- Logical powerdown
- Uses inexpensive 3.58 MHz crystal
- Wide dynamic range 30dB

Applications

In DTMF Receivers For

- End-to-end signalling
- Control systems
- PABX
- Central Office
- Mobile Radio
- Key systems
- Tone to pulse converters

Description

The Mitel MT8865 contains both the high group and low group filtering and comparator functions required to implement a Dual Tone Multi Frequency tone receiver using a Mitel DTMF Digital Detector (i.e., Mitel MT8860). Switched capacitor techniques are used to implement the filters and the device is fabricated using Mitel's double poly ISO²-CMOS high density technology. The filter clocks are

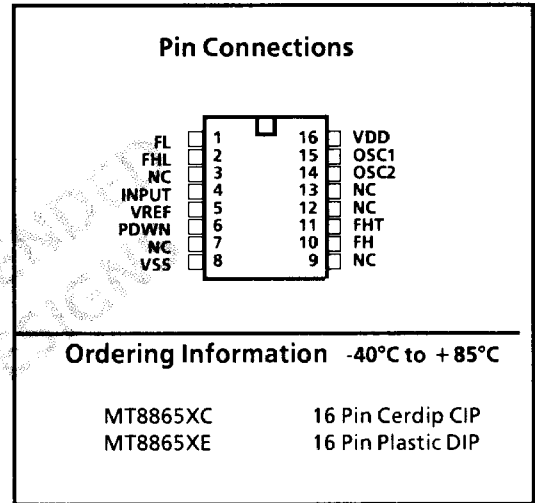

derived from an on-chip oscillator requiring only a low cost TV crystal as external components. The MT8865 offers single supply operation over a wide supply voltage range and incorporates a logical power down facility.

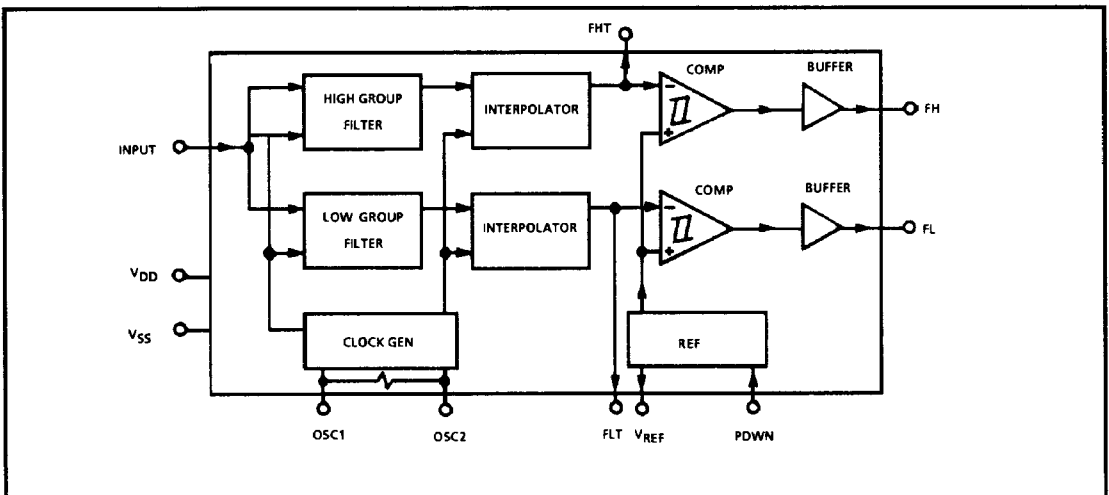

Fig. 1 Functional Block Diagram

Absolute Maximum Ratings*

	Parameter	Symbol	Min	Max	Units	
1	$V_{DD} - V_{SS}$			15	V	
2	Voltage on any pin except OS1, OSC2		$V_{EE} - 0.3$	$V_{DD} + 0.3$	V	
3	Max. Current at any pin	I_I		10	mA	
4	Storage Temperature	C Package	T_{STG}	-65	+150	°C
		E Package	T_{STG}	-65	+125	°C
5	Power Dissipation	C Package ^①	P_D		850	mW
		E Package ^②	P_D		400	mW

* Exceeding these values may cause permanent damage. Functional operation under these conditions is not implied.

^① Derate above 75°C at 16 mW / °C. All leads soldered to board.

^② Derate above 25°C at 6.3 mW / °C. All leads soldered to board.

Recommended Operating Conditions - Voltages are with respect to ground (V_{SS}) unless otherwise stated.

	Parameter	Sym	Min	Typ [†]	Max	Units	Test Conditions
1	DC Power Supply Voltage	V_{DD}	4.75		13	V	
2	Operating Temperature	T_O	-40		+85	°C	

[†] Typical figures are at 25°C and are for design aid only: not guaranteed and not subject to production testing.

DC Electrical Characteristics - Voltages are with respect to ground (V_{SS}), $T_A = 25^\circ\text{C}$, $f_c = 3.579545$ MHz unless otherwise stated.

	Characteristics	Sym	Min	Typ [†]	Max	Units	Test Conditions
1	Operating Supply Voltage	V_{DD}	4.75		13	V	$V_{DD} = 5V$
		V_{DD}				V	$V_{DD} = 12V$
2	Operating Supply Current	I_{DD}		1.2	3	mA	$V_{DD} = 5V, PDWN = V_{SS}$
		I_{DD}		5	10	mA	$V_{DD} = 12V, PDWN = V_{SS}$
3	Standby Supply Current	I_{DDs}		70	100	µA	$V_{DD} = 5V, PDWN = V_{DD}$
		I_{DDs}		300	500	µA	$V_{DD} = 12V, PDWN = V_{DD}$
4	Operating Power Consumption Fig. 5(c)	P_O		6		mW	$V_{DD} = 5V, PDWN = V_{SS}$
		P_O		60		mW	$V_{DD} = 12V, PDWN = V_{SS}$
5	Standby Power Consumption $C = 15$ pF	P_S		0.5		mW	$V_{DD} = 5V, PDWN = V_{DD}$
		P_S		1.5		mW	$V_{DD} = 12V, PDWN = V_{DD}$
6	Low Level Input Voltage PDWN & OSC1	V_{IL}			1.5	V	$V_{DD} = 5V$
		V_{IL}			3.5	V	$V_{DD} = 12V$
7	High Level Input Voltage PDWN & OSC1	V_{IH}	3.5			V	$V_{DD} = 5V$
		V_{IH}	8.5			V	$V_{DD} = 12V$
8	Pull Down Sink Current PDWN	I_{IH}		3	6	µA	$V_{DD} = 5V$
		I_{IH}		12	24	µA	$V_{DD} = 12V$
9	Input Current OSC1	I_I		± 2.5		µA	$V_{DD} = 5V$
		I_I		± 6		µA	$V_{DD} = 12V$
10	Low Level Output Voltage FL, FH, OSC2	V_{OL}			0.1	V	$V_{DD} = 5V, \text{No Load}$
		V_{OL}			0.1	V	$V_{DD} = 12V, \text{No Load}$
11	High Level Output Voltage FL, FH, OSC2	V_{OH}	4.9			V	$V_{DD} = 5V, \text{No Load}$
		V_{OH}	11.9			V	$V_{DD} = 12V, \text{No Load}$
12	Output Drive Current, FL, FH N Channel Sink	I_{OL}	0.2			mA	$V_{DD} = 5V, V_{OL} = 0.4V$
		I_{OL}	0.5			mA	$V_{DD} = 12V, V_{OL} = 1.2V$

[†] Typical figures are at 25°C and are for design aid only: not guaranteed and not subject to production testing

DC Electrical Characteristics (Cont'd) - Voltages are with respect to ground (V_{SS}), $T_A = 25^\circ\text{C}$, $f_c = 3.579545$ MHz unless otherwise stated.

		Characteristics	Sym	Min	Typ [†]	Max	Units	Test Conditions
13	O U T P U T S	Output Drive Current OSC2, N Channel Sink	I_{OL} I_{OL}	0.1 0.25			mA mA	$V_{DD} = 5V, V_{OL} = .4V$ $V_{DD} = 12V, V_{OL} = 1.2V$
14		Output Drive Current, FL, FH P Channel Source	I_{OH} I_{OH}	0.2 0.5			mA mA	$V_{DD} = 5V, V_{OH} = 4.6V$ $V_{DD} = 12V, V_{OH} = 10.8V$
15		Output Drive Current, OSC2, P Channel Source	I_{OH} I_{OH}	0.1 0.25			mA mA	$V_{DD} = 5V, V_{OH} = 4.6V$ $V_{DD} = 12V, V_{OH} = 10.8V$
16		Output Voltage, V_{Ref}	V_{Ref} V_{Ref}	2.3 5.4		2.6 6.2	V V	$V_{DD} = 5V, \text{No Load}$ $V_{DD} = 12V, \text{No Load}$
17		Output Resistance, V_{Ref}	R_{OR} R_{OR}				16 8	k Ω k Ω

[†] Typical figures are at 25°C and are for design aid only: not guaranteed and not subject to production testing.

AC Electrical Characteristics - Voltages are with respect to ground (V_{SS}), $T_A = 25^\circ\text{C}$, $f_c = 3.579545$, $V_{DD} = 4.75 - 13V$.

		Characteristics	Sym	Min	Typ [†]	Max	Units	Test Conditions	
1	F I L T E R	Dynamic Range		30		36	dB		
2		Valid Input Signal Levels (Each tone of composite signal)		27.9 67.0		$V_{DD}/2$ 883 2120	V_{pp} mVrms mVrms	$V_{DD} = 5V$ $V_{DD} = 12V$	
3		Input Impedance	Z_I	10			M Ω		
4		Passband Ripple	A_V		± 0.3	± 1.0	dB	See Note 1	
5		Low Group 1dB Bandwidth	Lower Limit Upper Limit	f_{LL} f_{LU}	958	670 990	684	Hz Hz	
6		High Group 1dB Bandwidth	Lower Limit Upper Limit	f_{HL} f_{HU}	1660	1162 1740	1188	Hz Hz	
7		Intergroup Rejection Low Group with High Tone	IR_{L1209} IR_{L1477}	34 36	45 40		dB dB	1209Hz - w.r.t. 770Hz 1477Hz - w.r.t. 770Hz	
8		Intergroup Rejection High Group with Low Tone	IR_{H941} IR_{H770}	38 36	50 40		dB dB	941Hz - w.r.t. 1336Hz 770Hz - w.r.t. 1336Hz	
9		Dial Tone Rejection Low Group	DR_{L440} DR_{L350}	40 28	60 30		dB dB	440Hz - w.r.t. 770Hz 440Hz - w.r.t. 770Hz	
10		Dial Tone Rejection High Group	DR_{H440} DR_{H350}	52 50	60 55		dB dB	440Hz - w.r.t. 1336Hz 350Hz - w.r.t. 1336Hz	
11		FHT FLT Maximum Permissible Load	R_{LFT} C_{LFT}	250			1000	k Ω pF	
12		Output Rise Time Output Fall Time	FL, FH FL, FH	t_{TLHO} t_{THLO}		90 60	150 100	ns ns	10% to 90% V_{DD}
13		Crystal/Clock Freq. OSC1, OSC 2		f_c	3.5759	3.5795	3.5831	MHz	
14		Clock Input (OSC 1)	Rise Time Fall Time Duty Cycle	t_{LHCI} t_{HLCI} DC_{CI}	40	50	110 110 60	ns ns %	See Note 2
15		Clock Output OSC 2 Capacitive Load		C_{LOC}			30	pF	Unbalanced load see Fig. 5
16		Capacitance Any Input		C_I		5	7.5	pF	

Note 1. Passband ripple measured with respect to a passband gain of 0 dB \pm 1dB.

Note 2. 10% to 90% V_{DD} . Externally Applied Clock.

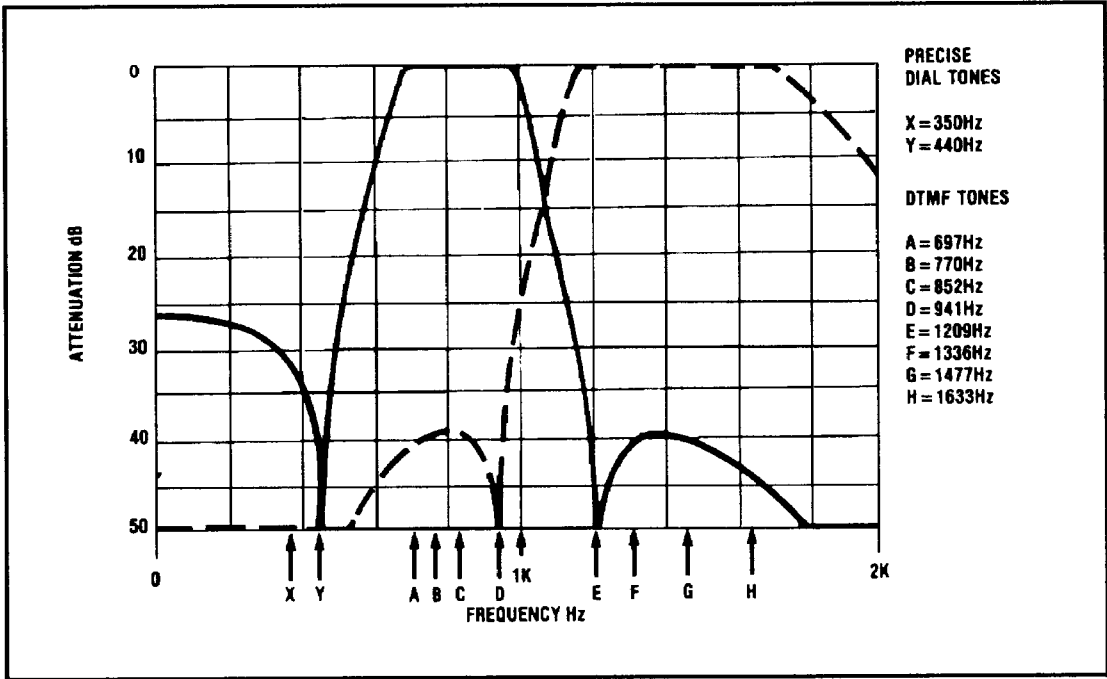

Fig. 2 - Typical Filter Characteristics

Pin Description

Pin #	Name	Description
1	FL	Low Group Limiter Output.
2	FLT	Test Output. Monitors low group filter output. Decouple to V _{SS} with 680pF capacitor.
3	NC	Not Connected.
4	INPUT	Tone Signal Input (single ended).
5	V _{Ref}	Internal Reference. Can be used to bias input via 2MΩ resistor.
6	PDWN	Power Down Active High. Internal pull down transistor. A high level signal powers down the device and inhibits the oscillator.
7	NC	Not Connected.
8	V _{SS}	Negative (0V) Power Supply.
9	NC	Not Connected.
10	FH	High Group Limiter Output.
11	FHT	Test Output. Monitors high group filter output. Decouple to V _{SS} with 680pF capacitor.
12	NC	Not Connected.
13	NC	Not Connected.
14	OSC2	Clock Output.
15	OSC1	Clock Input. 3.579545 MHz crystal connected between this pin and OS2 completes the internal oscillator circuit.
16	VDD	Positive Power Supply.

Functional Description

The MT8865 separates the high group and low group components of the dual tone signal and limits the resulting pair of sine waves, to produce square waves having the same frequencies as the individual input tones. These limited low group and high group tones appear at the FL and FH outputs respectively. To implement a complete DTMF receiver the FL and FH outputs are connected to the FL and FH inputs of the DTMF Digital Decoder (MT8860). See Fig. 3.

Separation of the low group and high group tones is achieved by applying the dual tone signal simultaneously to the inputs of two sixth order switched capacitor bandpass filters, the bandwidths

of which correspond to the bands enclosing the low group and high group tones. The frequency characteristic of each filter (see Fig. 2) also incorporates a notch at 440Hz to provide dial tone rejection. Each filter output is followed by a single order switched capacitor section which operates as an interpolator smoothing the signals prior to limiting. The limiting functions are performed by high gain comparators which are provided with hysteresis to prevent detection of unwanted low level signals and noise. The comparator outputs are buffered to drive the FL and FH output pins and detector device inputs. The MT8865 has a single ended input allowing connection either to a PCM decoder, radio receiver (Fig. 3) or via a differential buffer to a telephone line (Fig. 4). The signal input (Pin 4) should be biased at $V_{DD}/2$. With the input

3

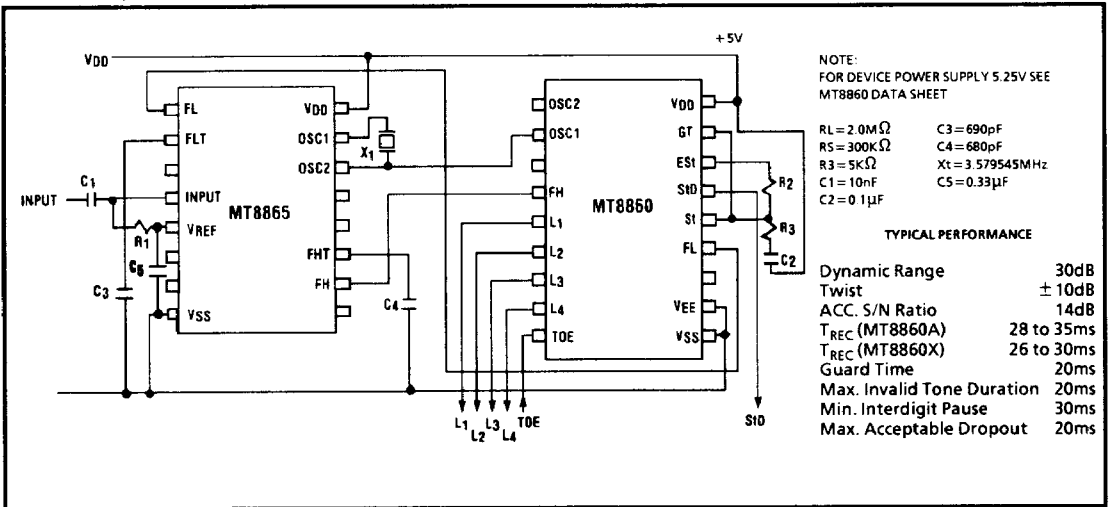

Fig. 3 - Connection Diagram for Single-Ended Input Receiver Using the MT8860 (5V Operation)

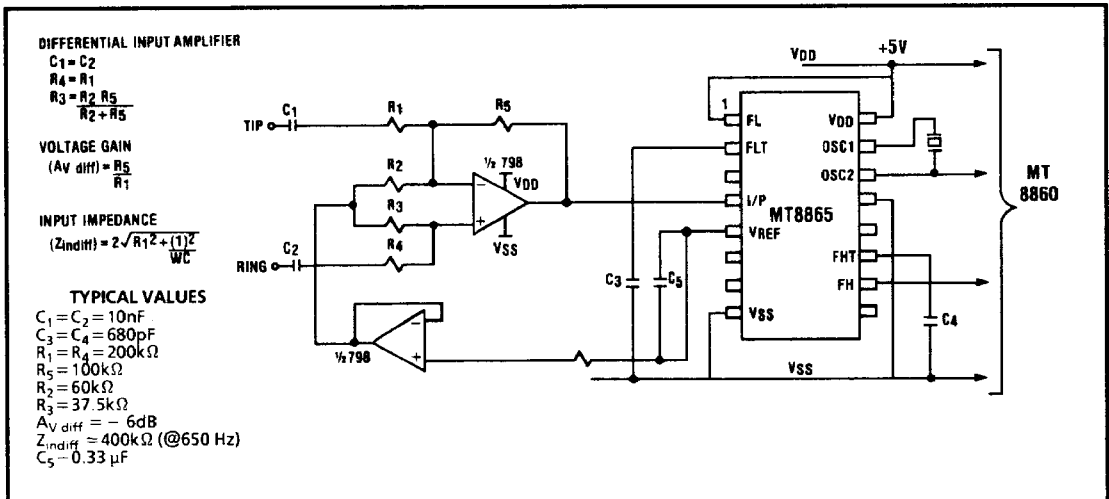

Fig. 4 - Circuit for Connection to a Telephone Line

